



CATÁLOGO GENERAL
GENERAL CATALOGUE

Bombas Centrífugas y Normalizadas DIN 24.255 <i>Centrifugal Pumps and Standardized DIN 24.255</i>	3
Bombas Centrífugas Verticales Multicelulares <i>Vertical Multistage Pumps</i>	31
Bombas Centrífugas Autoaspirantes <i>Self Priming Centrifugal Pumps</i>	41
Bombas Serie Doméstica y Equipos Presión Domésticos <i>Domestic Pumps and Booster Sets</i>	45
Bombas para Piscina y Filtros - Dosificadoras <i>Swimming Pool Pumps and Filters - Dosing Pumps</i>	55
Bombas Sumergibles: Radiales 4" - 6" Semiaxiales 6" - 8" - 10" <i>Submersible Pumps: Radial 4" - 6" Semiaxial 6" - 8" - 10"</i>	75
Bombas Sumergibles Aguas Fecales, Agotamiento y Drenaje <i>Waste Water and Drainage Pumps</i>	97
Bombas para Usos Varios <i>Various Applications Pumps</i>	115
Bombas Circuladoras Calefacción <i>Circulating Pumps Heating and Air Conditioning</i>	123
Accesorios: Prescontrol, Presostatos... <i>Accessories: Prescontrol, Pressure Gauge...</i>	147
Tratamientos de Agua <i>Water Treatment</i>	153
Depósitos Membrana, Galvanizados y Calefacción <i>Water Tanks (Air Vessels, Galvanized and Hot Water)</i>	157
Equipos Presión, Contraincendios y Cuadros Eléctricos <i>Booster Sets, Fire Fighting Units and Control Panels</i>	163
Datos Técnicos <i>Technical Data</i>	195

A

B

C

D

E

F

G

H

I

J

K

L

M

N

Serie "K"	4
Serie "CB"	6
Serie "HK"	7
Series Normalizada "MN"	8
Series Normalizada Monobloc "NKM-G - NKP-G"	11
Series Normalizada Sobre Bancada "KDN"	16
Series "CR" y "CRA"	28
Series "CRB"	29
Series "KONTRA"	30

Tipo Type	Potencia		"A"			Cond. µF	Caudal m ³ /h / Flow m ³ /h										Diámetro	
	HP	KW	II 230	III 230	III 400		1,2	2,4	3,6	4,8	6,0	7,2	8,4	9,6	10,8	ASP.	IMP.	
							Altura m.c.a. / Height w.c.m.											
K 5-M	0,5	0,37	3	-	-	10	22	19	17	14	7					1"	1"	
K 5-T			-	2,3	1,3	-												
K 8-M	1	0,75	6	-	-	20	30	27,5	23	19	16	12				1"	1"	
K 8-T			-	4,3	2,5	-												
K 10-M	1	0,75	5,5	-	-	20	42	41	36	27	14					1"	1"	
K 10-T			-	3,8	2,2	-												
K 15-M	1,5	1,1	7,1	-	-	25	39	38	36	34	32	28	24	18	14	1 1/2"	1"	
K 15-T			-	5,4	3,1	-												
K 17-M	1,5	1,1	8,3	-	-	31,5	52	47	42	34	24					1 1/4"	1"	
K 17-T			-	6	3,5	-												

Tipo Type	Potencia		"A"			Cond. µF	Caudal m ³ /h / Flow m ³ /h										Diámetro		
	HP	KW	II 230	III 230	III 400		1,2	3	4,5	6	7,5	9	10,5	12	18	24	27	ASP.	IMP.
							Altura m.c.a. / Height w.c.m.												
K 20-M	2,5	1,83	9	-	-	40	49	48	45	42	37	30	23					1 1/2"	1"
K 20-T			-	6,2	3,6	-													
K 25-M	2,5	1,83	12,8	-	-	40	60	55	47	35								1 1/4"	1"
K 25-T			-	8,4	4,8	-													
K 30-T	3	2,2	-	11,6	6,7	-	63	60	57	52	45	39						1 1/2"	1"
K 31-T	3	2,2	-	9	5,2	-	37	36	36	35	34	33	32	31	25			2"	1 1/4"
K 40-T	4	3	-	14,6	8,4	-	72	68	65	61	57	52						1 1/2"	1"
K 41-T	4	3	-	11,1	6,4	-	41	41	41	40	39	38	37	35	28			2"	1 1/4"
K 55-T	5,5	4	-	16,5	9,5	-	82	80	78	73	69	61	51					1 1/2"	1"
K 56-T	5,5	4	-	16,3	9,4	-		55	55	54	53	52	52	51	43			2"	1 1/4"
K 75-T*	7,5	5,5	-	-	12,9	-				73	72	71	70	69	58	43		2"	1 1/4"
K 100-T*	10	7,5	-	-	15	-				93	93	91	90	89	79	59		2"	1 1/4"
K 125-T*	12,5	9,2	-	-	18	-						84	83	82	74	65	55	2"	1 1/4"
K 150-T*	15	11	-	-	21	-						95	95	95	88	77	70	2"	1 1/4"

* Voltaje habitual 400/690. (Bajo demanda 230/400).

* Standard voltage 400/690. (Under demand 230/400).



■ Aplicaciones:

Bombas centrífugas biturbina, especialmente aptas para su uso en equipos de presión.

Aspiración máxima 7 m.c.a., en caso de aspiraciones superiores a 4 m.c.a., instalar tubo de mayor diámetro al del orificio de aspiración.

■ Características constructivas:

Rodetes en latón, cuerpo bomba y soporte en fundición, eje en acero inoxidable.

Presión máxima admitida CB-100: 6 bar.

CB 160/210/310/400/600/750: 10 bar.

Temperatura máxima del agua: 90° C.

■ Motor:

Cerrado, autoventilado, grado de protección IP44, versiones monofásicas con protección térmica y condensador incorporados.

■ Applications:

Double impeller centrifugal pumps particularly suitable for use in pressure units.

Maximum suction 7 m.c.a.. In the case of suctions of over 4 m.c.a., install a pipe with a wider diameter of the Suction hole .

■ Construction:

Brass impellers, pump body and support in cast iron, stainless steel shaft.

Maximum pressure admitted CB-100: 6 bar.

CB 160/210/310/400/600/750: 10 bar.

Maximum water temperature: 90° C.

■ Motor:

Sealed, self-ventilated, IP-44 protection, single phase versions with built-in thermal protection and capacitor.

Tipo Type	Potencia		"A"			Cond. µF	Caudal m ³ /h / Flow m ³ /h								Diámetro		
	HP	KW	II 230	III 230	III 400		0,9	1,8	2,7	3,6	4,8	6	7,2	11	13,8	ASP.	IMP.
CB 100 M	1	0,75	5,5	-	-	20	44	41	38	33	23					1"	1"
CB 100T			-	4,3	2,5												
CB 160 M	1,5	1,1	8,8	-	-	31,5	53	53	50	46	44	40				1 1/4"	1"
CB 160T			-	5,8	3,4												
CB 210 M	2,2	1,7	10	-	-	31,5	58	58	56	53	47	44	29			1 1/4"	1"
CB 210T			-	7,8	4,2												
CB 310T	3	2,2	-	9,2	5,3	-	65	65	62	59	54	50	37			1 1/4"	1"
CB 400T	4	3	-	14	8	-	69	69	68	66	63	59	58	45		1 1/2"	1"
CB 600T	5,5	4	-	15,5	9,8	-	81	81	80	78	76	72	70	58		1 1/2"	1"
CB 750T	7,5	5,5	-	20	11,6	-	92	92	91	90	88	85	82	70	62	1 1/2"	1"

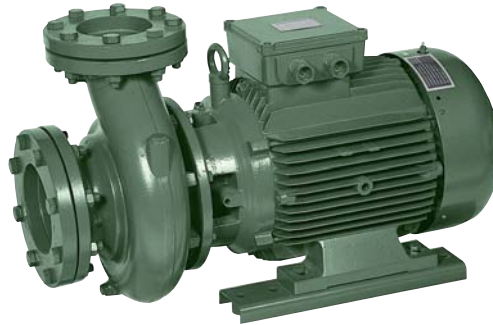

A

■ Aplicaciones:

Bomba centrífuga monoturbina especialmente diseñada para suministro de agua primaria o circuitos de recirculación de agua caliente o aire acondicionado.

■ Características Constructivas:

Cuerpo de bomba, soporte y turbina en fundición, excepto Serie HK-10 (tecnopolímero) con tratamiento anticorrosivo incluso en su superficie interna, eje en acero inox. y sello en carbono cerámica.

■ Motor:

De tipo asíncrono, hermético y ventilación externa, protección de seguridad incorporada grado IP-44 y aislamiento tipo F, a partir de 7,5 CV voltaje habitual 400/690.

Temperatura del líquido a bombear:

-15° C a + 110° C (Serie HK-10: -10° C a + 50° C)

Máxima temperatura ambiente: 40° C

Presión máxima admitida:

- HK-10 / HK-25: 6 Kg./cm²
- HK-40 / HK-55: 8 Kg./cm²
- HK-75-100-101-102-125-126-150-151: 10 Kg./cm²

■ Applications:

A single impeller centrifugal pump especially designed for supplying primary water or hot water recirculation circuits or Air Conditioning.

■ Construction:

Pump body, support and impeller in cast iron, except for the HK-10 (Techno polymer) with rust-proof treatment, including the internal surface, stainless steel shaft, and ceramic carbon seal.

■ Motor:

Sealed asynchronous motor with external ventilation, built-in IP-44 thermal protection and type F insulation. Standard voltage 400/690 volts from 7.5 HP.

Maximum water temperature:

From -15° to +110° C. (HK-10 From -10° to +50° C).

Maximun Ambient temperature: +40° C

Maximun Pressure admitted:

- HK-10 / HK-25: 6 Kg./cm²
- HK-40 / HK-55: 8 Kg./cm²
- HK-75-100-101-102-125-126-150-151: 10 Kg./cm²

Tipo Type	Potencia		"A"			Cond. µF	Caudal m ³ /h / Flow m ³ /h												Diámetro		
	HP	KW	II	III	III		6	9	12	18	24	30	36	42	48	60	72	90	ASP.	IMP.	
			230	230	400		Altura m.c.a. / Height w.c.m.														
HK-10-M	1	0,75	4,6	-	-	20	15	13	12	7										1 1/2"	1 1/2"
HK-10-T			-	3,6	2,1	-															
HK-25-M	2,5	1,83	9,5	-	-	40			18	17	16	13	12							2"	2"
HK-25-T			-	7,4	4,3	-															
HK40	4	3	-	10,2	5,9	-			29	27	25	19	13							2 1/2"	2"
HK55	5,5	4	-	14,7	8,5	-			35	33	30	25	19	10						2 1/2"	2"
HK75	7,5	5,5	-	-	11,5	-		50	49	45	37	24								65	50
HK100	10	7,5	-	-	15	-		62	61	57	54	44	25							65	50
HK101	10	7,5	-	-	14	-			44	43	42	41	38	35	31	23				80	65
HK102	10	7,5	-	-	15,4	-			37	36	36	35	34	33	30	24	17			80	65
HK125	12,5	9,2	-	-	18	-			51	50	48	47	44	41	31					80	65
HK126			-	-	18	-			41	40	39	38	38	37	35	34	29	21			80
HK150	15	11	-	-	20,5	-			56	55	54	53	51	47	40	32				80	65
HK151			-	-	19,3	-			45	44	44	43	42	42	41	38	35	28			80

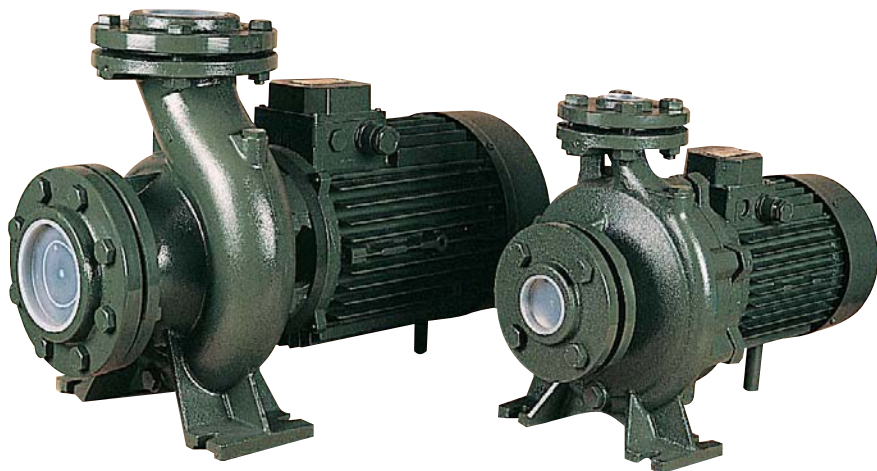

■ Aplicaciones:

Electrobombas Centrífugas Normalizadas cuya construcción es según normas **DIN-24255 - NFE44-III-UNI 7467**.

Estas bombas son aptas para el bombeo de agua limpia y otros líquidos químicamente no agresivos.

Posibilidad de montaje en cualquier posición exceptuando la que requiere el orificio de aspiración hacia arriba.

Bomba ideal para su uso en riegos, equipos de presión, instalaciones de climatización y otras instalaciones del sector civil, industrial o agrario.

Temperatura máxima del agua SERIE "MN" + 90° C

Temperatura máxima ambiente + 40° C

Presión máxima de trabajo 10 Bar

■ Características constructivas:

Cuerpo de bomba, soporte bomba motor y turbina en fundición de alta resistencia, orificios de aspiración e impulsión con bridas según normas **UNI 2236 PN 10**. Eje en acero inoxidable.

■ Motor:

Motor de inducción, tipo cerrado y autoventilado, apto para trabajo continuo. Grado de protección IP-44 y aislamiento clase B.

Los motores de la Serie "MN" son todos a 2.850 r.p.m.

A partir de 7,5 CV voltaje habitual 400/690 V (bajo demanda 230-400 V).

■ Applications:

Standardised Centrifugal Electropumps built as per DIN - 24255 - NFE44-III-UNI 7467.

These pumps are suitable for pumping clean water and other liquids that are not chemically aggressive.

They may be assembled in any position except for positions requiring the suction hole to point upwards.

An ideal pump for use in sprinkling, pressure units, air conditioning units and other installations in the civil, industrial or agricultural sectors.

Maximum water temperature in the "MN" SERIES + 90° C

Maximum ambient temperature + 40° C

Maximum working pressure 10 Bar

■ Construction:

Pump body, pump motor support and impeller in high-strength cast iron inlet and outlet holes with flanges as per **UNI 2236 PN 10**. Stainless steel shaft.

■ Motor:

Induction motor, sealed and self-ventilated, suitable for continuous work. IP-44 protection and class B insulation.

The "MN" Series motors are all 2,850 rpm..

STANDARD voltage FROM 7.5 HP IS 400/690 V (230-400 V UNDER DEMAND).

Centrífugas normalizadas Monobloc

Serie "MN"

A

Tipo Type	Potencia		"A"		Caudal m ³ /h / Flow m ³ /h											Diámetro	
	HP	KW	III 230	III 400	0	4,5	6	7,5	9	12	15	18	21	24	30	ASP.	IMP.
					Altura m.c.a. / Height w.c.m.												
MN 32-160 C	2	1,5	6,4	4	24,7	24,4	24,1	23,6	23	21,5	19,6	17,2	14,1			50	32
MN 32-160 B	3	2,2	8,5	5,2	29	29	28,5	28	27,3	25,7	23,8	21,4	18,5	14,8		50	32
MN 32-160 A	4	3	11,8	7,1	36,8	36,6	36,4	36	35,4	34,2	32,8	31,1	28,8	26	20	50	32
MN 32-200 C	5,5	4	16,2	9,4	41	41	40	39,5	38,8	37,5	36	34,2	32,2	30	25	50	32
MN 32-200 B	7,5	5,5	-	14,2	53	53	52	51,5	51	50	48,5	46,8	45	42,7	37	50	32
MN 32-200 A	10	7,5	-	16,5	61	61	60,5	60	59,5	58,5	57,2	55,5	53,7	51,5	46,2	50	32
MN 32-250 C	12,5	9,2	-	20,1	70	70	69	68,5	68	67	65,5	63,5	61,5	58,7	50,5	50	32
MN 32-250 B	15	11	-	24,2	82	82	81,5	81	80,5	79,5	78,5	77	75	72,6	66,5	50	32
MN 32-250 A	20	15	-	30,1	93	93	92,7	92,5	92	91,5	90,5	89,5	88	85,7	80	50	32

El modelo MN 32-160 C (2 HP) puede suministrarse en versión monofásica.
 The model MN 32-160 C (2 HP) can be supplied with single phase motor.

Tipo Type	Potencia		"A"		Caudal m ³ /h / Flow m ³ /h											Diámetro	
	HP	KW	III 230	III 400	0	9	12	15	18	21	24	27	30	36	42	ASP.	IMP.
					Altura m.c.a. / Height w.c.m.												
MN 40-125 C	2	1,5	6,4	4	17,7	17,5	17,3	16,9	16,4	15,8	15,1	14,2	13,3			65	40
MN 40-125 B	3	2,2	8,5	5,2	21,5	21,3	21,2	21	20,6	20,1	19,4	18,7	17,9			65	40
MN 40-125 A	4	3	11,8	7,1	26	25,8	25,8	25,6	25,4	24,9	24,4	23,7	22,9	21,1		65	40
MN 40-160 B	4	3	13	7,4	30,3	30,1	30	29,6	29	28,2	27,1	25,9	24,4	21		65	40
MN 40-160 A	5,5	4	18	9,9	35,8	35,6	35,5	35,3	35	34,2	33,2	32	30,6	27,3		65	40
MN 40-200 B	7,5	5,5	24	13,2	47,5	47	46,8	46,4	45,6	44,5	43,2	41,6	39,9	35,8		65	40
MN 40-200 A	10	7,5	31	16,8	58	58	58	57,9	57,6	56,9	56	54,7	53	48,9	43,9	65	40
MN 40-250 B	15	11	-	24,2	75	74,6	74,2	73,5	72,7	71,7	70,4	69	67,2	62,5	56	65	40
MN 40-250 A	20	15	-	32	92	90,4	89,8	89,3	88,5	87,5	86,6	85,5	84	80,5	76	65	40

Tipo Type	Potencia		"A"		Caudal m ³ /h / Flow m ³ /h											Diámetro	
	HP	KW	III 400	III 690	0	24	27	30	36	42	48	54	60	66	72	ASP.	IMP.
					Altura m.c.a. / Height w.c.m.												
MN 50-125 B	4	3	7,4	-	19,9	19,8	19,3	19,1	18,3	17,4	16,4	15,3	14	12,7	11,2	65	50
MN 50-125 A	5,5	4	9,9	-	24,7	24,6	24,4	24,2	23,5	22,7	21,8	20,8	19,6	18,1	16,5	65	50
MN 50-160 B	7,5	5,5	11,6	6,7	30,4	30,3	30,1	29,8	29	28	26,7	25,1	23,3	21,3	19,1	65	50
MN 50-160 A	10	7,5	15,8	9	37	36,9	36,8	36,6	36,1	35,1	34	32,6	31	29,1	26,9	65	50
MN 50-200 C	12,5	9,2	18,5	10	47	45,7	45,1	44,5	42,9	40,2	38,5	35,9	33	29	24,5	65	50
MN 50-200 B	15	11	21	12	52	51	50,5	50	48,5	46,8	44,7	42,2	39,5	35,9	32	65	50
MN 50-200 A	20	15	27	16	58,5	58,1	58	57,5	56,4	55	53,2	51,3	49	46,3	42,8	65	50
MN 50-250 C	20	15	32,5	18	71,5	70,8	70,8	70,3	69	67,6	66	64	61,5	58,6	55	65	50
MN 50-250 B	25	18,5	41,5	24	78	78	78	77,4	76,1	74,5	72,8	70,6	68,2	65,5	62,2	65	50
MN 50-250 A	30	22,5	51,5	30	90	89,5	89,5	88,8	87,7	86,1	84,5	82,7	80,5	78	75,2	65	50

Tipo Type	Potencia		"A"		Caudal m ³ /h / Flow m ³ /h										Diámetro		
	HP	KW	III 400	III 690	0	48	54	66	72	84	96	108	120	132	144	ASP.	IMP.
					Altura m.c.a. / Height w.c.m.												
MN 65-125 B	7,5	5,5	12,3	-	19,8	20,4	20,1	19,3	18,8	17,7	16,1	14,3	12,3			80	65
MN 65-125 A	10	7,5	15,9	-	24,2	24,3	24,1	23,7	23,4	22,3	20,9	19,4	17,5	15		80	65
MN 65-160 C	12,5	9,2	19,5	11	32	31,1	30,8	30,1	29,6	28,3	26,6	24,6	22,1	19,3	16	80	65
MN 65-160 B	15	11	22,5	13	35	34,4	34,2	33,7	33,3	32,1	30,6	28,8	26,7	24,1	21,1	80	65
MN 65-160 A	20	15	30	17	41	40,6	40,4	40	39,7	38,9	37,7	36,2	34,3	32,2	29,8	80	65
MN 65-200 C	20	15	32,5	18	45	44,8	44,8	44,1	43,7	42,3	40,5	38	35,3	32		80	65
MN 65-200 B	25	18,5	41,5	24	50	49,5	49,5	49	48,5	47,3	45,5	43,5	41	38		80	65
MN 65-200 A	30	22,5	51,5	30	57	56,7	56,7	56,2	55,7	54,7	53,3	51,6	49,6	47,1	44	80	65

Tipo Type	Potencia		"A"		Caudal m ³ /h / Flow m ³ /h										Diámetro		
	HP	KW	III 400	III 690	0	72	84	96	108	120	144	156	180	200	225	ASP.	IMP.
					Altura m.c.a. / Height w.c.m.												
MN 80-160 D	15	11	20,8	12	24	25,3	25,1	23,9	22,9	21,8	19,3	17,9	14,6			100	80
MN 80-160 C	20	15	25,8	15	29	29,6	29	28,1	27	25,9	23,4	22,0	18,7	16,4		100	80
MN 80-160 B	25	18,5	35	20	33,5	34,1	33,4	32,7	32	31	29	27,7	25	22,9		100	80
MN 80-160 A	30	22,5	42	25	37	34,2	37,3	36,9	36,2	35,5	33,5	32,4	29,9	28	22,9	100	80

Normalizadas Monobloc 1.450 - 2.900 r.p.m. Serie "NKM-G - NKP-G"

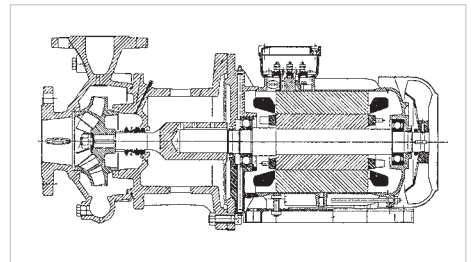

■ Aplicaciones:

Bombas centrífugas Monobloc Normalizadas según Normativa DIN 24255 (DIN EN733 actual).

Con acoplamiento para equipar un motor totalmente Normalizado, ideales para una amplia gama de aplicaciones como pueden ser:

- Circulación de agua para circuitos de calefacción y refrigeración.
- Montajes en equipos de presión.
- Riegos.
- Otras instalaciones del sector civil, industrial o agrario.

Pueden instalarse en posición horizontal o vertical pero con el motor siempre encima de la bomba.

■ Características Constructivas:

Cuerpo bomba, soporte y turbina en fundición de hierro de alta resistencia.

Eje bomba que hace a su vez la función de acoplamiento en acero inoxidable AISI 304. Sello mecánico normalizado según DIN 24960 en carbón / carburo de silicio con juntas tóricas en EPDM.

Bajo demanda las turbinas pueden ser en Bronce.

■ Motor:

Motor asíncrono, cerrado de ventilación externa de forma constructiva B3/B5. Aislamiento clase F, con grado de protección IP55 y tropicalizado. Todos los motores son multifrecuencia y multitensión.

A partir de 15CV (Mec 160) todos los motores incorporan de serie engrasador de cojinetes y sonda de temperatura. Los motores de esta serie pueden ser a 1.450 r.p.m. o 2.900 r.p.m..

Campo de temperatura de líquido bombeado: de -10° C a +140° C.

■ Applications:

En bloc, centrifugal motor-driven pumps with coupling designed for a wide range of applications such as:

- Supplying water.
- The circulation of hot water for the central heating.
- The circulation of cold water for air conditioning.
- The transfers of liquids in agriculture, industries.
- The implementation of pumping systems.

■ Constructional features of the pump:

Single-stage, cast iron spiral body made to DIN-EN 733 (formerly DIN 24255), cast iron support, flanges in accordance with DIN 2533 and DIN 2532 for DN 200. Impeller in cast iron, encased and dynamically balanced with compensation of the axial thrust by means of balancing holes, operating (on request) with interchangeable wear rings. AISI 304 stainless steel pump shaft. Standardised mechanical seal made to DIN 24960 in carbon/silicium carbide with O-rings in EPDM.

■ Constructional features of the motor:

Closed, asynchronous motor with external ventilation, construction type B3/B5, 2 poles for NKP, and 4 poles for NKM. The rotor is mounted on extra large ball bearings to guarantee low noise running and durability. We recommend using overload protection for the motor, in accordance with current norms. In the case of liquids denser than water, the motors must be proportionally more powerful.

MODELO MODEL	P2 NOMINAL		Q m³/h l/min	0	6	12	18	24	30	36	42	48	54	60	
	HP	KW		0	100	200	300	400	500	600	700	800	900	1000	
NKM-G 32-125.1 - 140 - 0.25 A A	0,33	0,25	H (m)	6,2	5,8	4,2									
NKM-G 32-125 - 142 - 0.37 A A	0,5	0,37		7	6,75	5,85	4,2								
NKM-G 32-160.1 - 169 - 0.37 A A	0,5	0,37		9,6	8,3	5,3									
NKM-G 32-160 - 169 - 0.55 A A	0,75	0,55		9,4	9	8,8	5,6								
NKM-G 32-200.1 - 200 - 0.55 A A	0,75	0,55		13,4	11,5	7,2									
NKM-G 32-200 - 200 - 0.75 A A	1	0,75		13	12,5	11,1	8,45								
NKM-G 32-200 - 219 - 1.1 A A	1,5	1,1		16	15,4	14,3	12,2								
NKM-G 40-125 - 115 - 0.25 A A	0,33	0,25		4,2	4,1	3,7	3	2,1							
NKM-G 40-125 - 130 - 0.37 A A	0,5	0,37		5,4	5,3	5	4,4	3,5							
NKM-G 40-125 - 142 - 0.55 A A	0,75	0,55		6,6	6,5	6,2	5,7	4,8							
NKM-G 40-160 - 153 - 0.55 A A	0,75	0,55		7,6	7,7	7,6	6,7	5,5							
NKM-G 40-160 - 166 - 0.75 A A	1	0,75		9,2	9,2	9	8,4	7,4	5,7						
NKM-G 40-200 - 200 - 1.1 A A	1,5	1,1		12,6	12,6	12,3	11,2	9,7	7,7						
NKM-G 40-200 - 219 - 1.5 A A	2	1,5		15,6	15,6	15,3	14,7	13,4	11,8	9,8					
NKM-G 40-250 - 245 - 2.2 A A	3	2,2		20,6	20,5	20,1	19,2	17,8	16						
NKM-G 40-250 - 260 - 3 A A	4	3		23,3	23,1	22,8	22,2	20,8	19						
NKM-G 50-125 - 130 - 0.55 A A	0,75	0,55		5,5		5,2	5	4,7	4,3	3,9	3,3	2,6			
NKM-G 50-125 - 141 - 0.75 A A	1	0,75		6,5		6,3	6,1	5,8	5,5	5	4,5	3,9			
NKM-G 50-160 - 161 - 1.1 A A	1,5	1,1		8,7		8,7	8,5	8,2	7,8	7,3	6,7	5,7			
NKM-G 50-160 - 177 - 1.5 A A	2	1,5		10,8		10,8	10,7	10,5	10,2	9,8	9,2	8,3			
NKM-G 50-200 - 210 - 2.2 A A	3	2,2		15,3		15,3	15,2	14,8	14	13,3	12,1	10,8	9,4		
NKM-G 50-200 - 219 - 3 A A	4	3		16,8		16,8	16,5	16,1	15,5	14,6	13,6	12,4	10,9		
NKM-G 50-250 - 263 - 4 A A	5,5	4		23,8		24	23,8	23,4	22,7	21,6	20,4	19	17,1		
NKM-G 65-125 - 130 - 0.75 A A	1	0,75		5,1	4,9	4,8	4,75	4,7	4,4	4,2	3,8	3,4	3		
NKM-G 65-125 - 144 - 1.1 A A	1,5	1,1		6,5	6,4	6,4	6,3	6,2	6	5,75	5,5	5,1	4,7		
NKM-G 65-160 - 153 - 1.1 A A	1,5	1,1		7,4		7,4	7,3	7,15	6,9	6,65	6,25	5,8	5,3	4,4	
NKM-G 65-160 - 165 - 1.5 A A	2	1,5		8,9			8,8	8,7	8,6	8,3	8	7,6	7,15	6,6	
NKM-G 65-160 - 177 - 2.2 A A	3	2,2		10,5				10,4	10,3	10,2	9,9	9,6	9,2	8,8	
NKM-G 65-200 - 210 - 3 A A	4	3		15,3				15,4	15,3	15	14,6	14,1	13,5	12,9	
NKM-G 65-200 - 219 - 4 A A	5,5	4		17				17,2	17,2	17,1	16,8	16,5	16,2	15,7	
NKM-G 65-250 - 263 - 5.5 A A	7,5	5,5		24,1				23,8	23,6	23,3	22,8	22,3	21,5	20,8	
NKM-G 65-315 - 279 - 7.5 A A	10	7,5		27							26	25,5	25	24,5	
NKM-G 65-315 - 309 - 11 A A	15	11		34,2							33,2	33	32,5	32	
NKM-G 80-160 - 153 - 1.5 A A	2	1,5		6,5					6,35	6,3	6,2	5,95	5,75	5,5	
NKM-G 80-160 - 163 - 2.2 A A	3	2,2		8,65					8,5	8,45	8,3	8,15	7,9	7,7	
NKM-G 80-160 - 177 - 3 A A	4	3		10,2					10,2	10,1	10	9,9	9,75	9,7	
NKM-G 80-200 - 200 - 4 A A	5,5	4		13,2							13,2	13,2	13,1	12,9	
NKM-G 80-200 - 222 - 5.5 A A	7,5	5,5		16,5							16,6	16,5	16,4	16,2	
NKM-G 80-250 - 240 - 7.5 A A	10	7,5		20,5							21	21	21	20,7	
NKM-G 80-250 - 270 - 11 A A	15	11		25,5							25,5	25,5	25,5	25,1	
NKM-G 80-315 - 305 - 15 A A	20	15		32,9									33,1	33	
NKM-G 80-315 - 320 - 18.5 A A	25	18,5		36,8									37,1	37	
NKM-G 80-315 - 334 - 22 A A	30	22		41									41,4	41,4	
NKM-G 100-200 - 200 - 5.5 A A	7,5	5,5		12,7										12,6	
NKM-G 100-200 - 214 - 7.5 A A	10	7,5		15,6										15,4	
NKM-G 100-250 - 250 - 11 A A	15	11	21										21,5		
NKM-G 100-250 - 270 - 15 A A	20	15	25,5										25,5		
NKM-G 100-315 - 300 - 18.5 A A	25	18,5	32												
NKM-G 100-315 - 316 - 22 A A	30	22	36												
NKM-G 125-250 - 243 - 15 A A	20	15	19,5												
NKM-G 125-250 - 256 - 18.5 A A	25	18,5	22												
NKM-G 125-250 - 266 - 22 A A	30	22	24,6												
NKM-G 150-200 - 218 - 11 A A	15	11	13,2												

MODELO MODEL	P2 NOMINAL		Q m³/h l/min	0	6	12	18	24	30	36	42	48	54	60	
	HP	KW		0	100	200	300	400	500	600	700	800	900	1000	
NKP-G 32-125.1 - 102 - 0.75 A A	1	0,75	H (m)	13	12,5	11	8								
NKP-G 32-125.1 - 115 - 1.1 A A	1,5	1,1		17,2	17	15	12,5								
NKP-G 32-125.1 - 125 - 1.5 A A	2	1,5		21	20,8	19	16,8								
NKP-G 32-125.1 - 140 - 2.2 A A	3	2,2		27	26,9	25,9	23	19,5							
NKP-G 32-125 - 110 - 1.1 A A	1,5	1,1		15,8	15,4	14,5	12,9	9,9							
NKP-G 32-125 - 120 - 1.5 A A	2	1,5		19,4	19	18,2	16,8	14,5							
NKP-G 32-125 - 130 - 2.2 A A	3	2,2		23,7	23,4	23	21,8	19,8	16,8						
NKP-G 32-125 - 142 - 3 A A	4	3		28,6	28,2	27,6	26,5	24,6	21,8	17,9					
NKP-G 32-160.1 - 155 - 2.2 A A	3	2,2		32	31	27	22								
NKP-G 32-160.1 - 166 - 3 A A	4	3		38	36	33	28								
NKP-G 32-160 - 151 - 3 A A	4	3		30,5	30	29	27	24	19,5						
NKP-G 32-160 - 163 - 4 A A	5,5	4		36	36	35	33,5	30,5	27	22					
NKP-G 32-160 - 177 - 5.5 A A	7,5	5,5		43,5	43,2	42,6	41,5	39	36	31,5	25,5				
NKP-G 32-200.1 - 188 - 4 A A	5,5	4		51	48	44	37								
NKP-G 32-200.1 - 205 - 5.5 A A	7,5	5,5		57	56	52	46	35							
NKP-G 32-200 - 190 - 5.5 A A	7,5	5,5		47	46,5	45	43	40	35	29					
NKP-G 32-200 - 210 - 7.5 A A	10	7,5		58,5	58	57	56	53	49	44					
NKP-G 40-125 - 107 - 1.5 A A	2	1,5		14,7	14,5	14,3	13,8	13	11,8	10,5	8,6	7			
NKP-G 40-125 - 120 - 2.2 A A	3	2,2		19	18,7	18,4	17,8	17	15,9	14,6	13	11			
NKP-G 40-125 - 130 - 3 A A	4	3		22,8	22,5	22,3	22	21,2	20,2	19	17,4	15,5	13,5		
NKP-G 40-125 - 139 - 4 A A	5,5	4		26,4	26,2	26	25,6	25	24	23	21,5	19,5	17,5	15	
NKP-G 40-160 - 158 - 5.5 A A	7,5	5,5		34			34	33,5	32,5	31	29,5	27	24		
NKP-G 40-160 - 172 - 7.5 A A	10	7,5		41			41	41	40	39	37,5	35,5	33	30	
NKP-G 40-200 - 210 - 11 A A	15	11		57	57,5	58	58	57,5	57	55	53	50	47	43,5	
NKP-G 40-250 - 230 - 15 A A	20	15		72,5			72,5	72	70	68	66	62,5	60	56	
NKP-G 40-250 - 245 - 18.5 A A	25	18,5		83			83	82,5	81,5	80	77	74	71,5	67,5	
NKP-G 40-250 - 260 - 22 A A	30	22		96			96	94,5	93,5	92	90	87,5	84	81	
NKP-G 50-125 - 115 - 3 A A	4	3		17				16,5	16	15,5	15	14,5	13,7	13	
NKP-G 50-125 - 125 - 4 A A	5,5	4		20,5				20	19,5	19,1	18,5	18	17,5	16,5	
NKP-G 50-125 - 135 - 5.5 A A	7,5	5,5		24				23,6	23,5	23,2	22,8	22,2	21,5	21	
NKP-G 50-125 - 144 - 7.5 A A	10	7,5		28				27,8	27,5	27,3	27	26,5	25,8	25,5	
NKP-G 50-160 - 153 - 7.5 A A	10	7,5		32				32,5	32,4	32	31,5	31	30,5	29,5	
NKP-G 50-160 - 169 - 11 A A	15	11		39,5					40	39,8	39,5	39	38,5	38	
NKP-G 50-200 - 200 - 15 A A	20	15		55					56	55,5	54	53,5	52	51	
NKP-G 50-200 - 210 - 18.5 A A	25	18,5		61,5					62	62	61,5	60,5	59	58	
NKP-G 50-200 - 219 - 22 A A	30	22		67,5					68	67,5	67	66	65,5	64	
NKP-G 50-250 - 230 - 22 A A	30	22		73,5					75	74,5	73,8	73,5	71	68,5	
NKP-G 50-250 - 257 - 30 A A	40	30		92,5					94	94	93,6	93,5	91	89	
NKP-G 65-125 - 120/110 - 4 A A	5,5	4		16						15	14,6	14,2	13,7	13,3	
NKP-G 65-125 - 127 - 5.5 A A	7,5	5,5		19,5						19	18,9	18,7	18,4	18,1	
NKP-G 65-125 - 137 - 7.5 A A	10	7,5	23,5						23,1	23	22,8	22,6	22,5		
NKP-G 65-160 - 157 - 11 A A	15	11	32,5								32,2	32	31,8		
NKP-G 65-160 - 173 - 15 A A	20	15	40								40,2	40	39,8		
NKP-G 65-200 - 190 - 18.5 A A	25	18,5	51,5								52	52	51,5		
NKP-G 65-200 - 200 - 22 A A	30	22	56,5								58	58	57,5		
NKP-G 65-200 - 219 - 30 A A	40	30	68,5								70	70	70		
NKP-G 80-160 - 147/127 - 11 A A	15	11	24												
NKP-G 80-160 - 153 - 15 A A	20	15	30,5												
NKP-G 80-160 - 163 - 18.5 A A	25	18,5	35,5												
NKP-G 80-160 - 169 - 22 A A	30	22	38,5												
NKP-G 80-200 - 190 - 30 A A	40	30	48												



■ Aplicaciones:

Bombas centrífugas a eje libre o sobre bancada normalizadas según Normativa DIN 24255 (DIN EN733 actual).

Ideales para una amplia gama de aplicaciones como puedan ser:

- Circulación de agua para circuitos de calefacción y refrigeración.
- Montajes en equipos de presión.
- Riegos.

- Otras instalaciones del sector civil, industrial o agrario.

Pueden ser acopladas con un acoplamiento elástico a un motor de 1.450 - 2.900 r.p.m. y montada sobre una bancada rígida.

Bajo demanda las turbinas pueden ser en bronce.

■ Características Constructivas:

Cuerpo bomba, tapa porta sello mecánico, soporte en fundición de hierro. Turbina en fundición de hierro cerrada y equilibrada dinámicamente con compensación del esfuerzo axial. Eje bomba en Acero Inoxidable AISI 304 soportado por dos cojinetes de esferas ampliamente dimensionadas, engrasadas de por vida y alojadas en una cámara en el interior del soporte.

Cierre mecánico normalizado según la DIN 24960 en carbón - carburo de silicio con juntas tóricas EPDM.

Bajo demanda empaquetadura o estopada con anillos hidráulicos de lubricación en lugar de sello mecánico convencional.

■ Motor:

Motor asincrónico, cerrado de ventilación externa de forma constructiva B3. Aislamiento clase F, con grado de protección IP55 y tropicalizado. Todos los motores son multifrecuencia y multiten-sión.

A partir de 15CV (Mec 160) todos los motores incorporan de serie engrasador de cojinetes y sonda de temperatura. Los motores de esta serie pueden ser a 1.450 r.p.m. o 2.900 r.p.m..

Campo de temperatura de líquido bombeado: de -10° C a +140° C.

■ Applications:

Bare –shaft, Enbloc, centrifugal motor-driven pumps with coupling designed for a wide range of applications such as:

- *Supplying water.*
- *The circulation of hot water for the central heating.*
- *The circulation of cold water for air conditioning.*
- *The transfers of liquids in agriculture, industries.*
- *The implementation of pumping systems.*

■ Constructional features of the pump:

Single-stage, cast iron spiral body made to DIN-EN 733 (formerly DIN 24255), cast iron support, flanges in accordance with DIN 2533 and DIN 2532 for DN 200. Impeller in cast iron, encased and dynamically balanced with compensation of the axial thrust by means of balancing holes, operating (on request) with interchangeable wear rings. AISI 304 stainless steel pump shaft. Standardised mechanical seal made to DIN 24960 in carbon/silicium carbide with O' rings in EPDM. Packing with lubricating hydraulic ring and stuffing box in two easily removable parts, available on request.

■ Constructional features of the motor:

Closed, asynchronous motor with external ventilation, construction type B3 for 2 poles and 4 poles. The rotor is mounted on extra large ball bearings to guarantee low noise running and durability. We recommend using overload protection for the motor, in accordance with current norms. In the case of liquids denser than water, the motors must be proportionally more powerful. ip-55 protection insulation F.



MODELO / MODEL	Q m ³ /h l/min	0	3	6	12	18	24	30	36	42	48	54
		0	50	100	200	300	400	500	500	700	800	900
KDN 32-125.1 / 105		13,8-1,5		13,6-1,5	12,3-1,5	9,7-1,5						
KDN 32-125.1 / 110		15,5-1,5		15,2-1,5	13,9-2	11,5-2						
KDN 32-125.1 / 115		17,1-1,5		16,8-1,5	15,5-2	13,2-2						
KDN 32-125.1 / 120		18,8-2		18,5-2	17,3-2	15,1-3						
KDN 32-125.1 / 125		20,5-2		20,3-2	19,1-3	17-3						
KDN 32-125.1 / 130		22,3-2		22,1-2	21,3-3	19-3						
KDN 32-125.1 / 135		24,4-2		24,1-2	23,3-3	21,1-4	17,8-4					
KDN 32-125.1 / 140		26,5-2		26,4-2	25,6-3	23-4	20,1-5,5					
KDN 32-125 / 115		17,3-2			16,5-2	15,1-3	12,9-3					
KDN 32-125 / 120		19-2			18,2-2	17-3	14,9-3	11,1-3				
KDN 32-125 / 125		20,9-3			20,1-3	18,9-3	16,9-3	13,5-3				
KDN 32-125 / 130		22,9-3			22-3	21-3	19,1-4	16,2-4				
KDN 32-125 / 135		24,9-3			24-3	22,1-4	21,5-4	18,5-5,5	14,7-5,5			
KDN 32-125 / 142		27,8-4			27-4	26,1-4	24,5-5,5	21,7-5,5	18-5,5			
KDN 32-160.1 / 137		24-2		22-2	18,8-3							
KDN 32-160.1 / 145		27-2		25,5-2	22-3	15,5-3						
KDN 32-160.1 / 153		30-3		28,5-3	25,5-3	20-4						
KDN 32-160.1 / 161		33-3		31,6-3	29-4	24,5-5,5						
KDN 32-160.1 / 169		36,5-3		35-3	32,5-4	28,5-5,5	21,7-7,5					
KDN 32-160.1 / 177		40,5-4		39-4	36,5-5,5	33-5,5	26,2-7,5					
KDN 32-160 / 137		23,7-3			22,6-3	20,7-4	17,6-4					
KDN 32-160 / 145		27-4			25,8-4	23,9-4	21,2-5,5	16,9-5,5				
KDN 32-160 / 153		30,4-4			29,5-4	27,7-5,5	25,8-5,5	21,2-7,5				
KDN 32-160 / 161		34-5,5			33-5,5	31,7-5,5	29,1-7,5	25,5-7,5				
KDN 32-160 / 169		38-5,5			37,3-5,5	36-7,5	33,6-7,5	35,7-7,5	26,5-10			
KDN 32-160 / 177		41,8-5,5			41,5-5,5	40,5-7,5	38,4-7,5	35,3-10	31,4-10			
KDN 32-200.1 / 170		37-4		35,5-4	31-4	23-4						
KDN 32-200.1 / 180		41,9-4		40-4	36-5,5	28,8-5,5						
KDN 32-200.1 / 190		46,5-5,5		45-5,5	41-5,5	35,5-7,5						
KDN 32-200.1 / 200		51,8-5,5		50-5,5	46,5-7,5	40,5-7,5	31-7,5					
KDN 32-200.1 / 207		55,1-7,5		54-7,5	50,5-7,5	45-10	35-10					
KDN 32-200 / 170		34-5,5			33-5,5	31-5,5	27-7,5	21-7,5				
KDN 32-200 / 180		39-5,5			38,5-5,5	36,5-7,5	32,5-7,5	28-7,5				
KDN 32-200 / 190		45-7,5			43,5-7,5	42-7,5	39-7,5	34-10	28,5-10			
KDN 32-200 / 200		51-7,5			49-7,5	48-7,5	45-10	40,5-10	35-10			
KDN 32-200 / 210		57-7,5			56-7,5	55-10	52,5-10	48,5-15	43-15	36-15		
KDN 32-200 / 219		63-10			62-10	61-10	59-15	56,5-15	52,5-15	46,5-15	39,5-15	

2.900 r.p.m.



H
(m)

MODELO / MODEL	Q m ³ /h l/min	0	3	6	12	18	24	30	36	42	48	54	60	
		0	50	100	200	300	400	500	600	700	800	900	1000	
KDN 40-125 / 115		16,8-3			13,3-3	15,6-3	15-3	14,3-4	13,2-4	12,6-4	9,8-4			
KDN 40-125 / 120		18,5-3			18-3	17,5-3	17-4	16-4	15-4	13,5-4	11,8-5,5			
KDN 40-125 / 125		20,4-4			20-4	19,5-4	19-4	18-4	16,7-5,5	15,3-5,5	13,5-5,5			
KDN 40-125 / 130		22-4			21,8-4	21,5-4	21-4	20-5,5	19-5,5	17,5-5,5	15,7-5,5	14-7,5		
KDN 40-125 / 135		24,1-4			24-4	23,9-4	23,4-5,5	22,5-5,5	21,5-7,5	20-7,5	18,3-7,5	16,4-7,5		
KDN 40-125 / 142		26,8-5,5			26,6-5,5	26,4-5,5	26-5,5	25,3-7,5	24,4-7,5	23-7,5	21,4-7,5	19,4-7,5	17-7,5	
KDN 40-160 / 137		24-4			24-4	23-4	22-5,5	20,5-5,5	18-7,5	15-7,5				
KDN 40-160 / 145		27,5-5,5			27,5-5,5	27-5,5	25,9-5,5	24,2-7,5	22,1-7,5	19,5-7,5				
KDN 40-160 / 153		31-7,5			31-7,5	30,5-7,5	29,5-7,5	28-7,5	26,5-7,5	24-10	21-10			
KDN 40-160 / 161		34,5-7,5			35-7,5	34,5-7,5	33,9-7,5	32-10	30,5-10	28,5-10	25,8-10	22,5-10		
KDN 40-160 / 169		38,5-7,5			39-7,5	38,5-7,5	38-10	37-10	35-10	33,5-15	31-15	28-15		
KDN 40-160 / 177		42,5-10			43-10	42,5-10	42-10	41,5-15	40-15	38,5-15	36-15	33-15		
KDN 40-200 / 170		33,5-7,5			34,5-7,5	33,5-7,5	32-7,5	30-7,5	26,5-10	22,5-10				
KDN 40-200 / 180		38,5-7,5			39,5-7,5	38,5-7,5	37-10	35-10	32,5-10	29-10	25-10			
KDN 40-200 / 190		43,5-10			44,5-10	44-10	43-10	41-10	38-15	35-15	31,5-15	27-15		
KDN 40-200 / 200		48,5-10			50-10	49,5-10	48,5-15	46,5-15	44-15	41,5-15	38,5-15	34,5-15		
KDN 40-200 / 210		54-15			55,5-15	55,5-15	54,5-15	53-15	51-15	48,5-15	46-20	42,5-20		
KDN 40-200 / 219		60-15			61-15	61-15	60,5-15	59-15	57-20	55-20	62,5-20	49,5-20		
KDN 40-250 / 220		63-15			63-15	62,5-15	61-15	59-15	57-20	55-20	52-20	48-20		
KDN 40-250 / 230		69,5-15			69,5-15	68,5-15	68-15	66-20	63,5-20	61-25	58-25	55-25		
KDN 40-250 / 240		76-20			76-20	76-20	75-20	73-20	70,5-25	68-25	65-25	62-30		
KDN 40-250 / 250		83-20			83-20	82,5-20	81,5-20	80-25	78-25	75,5-30	72,5-30	69-30		
KDN 40-250 / 260		91-25			90,5-25	90-25	89,5-25	88,5-25	86,5-30	84-30	81-30	78-40		
KDN 50-125 / 115	H (m)	16,8-4						16-4	15,5-4	15-4	14,3-5,5	13,6-5,5	13-5,5	
KDN 50-125 / 120			18,1-5,5						17,5-5,5	17-5,5	16,5-5,5	16-5,5	15,3-7,5	14,7-7,5
KDN 50-125 / 125			19,8-5,5						19,4-5,5	19-5,5	18,5-5,5	17,9-5,5	17,4-7,5	16,6-7,5
KDN 50-125 / 130			21,5-7,5						21,1-7,5	20,8-7,5	20,5-7,5	19,8-7,5	19,2-7,5	18,5-7,5
KDN 50-125 / 135			23,2-7,5						23-7,5	22,6-7,5	22,3-7,5	21,8-7,5	21,2-10	20,6-10
KDN 50-125 / 139			24,7-7,5						24,5-7,5	24,3-7,5	24-7,5	23,5-7,5	23-10	22,4-10
KDN 50-125 / 144			25,9-10						26,5-10	26,4-10	26,1-10	25,6-10	25,1-10	24,5-10
KDN 50-160 / 137			24-7,5						24-7,5	24-7,5	23,5-7,5	23-7,5	22,5-7,5	21-7,5
KDN 50-160 / 145			27,5-7,5						27,5-7,5	27,5-7,5	27-7,5	26-7,5	25,5-7,5	25-10
KDN 50-160 / 153			30,5-10						31-10	31-10	30,5-10	30-10	29,5-10	28,5-10
KDN 50-160 / 161			32-10						34,5-10	34,5-10	34-10	33,5-15	33,5-15	32,5-15
KDN 50-160 / 169			37,5-15						38,5-15	38,5-15	38-15	37,5-15	37,5-15	36,5-15
KDN 50-160 / 177			41,5-15						42,5-15	42,5-15	42-15	42,8-15	41,5-15	41-15
KDN 50-200 / 170			38-10						38-10	37,5-10	37-10	36-10	34-15	32-15
KDN 50-200 / 180			42,5-10						43-10	42,5-10	41,5-15	40,5-15	39,5-15	38-15
KDN 50-200 / 190			47-15						48-15	47,5-15	47-15	46-15	44,5-15	43,5-15
KDN 50-200 / 200			52,5-15						53,5-15	53-15	52,5-15	51,5-15	50,5-20	49-20
KDN 50-200 / 210			58,5-15						59-15	59-15	58,5-15	57,5-20	56,5-20	55,5-20
KDN 50-200 / 219			64-20						65-20	64,5-20	64-20	63,5-20	62,5-20	61,5-25
KDN 50-250 / 220			64-20						65-20	64,5-20	63-20	62-20	61-20	59-25
KDN 50-250 / 230			69-20						72-20	71-20	70-20	69-25	68-25	66-25
KDN 50-250 / 240			76-25						78-25	78-25	77-25	76-25	74,5-30	73-30
KDN 50-250 / 250			84-25						85,5-25	85-25	84,5-25	83,5-30	84-40	80,5-40
KDN 50-250 / 263			92-30						94-30	94-30	93,5-30	92,5-30	91,5-40	90-40

N.º negro: **Altura m.c.a.** - N.º verde: **Potencia Nominal en CV**

Nº black: **Height w.c.m.** - Nº Green: **Nominal Power HP**

MODELO / MODEL	Q m ³ /h l/min	0	3	6	12	18	24	30	36	42	48	54	60
		0	50	100	200	300	400	500	600	700	800	900	1000
KDN 65-125 / 120 / 110		16 - 75									14,4 - 75	14 - 75	13,6 - 75
KDN 65-125 / 120		17,8 - 75									16 - 75	15,6 - 75	15,3 - 75
KDN 65-125 / 125		19,4 - 75									17,8 - 75	17,5 - 75	17,1 - 75
KDN 65-125 / 130		21 - 75									19,6 - 75	19,5 - 75	19,1 - 75
KDN 65-125 / 135		22,6 - 10									21,8 - 10	21,5 - 10	21,3 - 10
KDN 65-125 / 140		24 - 10									23,6 - 10	23,5 - 10	23,4 - 10
KDN 65-125 / 144		25,6 - 15									25,6 - 15	25,5 - 15	25,3 - 15
KDN 65-160 / 137		23 - 10									22,7 - 10	22,5 - 10	22 - 10
KDN 65-160 / 145		26 - 10									26 - 10	25,5 - 10	25 - 10
KDN 65-160 / 153		29 - 15									29,5 - 15	29 - 15	28,7 - 15
KDN 65-160 / 161		32,5 - 15									33 - 15	32,7 - 15	32,5 - 15
KDN 65-160 / 169		36,5 - 15									36,6 - 15	36,5 - 15	36,4 - 15
KDN 65-160 / 177		40 - 20									40,5 - 20	40,5 - 20	40,3 - 20
KDN 65-200 / 170		37 - 15									38,5 - 15	38 - 15	37,5 - 15
KDN 65-200 / 180		42 - 15									43 - 15	43 - 15	42,5 - 15
KDN 65-200 / 190		48 - 20									49,5 - 20	49 - 20	48,5 - 20
KDN 65-200 / 200		53 - 20									54,5 - 20	54,5 - 20	54,5 - 20
KDN 65-200 / 210		59 - 25									60,5 - 25	60,5 - 25	60 - 25
KDN 65-200 / 219		65 - 25									66,5 - 25	66,5 - 25	66 - 25
KDN 65-250 / 220		63 - 25									63 - 25	62,5 - 25	62 - 25
KDN 65-250 / 230		69,5 - 30									69,5 - 30	69 - 30	68,5 - 30
KDN 65-250 / 240		76 - 40									76 - 40	75,5 - 40	75 - 40
KDN 65-250 / 250		83 - 40									83 - 40	82,5 - 40	82,5 - 40
KDN 65-250 / 263		93 - 40									92,5 - 40	92 - 40	92 - 40
KDN 65-315 / 260		94 - 30											
KDN 65-315 / 275	H (m)	105 - 30											
KDN 65-315 / 290		117 - 30											
KDN 65-315 / 305	129 - 40												
KDN 65-315 / 320	143 - 50												
KDN 80-160 / 147 / 127		23 - 15											
KDN 80-160 / 153 / 136		25,5 - 15											
KDN 80-160 / 153		29,2 - 20											
KDN 80-160 / 161		32,8 - 20											
KDN 80-160 / 169		36,5 - 25											
KDN 80-160 / 177		40 - 25											
KDN 80-200 / 170		36,5 - 25											
KDN 80-200 / 180		41 - 25											
KDN 80-200 / 190		45,5 - 30											
KDN 80-200 / 200		51 - 40											
KDN 80-200 / 210		56 - 40											
KDN 80-200 / 222		63,5 - 50											
KDN 80-250 / 220		62 - 50											
KDN 80-250 / 230		68 - 50											
KDN 80-250 / 240		75,5 - 60											
KDN 80-250 / 250		82,5 - 60											
KDN 80-250 / 260		90 - 75											
KDN 80-250 / 270		98 - 75											
KDN 80-315 / 275		104 - 40											
KDN 80-315 / 290		116 - 40											
KDN 80-315 / 305		124 - 50											
KDN 80-315 / 320		141 - 60											
KDN 80-315 / 334		153 - 75											



66	72	78	84	90	102	114	120	150	180	210	240	270	300	330	360	390	420
1100	1200	1300	1400	1500	1700	1900	2000	2500	3000	3500	4000	4500	5000	5500	6000	6500	7000
13,1-75	12,8-75	12,2-75	11,9-75	11,4-75	10,2-75	8,7-75	8-75										
14,9-75	14,4-75	13,9-75	13,4-75	13-75	11,5-10	10,3-10	9,4-10										
16,8-75	16,4-75	16-75	15,4-10	15-10	13,5-10	12,2-10	11,4-10										
18,9-10	18,5-10	18-10	17,5-10	17-10	15,7-10	14,2-10	13,2-15										
21-10	20,5-10	20,1-10	19,6-10	19,2-10	18-15	16,5-15	15,6-15										
23-10	22,8-10	22,3-15	22-15	21,4-15	20,3-15	18,9-15	18-15	13,8-15									
25-15	24,6-15	24,3-15	24-15	23,4-15	22,5-15	21,1-15	22,2-15	16-15									
21,3-10	20,5-10	19,7-10	19-10	18-10	16-10												
24,6-10	24-10	23,5-15	22,7-15	22-15	20-15	17,8-15	16,5-15										
28,5-15	28-15	27,5-15	26,6-15	26-15	24-15	22-15	21-15										
32-15	31,7-15	31,3-15	30,5-15	30-15	28,5-20	26,5-20	25,5-20										
36-15	35,7-15	35,3-20	34,7-20	34-20	32,7-20	31-20	30-20										
40-20	39,8-20	39,5-20	39-20	38,5-20	37,2-20	35,5-25	34,7-25	28,5-25									
36,5-15	36-15	35-15	34-15	32,5-15	30-20	27-20	25-20										
42-15	41,5-15	41-20	40-20	39-20	36,5-20	34-25	32-25										
48-20	47,5-20	47-20	46-20	45-25	43-25	40,5-25	39-30										
54-20	53,5-25	53-25	52,5-25	52-25	50-30	48-30	46,5-30										
60-25	59,5-25	59-30	58,5-30	58-30	56,5-40	54,5-40	53,5-40										
66-30	65,5-30	65-30	65-40	64,5-40	63-40	61-40	60-40	52,5-50									
61-30	60-30	59,5-30	58-30	57-30	54-40	50,5-40	48-40										
68-30	67-40	66-40	65-40	64-40	63-40	58,5-40	56,5-50										
75-40	74-40	73-40	72-40	71-40	69-50	66-50	64-50										
82-40	81,5-40	81-40	80-50	79-50	76,5-50	73,5-50	72-60	60-60									
91,5-50	91,5-50	91-50	90-50	89,5-50	87,5-60	85-60	83-60	72,5-75									
	92-40	91-50	90-50	88-50	87-50	83-60	80-60	66-60									
	104-50	103-50	102-50	101-60	99-60	96-60	95-60	83-75									
	115-60	115-60	114,5-60	114-60	112-60	109,5-75	109-75	99,5-100	86-100								
	128-75	128-75	127,5-75	127-75	126-100	124-100	123-100	116-100	103,5-125	88-125							
	141-75	141-100	140,5-100	140-100	139,5-100	138-100	137-100	131,5-125	122,5-125	109-150							
				21,5-15	20,7-15	20-15	19,5-15	17-15	14,5-20	11,8-20	8,8-20						
				24,5-15	23,8-15	23-15	22,5-20	20,2-20	17,5-20	15-20	11,8-20						
				28-20	27,3-20	26,5-20	26-20	23,5-20	20,7-25	16,5-25	14,5-25						
				32-20	31,5-20	30,5-20	30-25	27,8-25	25-25	21,5-30	18,5-30						
				35,7-25	35,2-25	34,5-25	34,2-25	32-25	29,5-30	26,5-30	22,6-40	18,5-40					
				39,5-25	39,2-25	38,7-30	38,5-30	37-30	34,8-40	31,8-40	27,8-40	23-40					
				36-25	35,5-25	34,5-25	34-25	31-30	27-30	21,5-30							
				41-25	40,5-25	40-25	39,5-30	37-40	33-40	27,5-40							
				46,5-30	46-30	45,5-40	45-40	42-40	39-40	34-50							
				52-40	51,5-40	51,2-40	51-40	49-50	46,5-50	41-50	35-60						
				58-40	57,5-40	57,2-40	57-50	55-50	52-60	48-60	43-60						
				65-50	65-50	64,5-50	64-50	63-60	60-60	56,5-60	51,5-75	45-75					
				65,5-50	65-50	64-50	63-50	60-60	55,5-60	49-60							
				72-50	71,5-50	71-50	70-60	67-60	63-75	57-75	50-75						
				79-60	78-60	78-60	77-60	74,5-75	71-75	65,5-75	58,5-100						
				85-60	85-60	85-75	84,5-75	82-75	78,5-100	74-100	67,5-100	60,5-100					
				92,5-75	92,5-75	92-75	92-75	89,5-100	86,5-100	82-100	77-100	70-125	61,5-125				
				99-75	99-75	98,5-75	98,5-100	97-100	94-100	89-100	84-125	77-125	69-125				
					105-75	104-75	104-75	101-100	96-100	88-100	77-100						
					117-75	116,5-100	116-100	114-100	111-100	104-125	96,5-125	85-125					
					130-100	129,5-100	129,5-100	127,5-125	124,5-125	120,5-125	113,5-150						
					144-100	143,5-100	143,5-125	142-125	139-150								
					155-125	156-125	156-125	155,5-150									

2.900 r.p.m.



MODELO	Q m ³ /h l/min	0	120	150	180	210	240	270	300	330	360	420
		0	2000	2500	3000	3500	4000	4500	5000	5500	6000	6000
KDN 100-200 / 180		40 - 40		40 - 40	38 - 40	36 - 40	33 - 40	30,5 - 50	28 - 50	25 - 50		
KDN 100-200 / 190		46,5 - 50		45 - 50	44 - 50	42 - 50	39 - 50	37 - 50	34,5 - 60	31 - 60	28 - 60	
KDN 100-200 / 200		51,5 - 50		51 - 50	50 - 50	48,5 - 60	46 - 60	44 - 60	42 - 75	39 - 75	35 - 75	
KDN 100-200 / 210		57,5 - 60		57 - 60	56 - 60	55 - 75	53 - 75	51 - 75	49 - 75	46 - 100	43 - 100	36 - 100
KDN 100-200 / 219		64 - 75		62,5 - 75	62 - 75	61 - 75	60 - 75	58 - 100	56 - 100	53 - 100	50 - 100	43 - 100
KDN 100-250 / 220	H (m)	61 - 60		61,5 - 60	59,5 - 60	57 - 75	54 - 75	50,5 - 100	46,5 - 100	42 - 100		
KDN 100-250 / 230		67 - 75		68 - 75	66,5 - 75	64 - 75	61 - 100	58 - 100	54 - 100	49 - 100	44 - 100	
KDN 100-250 / 240		73 - 75		76 - 75	74 - 75	71,5 - 100	69 - 100	66 - 100	63 - 100	58,5 - 125	53 - 125	
KDN 100-250 / 250		80 - 100		83 - 100	81,5 - 100	79,5 - 100	77 - 100	74 - 125	71 - 125	67 - 125	62,5 - 150	
KDN 100-250 / 260		88 - 100		90,5 - 100	89,5 - 100	88 - 100	86 - 125	83 - 125	79,5 - 125	76 - 150	71,5 - 150	

N.º negro: **Altura m.c.a.** - N.º verde: **Potencia Nominal en CV**
 N.º black: **Height w.c.m.** - N.º Green: **Nominal Power HP**

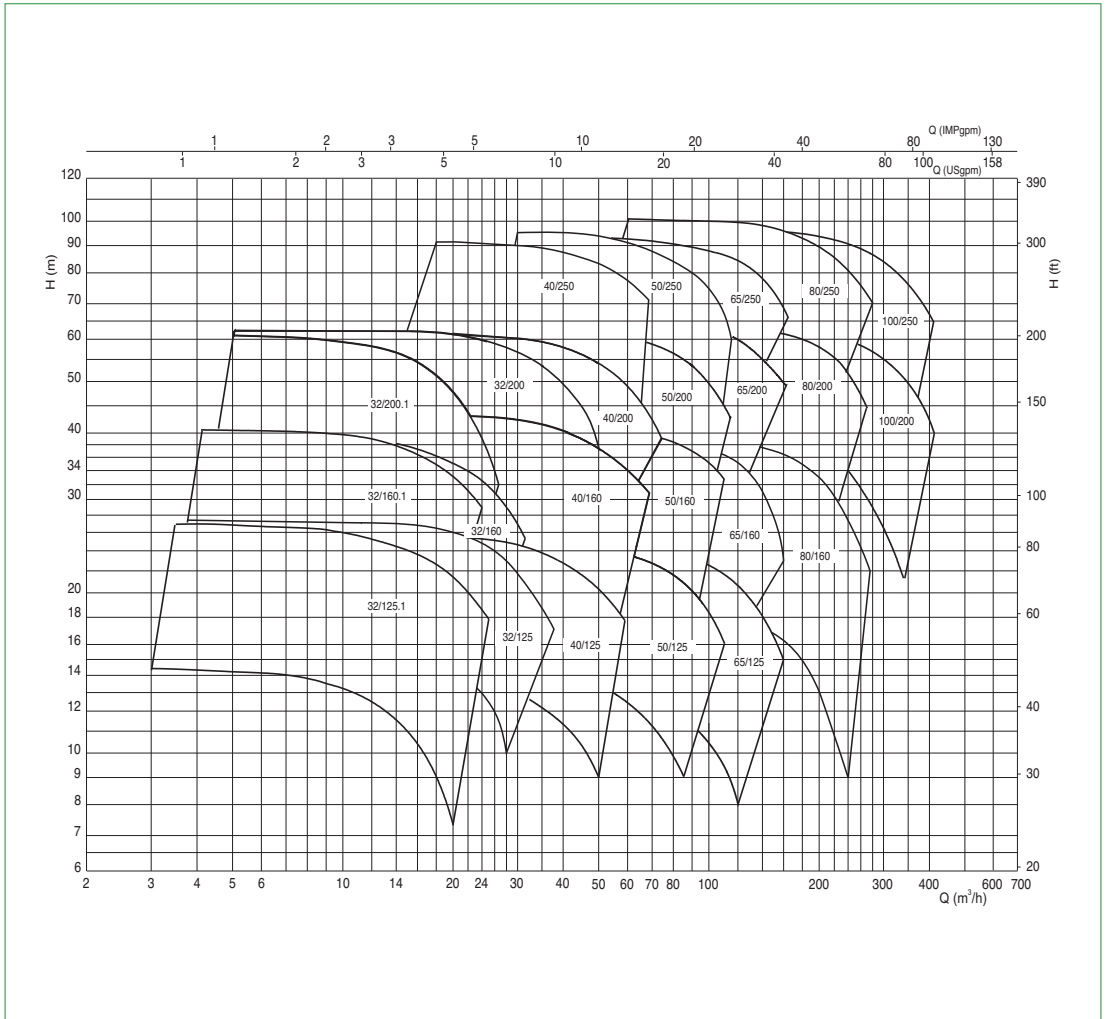

MODELO	Q m³/h l/min	0	3	6	12	18	24	30	36	42	48	54
		0	50	100	200	300	400	500	500	700	800	900
KDN 32-125.1 / 105	H (m)	3,4-0,5	3,4-0,5	3,1-0,5								
KDN 32-125.1 / 110		3,9-0,5	3,8-0,5	3,5-0,5								
KDN 32-125.1 / 115		4,25-0,5	4,2-0,5	3,9-0,5								
KDN 32-125.1 / 120		4,7-0,5	4,6-0,5	4,3-0,5								
KDN 32-125.1 / 125		5,1-0,5	5,1-0,5	4,8-0,5								
KDN 32-125.1 / 130		5,6-0,5	5,6-0,5	5,3-0,5								
KDN 32-125.1 / 135		6,1-0,5	6-0,5	5,8-0,5	4,4-0,5							
KDN 32-125.1 / 140		6,6-0,5	6,6-0,5	6,4-0,5	5,1-0,75							
KDN 32-125 / 115		4,3-0,5		4,1-0,5	3,2-0,5							
KDN 32-125 / 120		4,75-0,5		4,6-0,5	3,75-0,5							
KDN 32-125 / 125		5,2-0,5		5,05-0,5	4,2-0,5							
KDN 32-125 / 130		5,7-0,5		5,5-0,5	4,8-0,5							
KDN 32-125 / 135		6,2-0,5		6-0,5	5,3-0,75	3,65-0,75						
KDN 32-125 / 142		6,9-0,5		6,75-0,5	6,15-0,75	4,5-0,75						
KDN 32-160.1 / 137		6-0,5	5,6-0,5	4,6-0,5								
KDN 32-160.1 / 145		6,7-0,5	6,4-0,5	5,5-0,5								
KDN 32-160.1 / 153		7,5-0,5	7,1-0,5	6,4-0,5								
KDN 32-160.1 / 161		8,2-0,5	7,9-0,5	7,3-0,5								
KDN 32-160.1 / 169		9,1-0,5	8,7-0,5	8,1-0,75	5,5-0,75							
KDN 32-160.1 / 177		10,2-0,5	9,8-0,5	9,2-0,75	6,6-1							
KDN 32-160 / 137		5,9-0,5		5,6-0,5	4,4-0,5							
KDN 32-160 / 145		6,7-0,5		6,5-0,5	5,3-0,75							
KDN 32-160 / 153		7,6-0,5		7,4-0,5	6,25-0,75							
KDN 32-160 / 161		8,5-0,75		8,25-0,75	7,25-1	8,7-1						
KDN 32-160 / 169		9,5-0,75		9,3-0,75	8,4-1	6,6-1,5						
KDN 32-160 / 177		10,5-1		10,4-1	9,6-1,5	7,8-1,5						
KDN 32-200.1 / 170		9,4-0,5	8,8-0,5	7,6-0,5								
KDN 32-200.1 / 180		10,5-0,5	10-0,5	9-0,75								
KDN 32-200.1 / 190		11,6-0,75	11,2-0,75	10,3-0,75								
KDN 32-200.1 / 200		12,9-0,75	12,5-0,75	11,6-1	7,6-1,5							
KDN 32-200.1 / 207		13,9-0,75	13,5-0,75	12,6-1	8,8-1,5							
KDN 32-200 / 170		8,6-0,75		8,2-0,75	6,7-0,75							
KDN 32-200 / 180		9,9-0,75		9,6-0,75	8,2-1							
KDN 32-200 / 190		11,2-0,75		10,9-0,75	9,7-1	7-1,5						
KDN 32-200 / 200		12,6-1		12,3-1	11,1-1,5	8,7-1,5						
KDN 32-200 / 210		14,3-1		14-1	13,1-1,5	10,7-2						
KDN 32-200 / 219		15,7-1,5		15,4-1,5	14,8-2	13-2	9,8-3					
KDN 40-125 / 115		4,2-0,5		4,1-0,5	3,8-0,5	3,2-0,5	2,4-0,5					
KDN 40-125 / 120		4,6-0,5		4,5-0,5	4,2-0,5	3,7-0,75	2,9-0,75					
KDN 40-125 / 125		5,1-0,5		4,9-0,5	4,7-0,75	4,1-0,75	3,3-0,75					
KDN 40-125 / 130	5,5-0,5		5,4-0,5	5,2-0,75	4,7-0,75	3,9-0,75						
KDN 40-125 / 135	6-0,5		5,9-0,5	5,8-0,75	5,3-0,75	4,6-1						
KDN 40-125 / 142	6,7-0,75		6,6-0,75	6,5-0,75	6-1	5,3-1	4,1-1,5					
KDN 40-160 / 137	5,9-0,5		6-0,5	5,7-0,75	5-0,75	3,7-0,75						
KDN 40-160 / 145	6,7-0,5		6,8-0,5	6,6-0,75	6-1	4,8-1						
KDN 40-160 / 153	7,6-0,75		7,8-0,75	7,6-1	7-1,5	6-1,5						
KDN 40-160 / 161	8,5-1		8,7-1	8,6-1,5	8-1,5	7,1-1,5	5,6-1,5					
KDN 40-160 / 169	9,6-1		9,7-1	9,6-1,5	9,1-1,5	8,3-1,5	7-1,5					
KDN 40-160 / 177	10,7-1		10,7-1	10,6-1,5	10,2-1,5	9,5-2	8,3-2					
KDN 40-200 / 170	8,4-0,75		8,75-0,75	8,4-1	7,4-1,5	5,7-1,5						
KDN 40-200 / 180	9,7-0,75		10-0,75	9,7-1	8,8-1,5	7,2-1,5						
KDN 40-200 / 190	10,9-1		11,1-1	11-1,5	10,2-1,5	8,8-2	6,8-2					
KDN 40-200 / 200	12,2-1		12,5-1	12,4-1,5	11,7-2	10,4-2	8,6-2					
KDN 40-200 / 210	13,6-1,5		13,9-1,5	13,9-1,5	13,2-2	12,1-3	10,6-3					
KDN 40-200 / 219	15-1,5		15,2-1,5	15,2-2	14,7-3	13,8-3	12,4-3	10,4-3				
KDN 40-250 / 220	15,8-2			15,6-2	14,8-3	13,6-3	12-3					
KDN 40-250 / 230	17,4-2				17,2-2	16,5-3	15,3-3	13,7-4				
KDN 40-250 / 240	19-3				19-3	18,2-3	17-4	15,5-4				
KDN 40-250 / 250	20,7-3				20,6-3	20-4	18,9-4	17,5-5,5				
KDN 40-250 / 260	22,7-3				22,6-3	22,1-4	21-5,5	19,5-5,5				

1.450 r.p.m.



MODELO	Q m³/h l/min	H (m)											
		0	3	6	12	18	24	30	36	42	48	54	60
		0	50	100	200	300	400	500	600	700	800	900	1000
KDN 50-125 / 115		4,2-0,5			4,1-0,5	3,9-0,5	3,6-0,75	3,3-0,75	2,9-0,75	2,3-0,75			
KDN 50-125 / 120		4,6-0,5			4,4-0,5	4,3-0,75	4-0,75	3,7-1	3,3-1	2,8-1			
KDN 50-125 / 125		5-0,75			4,9-0,75	4,7-0,75	4,5-0,75	4,2-1	4,2-1	3,7-1	3,3-1,5		
KDN 50-125 / 130		5,6-0,75			5,4-0,75	5,2-1	5-1	4,7-1,5	4,2-1,5	3,8-1,5	3,2-1,5		
KDN 50-125 / 135		6-1			5,8-1	5,7-1	5,5-1,5	5,2-1,5	4,8-1,5	4,3-1,5	3,8-1,5		
KDN 50-125 / 139		6,3-1			6,9-1	6,1-1,5	5,9-1,5	5,6-1,5	5,2-1,5	4,8-1,5	4,2-1,5		
KDN 50-125 / 144		6,7-1			6,7-1	6,6-1,5	6,4-1,5	6,2-1,5	5,8-1,5	5,3-1,5	4,8-1,5	4,1-1,5	
KDN 50-160 / 137		6,05-0,75			6,1-0,75	5,95-0,75	5,7-1	5,3-1	4,8-1,5	4,2-1,5			
KDN 50-160 / 145		6,8-0,75			6,9-0,75	6,85-1	6,6-1	6,2-1,5	5,8-1,5	5,1-1,5			
KDN 50-160 / 153		7,6-1			7,8-1	7,75-1,5	7,5-1,5	7,2-1,5	6,7-2	6,2-2			
KDN 50-160 / 161		8,4-1			8,6-1	8,65-1,5	8,45-1,5	8,2-2	7,7-2	7,2-2			
KDN 50-160 / 169		9,4-1,5			9,6-1,5	9,6-2	9,45-2	9,2-2	8,8-3	8,3-3			
KDN 50-160 / 177		10,4-1,5			10,5-1,5	10,6-2	10,5-2	10,2-3	9,95-3	9,4-3			
KDN 50-200 / 170		9,5-1,5			9,6-1,5	9,4-1,5	8,8-1,5	8-2	6,85-2				
KDN 50-200 / 180		10,6-1,5			10,8-1,5	10,6-1,5	10,2-2	9,5-3	8,6-3	7,3-3			
KDN 50-200 / 190		11,8-1,5			12-1,5	11,9-2	11,5-3	10,8-3	10,1-3	8,9-3			
KDN 50-200 / 200		13,1-2			13,4-2	13,3-3	12,9-3	12,3-3	11,6-4	10,6-4	9,4-4		
KDN 50-200 / 210		14,6-2			14,8-2	14,8-3	14,5-3	13,9-4	13,2-4	12,2-4	11-4		
KDN 50-200 / 219		16-3			16,2-3	16,2-3	15,9-3	15,4-4	14,2-4	13,8-4	12,7-5,5	11,4-5,5	
KDN 50-250 / 220		16-3			16,3-3	16,1-3	15,5-3	14,9-4	13,8-4	12,4-4	10,5-4		
KDN 50-250 / 230		17,4-3			17,9-3	17,8-3	17,2-4	16,5-4	15,5-4	14,2-5,5	12,6-5,5	10,3-5,5	
KDN 50-250 / 240		19-3			19,5-3	19,5-4	19-4	18,2-5,5	17,4-5,5	16,2-5,5	14,7-7,5	12,4-7,5	
KDN 50-250 / 250		20,8-4			21,3-4	21,3-4	20,9-4	20,1-5,5	19,5-5,5	18,1-7,5	17-7,5	14,8-7,5	
KDN 50-250 / 263		23-4			23,5-4	23,5-4	23,2-5,5	22,5-5,5	21,7-7,5	20,6-7,5	19,4-7,5	17,5-7,5	
KDN 65-125 / 120 / 110		3,75-0,75					3,5-0,75	3,3-0,75	3,2-1	2,9-1	2,7-1	2,3-1	1,9-1
KDN 65-125 / 120		4,25-1					3,9-1	3,8-1	3,6-1	3,3-1	3,1-1,5	2,7-1,5	2,3-1,5
KDN 65-125 / 125		4,7-1					4,4-1	4,25-1	4,1-1,5	3,8-1,5	3,6-1,5	3,25-1,5	2,8-1,5
KDN 65-125 / 130		5,1-1					4,9-1	4,75-1,5	4,6-1,5	4,3-1,5	4,1-1,5	3,8-1,5	3,3-1,5
KDN 65-125 / 135		5,6-1,5					5,4-1,5	5,3-1,5	5,2-1,5	4,9-1,5	4,7-2	4,3-2	3,9-2
KDN 65-125 / 140		6-1,5					5,9-1,5	5,8-1,5	5,7-1,5	5,5-1,5	5,2-2	4,9-2	4,5-2
KDN 65-125 / 144		6,5-1,5					6,35-1,5	6,25-1,5	6,2-2	5,9-2	5,7-2	5,4-2	5-2
KDN 65-160 / 137		5,8-1					5,7-1	5,4-1	5,2-1,5	4,75-1,5	4,3-1,5	3,7-1,5	
KDN 65-160 / 145		6,5-1,5					6,5-1,5	6,3-1,5	6-1,5	5,7-1,5	5,3-2	4,75-2	4,1-2
KDN 65-160 / 153		7,3-1,5					7,4-1,5	7,2-1,5	6,9-1,5	6,7-2	6,3-2	5,8-2	5,2-2
KDN 65-160 / 161		8,2-2					8,25-2	8,15-2	7,9-2	7,7-2	7,3-3	6,85-3	6,3-3
KDN 65-160 / 169		9,1-2					9,2-2	9,1-2	8,9-3	8,7-3	8,4-3	8-3	7,6-3
KDN 65-160 / 177		10-3					10,2-3	10,1-3	9,9-3	9,7-3	9,45-3	9,1-3	8,7-4
KDN 65-200 / 170		9,4-2				9,7-2	9,6-2	9,4-2	9-3	8,5-3	7,9-3	7,1-3	6,5-3
KDN 65-200 / 180		10,5-2				10,9-2	10,4-2	10,6-3	10,4-3	10-3	9,5-4	8,8-4	8,1-4
KDN 65-200 / 190		12,1-3				12,3-3	12,4-3	12,2-3	11,9-4	11,6-4	11,1-4	10,5-4	9,8-4
KDN 65-200 / 200		13,4-3				13,6-3	13,7-3	13,7-4	13,5-4	13,2-4	12,8-4	12,3-5,5	11,6-5,5
KDN 65-200 / 210		14,8-4				15-4	15,1-4	15-4	14,9-4	14,7-5,5	14,3-5,5	13,8-5,5	13,4-5,5
KDN 65-200 / 219		16,3-4				16,5-4	16,6-4	16,5-4	16,4-4	16,2-5,5	16-5,5	15,6-5,5	15-7,5
KDN 65-250 / 220		15,8-4				15,8-4	15,5-4	15,1-4	14,5-5,5	14-5,5	13,2-5,5	12-5,5	
KDN 65-250 / 230		17,4-4				17,4-4	17,2-4	16,8-5,5	16,3-5,5	15,7-5,5	15-7,5	14,1-7,5	
KDN 65-250 / 240		19-5,5				19-5,5	18,9-5,5	18,5-5,5	18,1-7,5	17,5-7,5	16,8-7,5	16-7,5	
KDN 65-250 / 250		20,7-5,5				20,7-5,5	20,6-5,5	20,4-7,5	20-7,5	19,5-7,5	18,8-7,5	18-7,5	
KDN 65-250 / 263		23,2-7,5				23-7,5	23-7,5	22,9-7,5	22,5-7,5	22,2-7,5	21,6-7,5	20,8-10	
KDN 65-315 / 260		22,2-7,5				22,2-7,5	22,1-7,5	22-7,5	21,5-7,5	21-10	20,5-10	20-10	
KDN 65-315 / 275		25,1-7,5				25,1-7,5	25-7,5	24,8-7,5	24,6-10	24,1-10	23,5-10	23-10	
KDN 65-315 / 290		28,1-7,5				28,1-7,5	28,1-7,5	28-10	27,8-10	27,3-10	27-10	26,5-15	
KDN 65-315 / 305		31,8-10				31,8-10	31,8-10	31,7-10	31,5-10	31,2-15	30,8-15	30,4-15	
KDN 65-315 / 320		35,7-10				35,4-10	35,3-10	35,2-15	35,1-15	35-15	34,8-15	34,5-15	

MODELO	Q m³/h l/min	0	3	6	12	18	24	30	36	42	48	54	60
		0	50	100	200	300	400	500	600	700	800	900	1000
KDN 80-160 / 147 / 127	5,7-2									5,4-2	5,25-2	5,05-2	4,8-2
KDN 80-160 / 153 / 136	6,4-3									6,2-3	6,05-3	5,85-3	5,7-3
KDN 80-160 / 153	7,3-3									7,1-3	6,9-3	6,7-3	6,5-3
KDN 80-160 / 161	8,2-3									8-3	7,9-3	7,75-3	7,5-3
KDN 80-160 / 169	9,1-4									9-4	8,85-4	8,7-4	8,6-4
KDN 80-160 / 177	10-4									9,9-4	9,85-4	9,8-4	9,7-4
KDN 80-200 / 170	9,2-4									9,1-4	9-4	8,7-4	8,5-4
KDN 80-200 / 180	10,3-4									10,4-4	10,2-4	10-4	9,9-4
KDN 80-200 / 190	11,4-4									11,7-4	11,6-4	11,5-5,5	11,3-5,5
KDN 80-200 / 200	12,7-5,5									13-5,5	13-5,5	12,8-7,5	12,7-7,5
KDN 80-200 / 210	14,1-5,5									14,5-5,5	14,4-5,5	14,4-7,5	14,2-7,5
KDN 80-200 / 222	15,9-7,5									16,2-7,5	16,2-7,5	16,1-7,5	16,1-7,5
KDN 80-250 / 220	16-7,5									16,4-7,5	16,2-7,5	16,1-7,5	15,9-7,5
KDN 80-250 / 230	17,3-7,5									18-7,5	17,9-7,5	17,7-7,5	17,5-7,5
KDN 80-250 / 240	19-7,5									19,7-7,5	19,6-7,5	19,5-7,5	19,3-10
KDN 80-250 / 250	20,6-10									21,4-10	21,3-10	21,2-10	21-10
KDN 80-250 / 260	22,6-10									23,1-10	23-10	22,9-10	22,8-10
KDN 80-250 / 270	24,5-10									24,8-10	24,7-10	24,6-10	24,5-10
KDN 80-315 / 275	24,9-15										25,5-15	25,4-15	25,3-15
KDN 80-315 / 290	28-15										28,8-15	28,6-15	28,3-15
KDN 80-315 / 305	31,4-15										32,1-15	32-15	32-15
KDN 80-315 / 320	34,8-20										35,8-20	35,9-20	35,8-20
KDN 80-315 / 334	38,3-20										39-20	39,1-20	39,1-20
KDN 100-200 / 180	10,2-7,5												10,1-7,5
KDN 100-200 / 190	11,6-7,5												11,5-7,5
KDN 100-200 / 200	12,9-7,5												12,8-7,5
KDN 100-200 / 210	14,3-10												14,2-10
KDN 100-200 / 219	16-10												15,7-10
KDN 100-250 / 220	15,2-10												15,6-10
KDN 100-250 / 230	16,9-10												17,4-10
KDN 100-250 / 240	18,5-15												19,1-15
KDN 100-250 / 250	20,1-15												20,7-15
KDN 100-250 / 260	22,3-15												22,7-15
KDN 100-250 / 270	24,3-15												24,6-15
KDN 100-315 / 275	25-15												25,5-15
KDN 100-315 / 290	28-20												28,5-20
KDN 100-315 / 305	31,2-20												31,8-20
KDN 100-315 / 320	34,5-25												35-25
KDN 100-315 / 334	38,1-25												38,1-25
KDN 125-250 / 220	15-15												
KDN 125-250 / 230	16,7-15												
KDN 125-250 / 240	18,2-20												
KDN 125-250 / 250	19,9-20												
KDN 125-250 / 260	21,8-25												
KDN 125-250 / 269	24-25												
KDN 150-200 / 210 / 170	9,2-15												
KDN 150-200 / 218 / 182	10,5-15												
KDN 150-200 / 218 / 200	11,6-15												
KDN 150-200 / 218	12,9-20												
KDN 150-200 / 224	13,8-20												

N.º negro: **Altura m.c.a.** - N.º verde: **Potencia Nominal en CV**
 N.º black: **Height w.c.m.** - N.º Green: **Nominal Power HP**



	66	72	78	84	90	102	114	120	150	180	210	240	270	300	330	360	390	420
	1100	1200	1300	1400	1500	1700	1900	2000	2500	3000	3500	4000	4500	5000	5500	6000	6500	7000
	4,6-2	4,35-3	4,15-3	3,85-3	3,6-3	3,1-3	2,5-3	2,2-3										
	5,4-3	5,15-3	4,8-3	4,65-3	4,4-3	3,85-3	3,3-3	3-3										
	6,3-3	6-3	5,75-3	5,4-3	5,2-3	4,55-4	3,9-4	3,6-4										
	7,3-3	7,05-4	6,8-4	6,5-4	6,25-4	5,6-4	4,9-4	4,6-4										
	8,35-4	8,1-4	7,85-4	7,6-4	7,3-4	6,75-5,5	6-5,5	5,7-5,5										
	9,5-4	9,3-5,5	9,1-5,5	8,85-5,5	8,7-5,5	8,1-5,5	7,25-5,5	6,9-5,5										
	8,2-4	7,8-4	7,5-4	7,1-4	6,7-5,5	5,6-5,5												
	9,6-4	9,2-5,5	9-5,5	8,6-5,5	8,2-5,5	7,2-5,5												
	11-5,5	10,7-5,5	10,5-5,5	10,1-7,5	9,8-7,5	8,7-7,5	6,8-7,5											
	12,5-7,5	12,3-7,5	12-7,5	11,6-7,5	11,4-7,5	10,5-7,5	9,4-7,5	8,8-7,5										
	14,1-7,5	13,9-7,5	13,7-7,5	13,3-7,5	13,1-7,5	12,1-7,5	11,2-10	10,6-10										
	16-7,5	15,7-7,5	15,6-7,5	15,3-7,5	15-10	14,3-10	13,4-10	12,8-10										
	15,5-7,5	15,2-7,5	14,9-7,5	14,5-7,5	13,9-10	12,8-10												
	17,2-7,5	16,9-10	16,5-10	16-10	15,5-10	14,3-10	12,4-10											
	19-10	18,7-10	18,4-10	18-10	17,6-10	16,6-15	15,3-15	14,6-15										
	20,8-10	20,6-10	20,3-10	19,9-15	19,6-15	18,6-15	17,4-15	16,8-15										
	22,6-10	22,4-15	22,1-15	21,8-15	21,4-15	20,6-15	19,6-15	19-15	15,1-15									
	24,4-15	24,3-15	24,1-15	23,7-15	23,3-15	22,4-15	21,4-15	20,7-15	16,3-20									
	25,1-15	25-15	24,8-15	24,3-15	24-15	23-15	21,4-20	20,5-20										
	28,3-15	28,1-15	28-15	27,5-15	27,4-15	26,5-20	25-20	24,6-20	19,1-20									
	32-20	31,8-20	31,5-20	31,2-20	30,9-20	30-20	29-25	28,5-25	24-25									
	35,6-20	35,4-20	35-20	34,9-20	34,7-20	34-20	33,2-25	32,8-25	28,8-30									
	39-20	38,8-20	38,6-20	38,5-20	38,3-25	37,9-25	37-25	36,9-30	33,1-30	28-40								
	10,1-7,5	10-7,5	9,9-7,5	9,7-7,5	9,5-7,5	9,1-7,5	8,5-7,5	8,3-7,5	7-7,5	5,4-7,5								
	11,4-7,5	11,3-7,5	11,2-7,5	11,1-7,5	11-7,5	10,5-7,5	10,1-7,5	10-7,5	8,6-10	7-10								
	12,8-7,5	12,8-7,5	12,7-7,5	12,6-10	12,5-10	12,2-10	11,8-10	11,6-10	10,4-10	8,8-10								
	14,2-10	14,2-10	14,2-10	14,1-10	14-10	13,8-10	13,5-10	13,3-10	12,3-15	10,7-15	9-15							
	15,7-10	15,6-10	15,6-10	15,5-10	15,5-10	15,3-10	15,1-15	15-15	14-15	12,5-15	10,8-15							
	15,5-10	15,3-10	15,2-10	15-10	14,8-10	14,3-10	13,7-15	13,4-15	11,4-15									
	17,3-10	17,2-10	17-10	16,8-15	16,6-15	16,2-15	15,7-15	15,3-15	13,6-15	11,1-15								
	19-15	18,9-15	18,8-15	18,6-15	18,5-15	18,2-15	17,6-15	17,4-15	15,7-20	13,3-20								
	20,7-15	20,6-15	20,5-15	20,4-15	20,3-15	20-15	19,4-15	19,2-15	17,6-20	15,4-20								
	22,7-15	22,6-15	22,5-15	22,5-15	22,4-15	22,1-15	21,6-15	21,4-20	19,8-20	17,7-20	15,1-20							
	24,6-15	24,6-15	24,6-15	24,5-15	24,4-15	24,1-20	23,7-20	23,5-20	22,1-20	20,1-25	17,3-25							
	25,4-15	25,3-15	25,2-15	25,1-15	25-15	24,7-20	24,4-20	24-20	22-20	19-25								
	28,5-20	28,5-20	28,4-20	28,3-20	28,2-20	28-20	27,7-20	27-20	25,5-25	23-25								
	31,8-20	31,8-20	31,7-20	31,6-20	31,5-20	31,2-25	30,8-25	30,5-25	29-30	27-30	24-40							
	35-25	35-25	35-25	35-25	35-25	34,8-25	34,5-25	34,2-25	33-30	31-40	28,1-40							
	38,1-25	38,1-25	38,1-25	38-25	38-25	37,7-30	37,5-30	37,3-30	36,5-40	34,8-40	32-40	28,8-40						
						15,5-15	15,5-15	15,4-15	14,8-15	14-15	13-15	11,8-20	10,5-20	9,2-20				
						17,1-15	17-15	17-15	16,5-15	15,8-20	14,8-20	13,8-20	12,5-20	12,3-20	9,5-20			
						18,5-20	18,5-20	18,5-20	18,2-20	17,6-20	16,8-20	15,8-20	14,5-25	13,3-25	11,6-25	10,1-25		
						20-20	20-20	20-20	19,9-20	19,5-20	18,7-25	17,8-25	16,6-25	15,5-25	14-30	12,3-30		
						22-25	22-25	22-25	21,7-25	21,3-25	20,6-25	19,9-25	18-30	17,7-30	16,3-30	14,6-30	13-30	
						23,9-25	23,9-25	23,8-25	23,6-25	23,2-25	22,7-30	22,1-30	22,2-30	20,2-40	19-40	17,5-40	15,6-40	14-40
								9,1-15	8,9-15	8,6-15	8,3-15	7,9-15	7,5-15	6,8-15	5,9-15	5,4-15		
								10,3-15	10,2-15	9,9-15	9,5-15	9,1-15	8,6-15	8,1-15	7,4-15	6,6-15		
								11,4-15	11,2-15	10,9-15	10,5-15	10,1-20	9,7-20	9,2-20	8,5-20	7,8-20	6,9-20	5,9-20
								12,6-20	12,4-20	12,1-20	11,6-20	11,1-20	10,7-20	10,2-20	9,5-20	8,8-20	8-20	7,1-20
								13,5-20	13,3-20	13-20	12,6-20	12,2-20	11,7-20	11,2-20	10,6-20	9,9-20	9,1-20	8,2-20

1.450 r.p.m.



■ Aplicaciones:

Las electrobombas de la Serie CR son especialmente adecuadas para grandes trasvases, riegos por goteo, etc. a presiones relativamente bajas.

■ Características constructivas:

Cuerpo de bomba, soporte bomba motor y turbina en fundición de alta calidad con un pretratamiento de pintura epoxi-poliéster y secado al horno para darle más durabilidad y resistencia a la oxidación, sello mecánico en cerámica carbón y eje en acero inoxidable AISI-316.

■ Motor:

Motor asíncrono normalizado, tipo cerrado y de ventilación externa, apto para trabajo continuo. Grado de protección IP-55, a 2.850 r.p.m.

Temperatura máxima del agua 95° C

Temperatura máxima ambiente 40° C

Presión máxima admitida 6 bar



■ Applications:

The electropumps of the CR Series are particularly suitable for large transfers, drip irrigation, etc. at relatively low pressures.

■ Construction:

Pump body, motor support and impeller in high strength cast iron with epoxy-polyester paint, mechanical seal in carbon ceramic and stainless steel shaft (aisi 316).

■ Motor:

Sealed, asynchronous, with external ventilation, suitable for continuous work. IP-55 protection. All motors are standard at 2,850 r.p.m.

Maximum water temperature 95° C

Maximum ambient temperature 40° C

Tipo Type	HP	KW	r.p.m.	"A"		Caudal m ³ /h / Flow m ³ /h											Ø ASP.	Ø IMP.	
						230 V	400 V	20	45	60	85	100	120	150	175	200			220
				Altura m.c.a. / Height w.c.m.															
CR 300	3	2,2	2.850	9	5,2	17,2	12,5	6,8										DN 80	DN 80
CR 400	4	3	2.850	12	6,9	20	15	10										DN 80	DN 80
CR 550	5,5	4	2.850	16,5	9,5	19	17	15	10	6								DN 125	DN 100
CR 551	5,5	4	2.850	16,5	9,5	17,2	15,5	14,7	12,5	11	8							DN 125	DN 100
CR 750*	7,5	5,5	2.850	21,7	12,5	19	18,7	18	16,5	15	12,8	8						DN 125	DN 100
CR 1000*	10	7,5	2.850	-	15,5	23,8	22,5	21,5	19,5	18	16	12	8					DN 125	DN 100
CR 1250*	12,5	9,2	2.850	-	19	24,2	23,2	22,5	20,8	19,5	17,8	14,5	11	7				DN 125	DN 100
CR 1500*	15	11	2.850	-	23	27	25,7	24,8	23	21,5	19,7	16,5	13,5	10	7			DN 125	DN 100

En los modelos de 3 y 4 CV recomendamos la instalación con tubo de 90 mm. (For 3-4 HP we recommend minimum 90 mm. pipe)

Centrifugas Rodete Abierto

Serie "CRA"

■ Aplicaciones:

La Serie CR son bombas centrifugas equipadas con turbina abierta especialmente adecuadas para grandes trasvases, riegos por goteo, etc. a presiones relativamente bajas. Gracias al diseño de la turbina de tipo abierto permite trasegar líquidos moderadamente cargados sin peligro de atascamiento.

Muy adecuadas para la industria oliverera.

■ Características constructivas y motor:

Igual a Serie CR.

Bajo demanda con sello mecánico en widia.



■ Applications:

The CR Series are centrifugal pumps fitted with an open impeller and are particularly suitable for large transfers, drip irrigation, etc. at relatively low pressures. Thanks to the open design of the impeller, they are able to transfer moderately loaded liquids without any danger of blockage. **Highly suitable for the olive-growing industry.**

■ Construction:

Same as the CR Series. Widia mechanical seal to order.

Tipo Type	Potencia		"A"		Caudal m ³ /h / Flow m ³ /h									Diámetro	
	HP	KW	III 230	III 400	20	40	60	80	90	100	115	130	140	ASP. DN	IMP. DN
					Altura m.c.a. / Height w.c.m.										
CRA - 50	5,5	4	16,5	9,5	15	13	12	10	9	8	5	1		125	100
CRA - 70*	7,5	5,5	21,7	12,5	16	15	14	12	11	10	7	5	1	125	100

* Voltaje de Serie 400-690 V (bajo demanda 230-400 V)

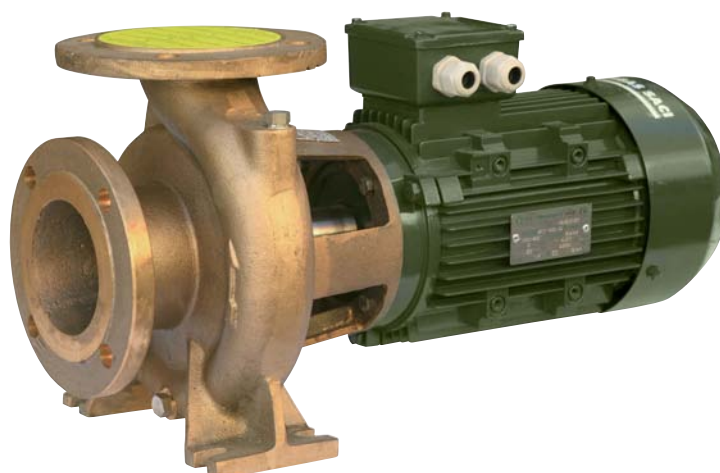

■ **Aplicaciones:**

Electrobombas centrífugas construidas íntegramente en bronce marino especialmente adecuados para grandes trasvases de líquidos especialmente agresivos o bien agua de mar a presiones relativamente bajas.

■ **Características Constructivas:**

Cuerpo bomba, soporte y turbina en bronce. Eje, tornillería y sello mecánico en acero inoxidable AISI 316. Partes de rozamiento del sello mecánico en carbón-cerámica.

■ **Motor:**

Asíncrono standard, cerrado de ventilación externa. Grado de protección IP-54. 50 Hz. Todos los motores de esta serie son a 2.850 r.p.m.

■ **Applications:**

Centrifugal electropumps built entirely in marine bronze, particularly suitable for large transfers of very aggressive liquids or sea water at relatively low pressures.

■ **Construction:**

Pump body, support and impeller in bronze. Shaft, bolts and mechanical seal in AISI 316 stainless steel. Contact parts of mechanical seal in carbon ceramic.

■ **Motor:**

Standard sealed asynchronous motor with external ventilation. IP-55 protection. 50 Hz All motors are standard at 2,850 rpm.

Tipo Type	HP	KW	r.p.m.	"A"		Caudal m ³ /h / Flow m ³ /h										Ø ASP.	Ø IMP.	
				230 V	400 V	20	45	60	85	100	120	150	175	200	220			
						Altura m.c.a. / Height w.c.m.												
CRB 300	3	2,2	2.850	9	5,2	17,2	12,5	6,8									DN 80	DN 80
CRB 400	4	3	2.850	12	6,9	20	15	10									DN 80	DN 80
CRB 550	5,5	4	2.850	16,5	9,5	19	17	15	10	6							DN 125	DN 100
CRB 551	5,5	4	2.850	16,5	9,5	17,2	15,5	14,7	12,5	11	8						DN 125	DN 100
CRB 750*	7,5	5,5	2.850	21,7	12,5	19	18,7	18	16,5	15	12,8	8					DN 125	DN 100
CRB 1000*	10	7,5	2.850	-	15,5	23,8	22,5	21,5	19,5	18	16	12	8				DN 125	DN 100
CRB 1250*	12,5	9,2	2.850	-	19	24,2	23,2	22,5	20,8	19,5	17,8	14,5	11	7			DN 125	DN 100
CRB 1500*	15	11	2.850	-	23	27	25,7	24,8	23	21,5	19,7	16,5	13,5	10	7		DN 125	DN 100

En los modelos de 3 y 4 CV recomendamos la instalación con tubo de 90 mm. (For 3-4 HP we recommend minimum 90 mm. pipe)

* Voltaje de Serie 400/690 V (bajo demanda 230/400 V) / *Standard voltage 400/690 V (under demand 230/400 V)



Kit contra bridas y tornillos disponible bajo demanda
Flanges and bolts kit available under demand

**1.450 r.p.m.
de 3 a 10 HP**

■ **Aplicaciones:**

Bomba extremadamente silenciosa dado que gira a 1.450 rpm hasta 10CV.

Bomba centrífuga que gracias al gran caudal que genera a bajas presiones, la hace idonea para muchos tipos de instalaciones, como instalaciones de refrigeración, trasvase, etc... Imposibilidad de comunicación eléctrica con el agua, ya que ninguna parte del motor tiene contacto con el líquido bombeado.

Posibilidad de trabajo con agua de mar aplicando un suplemento de sello mecánico en AISI-316.

■ **Características Constructivas:**

Cuerpo bomba, Voluta, Base y Tapa cuerpo bomba en polipropileno resistente a los productos químicos de las piscinas, y reforzado con fibra de vidrio. **Rodete de Noryl en KONTRA-4 300 y 400. Rodete de Noryl o Bronce en KONTRA-4 550, 750 y 1000. Rodete de Bronce en KONTRA-2 1250 y 1500.** Cierre me-cánico en carbón cerámica y acero inoxidable AISI 304. Tornillería en acero inoxidable AISI 304. Eje en acero inoxidable AISI 316.

■ **Motor:**

Motor asíncrono cerrado de ventilación externa. Grado de protección IP-55. Aislamiento clase F. 1.450 rpm y 2.850 rpm. Doble frecuencia 50 Hz y 60 Hz. Rodamientos engrasados de por vida, garantizando una larga duración y un trabajo silencioso.

■ **Applications:**

Extremely silent pump, at 1,450 rpm until 10HP

Centrifugal pumps with a high flow capacity generated at low pressure, makes it the ideal pumps for a lot of types of installations like cooling installations, big transfers, etc... No possible electrical contact with the water as no part of the motor is open to it.

This range is capable of working with sea water just by installing a Stainless Steel AISI-316 mechanical sea.

■ **Constructive Characteristics:**

Pump body, Volut, Base & pump body lid in polypropylene resistant to Chemicals products used in pools and reinforced with fiber glass. Strainer lid in polycarbonate with a closing system using four handles. **Noryl impeller in KONTRA-4 300 & 400. Noryl or Bronze impeller in KONTRA-4 550, 750 & 1000. Bronze impeller in KONTRA-2 1250 & 1500.** Mechanical seal in carbon-ceramic & stainless steel AISI 304. Nuts and bolts in stainless steel AISI 304. Shaft in stainless steel AISI 316.

■ **Motor:**

Standard Asynchronous motor, sealed with external ventilation. Protection IP-55. Isolation class F, 1,450 rpm y 2,850 rpm. Double frequency 50 Hz y 60 Hz. Motor bearings greased for life and selected to ensure long duration and silent working.

Tipo Type	Potencia		"A"			r.p.m.	Altura m.c.a. / Height w.c.m.											Diámetro	
	HP	KW	III	III	III		6	8	10	12	14	16	18	20	22	24	ASP	IMP	
			230	400	690		Caudal m ³ /h / Flow m ³ /h												
Kontra-4 300	3	2,2	9,4	5,3	-	1.450	63	53	43	30	16							110	110
Kontra-4 400	4	3	12,5	6,9	-	1.450	72	64	56	46	35	20						110	110
Kontra-4 550	5,5	4	15,3	8,8	-	1.450	115	96	79	52	20							110	110
Kontra-4 750	7,5	5,5	-	12	7	1.450	136	121	101	83	59	26						110	110
Kontra-4 1000	10	7,5	-	15,8	9,2	1.450	156	146	126	108	88	61	30					110	110
Kontra-2 1250	12,5	9,2	-	18,5	10,7	2.850	191	182	165	146	132	115	102	76	43			110	110
Kontra-2 1500	15	11	-	20,9	12	2.850	203	194	181	171	158	145	130	120	100	80		110	110

Serie "V-NOX 300 - 400"	32
Serie "XV-F" Inoxidable AISI 304	33
Serie "VX SS-F" Inoxidable AISI 316	36
Series "VAT 127-163-205"	38
Serie "V"	40



■ **Aplicaciones:**

Las bombas verticales multicelulares de la serie V-NOX, por su elevado rendimiento y funcionamiento EXTREMADAMENTE SILENCIOSO, son especialmente indicadas para su uso en equipos de presurización y equipos contra incendios.

■ **Características Constructivas:**

Turbinas, eje bomba, cuerpo bomba en acero inoxidable AISI 304, difusores en tecnopolímero inyectado con fibra de vidrio, contrabridas de aspiración e impulsión, base aspiración y cuerpo de impulsión en fundición GG-20 con tratamiento de pintura epoxi-poliéster interior y exterior para ofrecer mas resistencia a la oxidación. Eje apoyado sobre casquillo inferior guía en Bronce. Cierre mecánico en cerámica grafito y AISI 304.

■ **Motor:**

Motor asíncrono, cerrado de ventilación externa, apto para trabajo continuo. Grado de protección IP-55, aislamiento clase F (calentamiento "B") aptos para trabajo a través de variadores de frecuencia.

Temperatura máxima del agua: 45° C.

Temperatura máxima ambiente: 45° C.



■ **Applications:**

The multistage vertical pumps of the V-NOX series, through their high output and EXTREMELY SILENT operation, are particularly recommended for use in pressure and fire-fighting equipment both for civil and industrial use.

■ **Constructive characteristics:**

Impeller, pump shaft, pump housing in AISI 304 stainless steel, diffusers in technopolymer injected with glass fiber, suction and drive counter-flanges, suction base and drive housing in GG-20 cast iron with exterior and interior epoxi-poliéster treatment to prevent rust. Shaft supported on lower bushing, guide in Bronze. Mechanical seal in graphite ceramic and AISI 304.

■ **Motor:**

Standard asynchronous motor, sealed from external ventilation, suitable for continuous work. IP-55 protection, class F isolation (heating "B") suitable for work through frequency inverters.

Maximum water temperature: 45° C.

Maximum ambient temperature: 45° C.

Tipo Type	Potencia		"A"			Con. µF	Caudal m³/h / Flow m³/h								Diámetro		
			II 230	III 230	III 400		1,5	3	4,5	6	7	8	9	10	11	ASP.	IMP.
	HP	KW	Altura m.c.a. / Height w.c.m.														
V-NOX 303 M/T	1,2	0,9	7	4,2	2,3	40	39	37	35	32	28	24	20	14	8	11/2"	11/4"
V-NOX 304 M/T	1,5	1,1	8,2	4,8	2,5	40	51	50	46	42	37	32	26	18	12	11/2"	11/4"
V-NOX 305 M/T	2	1,5	9,5	6,1	3,5	40	65	62	58	52	46	40	32	24	14	11/2"	11/4"
V-NOX 306 T	3	2,2	-	8,5	5,1	-	77	75	70	63	56	48	38	28	16	11/2"	11/4"
V-NOX 307 T	3	2,2	-	8,5	5,1	-	90	86	79	70	65	54	42	32	18	11/2"	11/4"
V-NOX 308 T	4	3	-	11	6,6	-	103	100	92	84	74	64	52	36	21	11/2"	11/4"
V-NOX 309 T	4	3	-	11	6,6	-	117	112	104	92	83	70	56	42	23	11/2"	11/4"
V-NOX 310 T	5,5	4	-	14	8	-	129	124	116	104	92	79	64	48	26	11/2"	11/4"

Tipo Type	Potencia		"A"			Con. µF	Caudal m³/h / Flow m³/h								Diámetro		
			II 230	III 230	III 400		1,5	3	4,5	6	9	12	15	18	21	ASP.	IMP.
	HP	KW	Altura m.c.a. / Height w.c.m.														
V-NOX 403 M/T	2	1,5	9,5	6,1	3,5	40	35	34	33	32	30	28	24	19	12	11/2"	11/4"
V-NOX 404 T	3	2,2	-	8,5	5,1	-	46	45	44	43	40	36	31	24	14	11/2"	11/4"
V-NOX 405 T	4	3	-	11	6,6	-	58	57	55	54	50	46	40	31	18	11/2"	11/4"
V-NOX 406 T	4	3	-	11	6,6	-	70	69	67	65	61	56	49	37	23	11/2"	11/4"
V-NOX 407 T	5,5	4	-	14	8	-	82	81	79	77	71	65	57	45	28	11/2"	11/4"



B

■ Aplicaciones:

Las electrobombas de la serie XV-F son bombas centrífugas verticales multicelulares, no autocebantes, con bocas de aspiración e impulsión en línea, que por su elevado rendimiento las hace ideales para su uso en equipos de presión, en instalaciones industriales y en todas aquellas aplicaciones en que se requiera altas presiones con caudales moderados.

■ Características constructivas:

Turbinas, difusores, eje, camisa externa y cámaras intermedias, íntegramente en acero inoxidable AISI 304. Base aspiración-impulsión y cuerpo superior en fundición de hierro de alta resistencia. Sello mecánico en carburo de silicio/EPDM. Juntas tóricas en goma EPDM o teflón. **Incorporan un novedoso sello mecánico de tipo cartucho, que permite una fácil y rápida sustitución, sin desmontar ninguna pieza de la parte hidráulica de la bomba.**

Todas las versiones equipan bridas DIN y no incorporan contrabridas de serie:

XV-F 5	DN 32
XV-F 10	DN 40
XV-F 15 y XV-F 20	DN 50
XV-F 32	DN 65
XV-F 45	DN 80
XV-F 64 y XV-F 90	DN 100

■ Motor:

Motor asíncrono, tipo cerrado y de ventilación externa, apto para trabajo continuo. Grado de protección IP-54, aislamiento clase F, a 2.850 r.p.m.
Los modelos monofásicos a 230 V incorporan un protector térmico y condensador permanente.

Temperatura del líquido a bombear -15° C a +120° C
Temperatura máxima ambiente 40° C

■ Applications:

The electropumps of the XV-F series are multicellular vertical centrifugal pumps, non self-priming, with suction and drive in line, and their high output makes them ideal for use in pressure equipment, industrial installations and all applications requiring high pressures with moderate flows.

■ Construction:

Impellers, diffusers, shaft, external cladding and intermediate chambers entirely in AISI 304 stainless steel. Suction drive base and upper body in high strength cast iron. Silicon carbide/EPDM mechanical seal. EPDM rubber or Teflon o-rings. **Includes a new mechanical seal type cartridge, for quick and easy substitution without dismantling any piece of the hydraulic part of the pump.**

All versions are fitted with DIN flanges and do not include counter flanges as standard.

XV-F 5	DN 32
XV-F 10	DN 40
XV-F 15 y XV-F 20	DN 50
XV-F 32	DN 65
XV-F 45	DN 80
XV-F 64 y XV-F 90	DN 100

■ Motor:

Sealed asynchronous with external ventilation, suitable for continuous work. IP-55 protection, class F insulation, at 2,850 rpm. Single phase versions at 230 V includes a thermal protector and permanent capacitor.

Maximum water temperature . . . -15° C to +120° C
Maximum ambient temperature 40° C

Tipo Type	Con. µF	Potencia		"A"			Caudal m ³ /h / Flow m ³ /h								Diámetro		
		HP	KW	II 230	III 230	III 400	0	1	2	3	4	5	6	7	8	ASP.	IMP.
							Altura m.c.a. / Height w.c.m.										
XV-F 5-8	25	1,5	1,1	9,3	4,3	2,5	52	51	48	46	43	39	34	28	22	DN 32	DN 32
XV-F 5-10	45	2	1,5	12	5,9	3,4	65	64	62	60	56	51	46	40	32	DN 32	DN 32
XV-F 5-14	-	3	2,2	-	8,3	4,8	93	92	90	87	82	75	67	58	47	DN 32	DN 32
XV-F 5-16	-	3	2,2	-	8,3	4,8	108	107	103	98	92	86	77	67	54	DN 32	DN 32
XV-F 5-20	-	4	3	-	10,9	6,3	135	133	131	126	118	110	98	85	68	DN 32	DN 32
XV-F 5-29	-	5,5	4	-	13,8	8	197	196	192	185	176	164	148	128	107	DN 32	DN 32
XV-F 5-36	-	7,5	5,5	-	21,5	12,4	246	242	236	227	216	190	182	158	132	DN 32	DN 32

Tipo Type	Potencia		"A"		Caudal m ³ /h / Flow m ³ /h								Diámetro		
	HP	KW	III 230	III 400	0	4,5	6	7	8	9	10	11	12	ASP.	IMP.
					Altura m.c.a. / Height w.c.m.										
XV-F 10-6	3	2,2	8,8	5,1	60	59	58	57	53	50	46	42	37	DN 40	DN 40
XV-F 10-9	4	3	11,8	6,8	90	88	87	85	80	76	70	64	57	DN 40	DN 40
XV-F 10-10	5,5	4	16,8	9,7	101	100	98	96	91	86	79	72	64	DN 40	DN 40
XV-F 10-12	5,5	4	16,8	9,7	121	120	117	114	108	102	95	86	77	DN 40	DN 40
XV-F 10-16	7,5	5,5	21,5	12,4	162	161	156	152	145	137	128	117	104	DN 40	DN 40
XV-F 10-22	10	7,5	28	16,4	225	223	218	211	202	190	178	162	145	DN 40	DN 40

Tipo Type	Potencia		"A"		Caudal m ³ /h / Flow m ³ /h								Diámetro		
	HP	KW	III 230	III 400	0	6	10	12	14	16	18	20	22	ASP.	IMP.
					Altura m.c.a. / Height w.c.m.										
XV-F 15-5	5,5	4	16,8	9,7	68	67	64	62	58	55	51	46	40	DN 50	DN 50
XV-F 15-7	7,5	5,5	21,5	11,3	97	95	90	87	82	78	72	66	59	DN 50	DN 50
XV-F 15-9	10	7,5	28	14,7	125	122	118	113	108	102	95	86	76	DN 50	DN 50
XV-F 15-14	15	11	40	21	194	190	183	178	170	160	149	135	120	DN 50	DN 50
XV-F 15-17	20	15	50	29	237	233	225	217	208	190	182	165	147	DN 50	DN 50

Tipo Type	Potencia		"A"		Caudal m ³ /h / Flow m ³ /h							Diámetro		
	HP	KW	III 400	III 690	0	4	8	12	16	20	24	28	ASP.	IMP.
					Altura m.c.a. / Height w.c.m.									
XV-F 20-5	7,5	5,5	11,3	6,6	70	70	69	67	63	58	50	37	DN 50	DN 50
XV-F 20-7	10	7,5	14,7	8,5	102	100	97	95	90	82	69	54	DN 50	DN 50
XV-F 20-10	15	11	21	12,2	145	144	142	139	130	118	103	80	DN 50	DN 50
XV-F 20-14	20	15	29	16,8	204	203	200	195	185	168	145	113	DN 50	DN 50
XV-F 20-17	25	18,5	35	20,2	250	247	245	238	226	207	179	140	DN 50	DN 50

Tipo Type	Potencia		"A"		Caudal m ³ /h / Flow m ³ /h								Diámetro	
	HP	KW	II 400	III 690	0	6	12	18	24	30	36	40	ASP.	IMP.
					Altura m.c.a. / Height w.c.m.									
XV-F 32-3	7,5	5,5	11,3	6,6	58	58	57	54	48	42	35	29	DN 65	DN 65
XV-F 32-4	10	7,5	14,7	8,5	76	76	75	72	65	58	48	39	DN 65	DN 65
XV-F 32-6	15	11	21	12,2	116	116	114	109	101	90	74	61	DN 65	DN 65
XV-F 32-8	20	15	29	16,8	154	156	152	146	136	120	100	82	DN 65	DN 65
XV-F 32-10	25	18,5	35	20,2	194	197	192	183	170	152	126	106	DN 65	DN 65
XV-F 32-12	30	22	42	24,3	232	237	232	222	205	185	152	127	DN 65	DN 65
XV-F 32-14	40	30	64	37	273	278	275	270	244	217	180	153	DN 65	DN 65

Tipo Type	Potencia		"A"		Caudal m ³ /h / Flow m ³ /h								Diámetro	
	HP	KW	II 400	III 690	0	10	18	26	34	42	50	58	ASP.	IMP.
					Altura m.c.a. / Height w.c.m.									
XV-F 45-2	10	7,5	14,7	8,5	50	50	49	47	45	40	34	29	DN 80	DN 80
XV-F 45-3	15	11	21	12,2	75	74	73	72	69	63	53	44	DN 80	DN 80
XV-F 45-4	20	15	29	16,8	100	101	100	97	92	84	71	57	DN 80	DN 80
XV-F 45-5	25	18,5	35	20,2	125	127	124	122	117	105	90	75	DN 80	DN 80
XV-F 45-6	30	22	42	24,3	151	152	151	149	139	128	118	90	DN 80	DN 80
XV-F 45-9-2	40	30	64	37	218	222	221	216	202	186	158	128	DN 80	DN 80
XV-F 45-10	50	37	69	40	252	255	253	249	232	218	185	153	DN 80	DN 80
XV-F 45-13-2	60	45	83	48	320	330	328	322	300	280	237	196	DN 80	DN 80

Tipo Type	Potencia		"A"		Caudal m ³ /h / Flow m ³ /h								Diámetro	
	HP	KW	II 400	III 690	0	12	24	36	48	60	72	85	ASP.	IMP.
					Altura m.c.a. / Height w.c.m.									
XV-F 64-2	15	11	21	12,2	60	58	56	53	49	45	40	33	DN 100	DN 100
XV-F 64-3-1	20	15	29	16,8	78	77	76	74	68	62	54	42	DN 100	DN 100
XV-F 64-4-2	25	18,5	35	20,2	98	98	97	94	86	78	68	52	DN 100	DN 100
XV-F 64-4	30	22	42	24,3	118	117	113	109	102	94	84	68	DN 100	DN 100
XV-F 64-6-2	40	30	64	37	156	155	154	149	140	128	114	89	DN 100	DN 100
XV-F 64-7-1	50	37	69	40	195	194	191	185	173	160	143	115	DN 100	DN 100
XV-F 64-8-1	60	45	83	48	223	226	223	217	204	187	167	135	DN 100	DN 100

Tipo Type	Potencia		"A"		Caudal m ³ /h / Flow m ³ /h								Diámetro	
	HP	KW	II 400	III 690	0	18	36	54	72	90	108	120	ASP.	IMP.
					Altura m.c.a. / Height w.c.m.									
XV-F 90-2-2	15	11	21	12,2	48	46	44	42	37	28	16	8	DN 100	DN 100
XV-F 90-2	20	15	29	16,8	68	64	59	54	48	42	32	24	DN 100	DN 100
XV-F 90-3-2	25	18,5	35	20,2	80	78	76	68	61	50	34	24	DN 100	DN 100
XV-F 90-3	30	22	42	24,3	102	96	89	82	74	64	50	40	DN 100	DN 100
XV-F 90-4	40	30	64	37	136	130	123	110	99	88	70	56	DN 100	DN 100
XV-F 90-5	50	37	69	40	170	162	152	140	127	110	88	72	DN 100	DN 100
XV-F 90-6	60	45	83	48	204	195	184	168	154	135	108	89	DN 100	DN 100



■ Aplicaciones:

Las electrobombas de la serie VX-SS son centrífugas verticales multicelulares con bocas de aspiración e impulsión en línea, que por su elevado rendimiento y los materiales que las componen las hace ideales para su uso en instalaciones industriales especiales para su uso en aguas abrasivas como pueden ser sistemas de osmosis inversa, agua salada y agua con ácidos en disolución.

■ Características constructivas:

Turbinas, difusores, eje, camisa externa y cámaras intermedias, base aspiración-impulsión, íntegramente en acero inoxidable AISI 316. Cuerpo superior en fundición de alta resistencia no en contacto con el líquido.

Las versiones VX SS- F equipan bridas DIN **y no incorporan contrabridas de serie:**

VX SS-F 4	DN 32
VX SS-F 8	DN 40
VX SS-F 16	DN 50 paso interior de 65 mm.

■ Motor:

Motor asíncrono, tipo cerrado y de ventilación externa, apto para trabajo continuo. Grado de protección IP-54, aislamiento clase F, a 2.850 r.p.m. Los modelos monofásicos a 230 V incorporan un protector térmico y condensador permanente.

Temperatura del líquido a bombear	-15° C a +120° C
Temperatura máxima ambiente	40° C
Presión máxima de ejercicio:25 bar

■ Applications:

The electropumps of the VX-SS series are multicellular vertical centrifugal units with suction and drive in line, and their high output materials makes them ideal for use in pressure equipment, industrial installations that works with aggressive water like reverse osmosis, salt water and water with acids.

■ Construction:

Impellers, diffusers, shaft, external cladding and intermediate chambers, suction-drive base entirely in AISI 316 stainless steel. Upper body in high strength cast iron not in contact with the pumped liquid.

The VX SS - F versions are fitted with DIN flanges **and do not include counter-flanges as standard.**

VX SS-F 4	DN 32
VX SS-F 8	DN 40
VX SS-F 16	DN 50 interior pitch 65 mm

■ Motor:

Sealed asynchronous with external ventilation, suitable for continuous work. IP-55 protection, class F insulation, at 2,850 rpm. Single phase versions at 230 V include a thermal protector and permanent capacitor.

Maximum water temperature	-15° C to +120° C
Maximum ambient temperature	40° C
Maximum working pressure:25 bar

Tipo Type	Con. µF	Potencia		"A"			Caudal m³/h / Flow m³/h								Diámetro	
		HP	KW	II 230	III 230	III 400	0	0,8	2,4	3,6	4,8	6	6,6	7,2	ASP.	IMP.
							Altura m.c.a. / Height w.c.m.									
VX SS-F 4-40 M/T	25	1	0,75	5,2	3,3	1,9	39	38	36	33	29	25	22	18	1 1/4"	1 1/4"
VX SS-F 4-50 M/T	45	1,5	1,1	12	4,3	2,5	49	47	44	42	37	31	30	23	1 1/4"	1 1/4"
VX SS-F 4-60 M/T	45	1,5	1,1	12	4,3	2,5	59	56	53	50	44	38	32	27	1 1/4"	1 1/4"
VX SS-F 4-70 M/T	45	2	1,5	12	5,9	3,4	69	64	61	58	51	44	38	32	1 1/4"	1 1/4"
VX SS-F 4-80 M/T	45	2	1,5	12	5,9	3,4	79	76	71	67	59	50	45	37	1 1/4"	1 1/4"
VX SS-F 4-100T	-	3	2,2	-	8,3	4,8	98	95	90	82	72	61	52	46	1 1/4"	1 1/4"
VX SS-F 4-120T	-	3	2,2	-	8,3	4,8	118	114	107	99	87	73	64	54	1 1/4"	1 1/4"
VX SS-F 4-140T	-	4	3	-	10,9	6,3	136	125	124	116	102	85	74	63	1 1/4"	1 1/4"
VX SS-F 4-160T	-	4	3	-	10,9	6,3	156	150	142	132	116	97	83	72	1 1/4"	1 1/4"
VX SS-F 4-190T	-	5,5	4	-	13,8	8	185	179	170	157	138	114	100	86	DN 32	DN 32
VX SS-F 4-220T	-	5,5	4	-	13,8	8	215	204	196	181	160	131	120	101	DN 32	DN 32
VX SS-F 4-240T *	-	7,5	5,5	-	21,5	12,4	220	216	213	198	175	143	135	110	DN 32	DN 32
VX SS-F 4-260T *	-	7,5	5,5	-	21,5	12,4	242	237	230	213	189	156	144	120	DN 32	DN 32

B

Tipo Type	Potencia		"A"		Caudal m³/h / Flow m³/h								Diámetro	
	HP	KW	III 230	III 400	0	3	6	8	9	10	11	12	ASP.	IMP.
					Altura m.c.a. / Height w.c.m.									
VX SS-F 8-40T	2	1,5	5,9	3,4	45	42	40	38	35	32	28	26	1 1/2"	1 1/2"
VX SS-F 8-50T	3	2,2	8,8	5,1	55	53	50	46	44	40	34	32	1 1/2"	1 1/2"
VX SS-F 8-60T	3	2,2	8,8	5,1	66	64	60	57	52	49	42	39	1 1/2"	1 1/2"
VX SS-F 8-80T	4	3	11,8	6,8	88	85	80	76	70	62	58	52	1 1/2"	1 1/2"
VX SS-F 8-100T	5,5	4	16,8	9,7	110	106	100	95	88	80	74	65	1 1/2"	1 1/2"
VX SS-F 8-120T	5,5	4	16,8	9,7	130	127	119	114	104	98	84	77	1 1/2"	1 1/2"
VX SS-F 8-140T *	7,5	5,5	21,5	12,4	154	149	130	125	122	115	98	92	DN 40	DN 40
VX SS-F 8-160T *	7,5	5,5	21,5	12,4	178	171	160	150	138	130	118	104	DN 40	DN 40
VX SS-F 8-180T *	10	7,5	28	16,4	198	193	181	174	160	148	130	120	DN 40	DN 40
VX SS-F 8-200T *	10	7,5	28	16,4	220	214	200	188	175	162	140	132	DN 40	DN 40

Tipo Type	Potencia		"A"		Caudal m³/h / Flow m³/h								Diámetro	
	HP	KW	III 230	III 400	0	6	12	15	17	18	19	21	ASP.	IMP.
					Altura m.c.a. / Height w.c.m.									
VX SS-F 16-30T	4	3	11,8	6,8	45	43	40	37	35	32	30	27	DN 50	DN 50
VX SS-F 16-40T	5,5	4	16,8	9,7	60	58	54	52	48	44	40	37	DN 50	DN 50
VX SS-F 16-50T *	7,5	5,5	21,5	12,4	75	72	68	65	61	56	50	46	DN 50	DN 50
VX SS-F 16-60T *	7,5	5,5	21,5	12,4	88	87	81	78	72	68	64	58	DN 50	DN 50
VX SS-F 16-70T *	10	7,5	28	16,4	103	101	95	90	85	80	71	67	DN 50	DN 50
VX SS-F 16-80T *	10	7,5	28	16,4	118	116	108	102	98	92	84	76	DN 50	DN 50
VX SS-F 16-100T *	15	11	40	23,5	149	145	136	130	125	118	110	98	DN 50	DN 50
VX SS-F 16-120T	15	11	40	23,5	179	174	163	156	150	140	126	118	DN 50	DN 50
VX SS-F 16-140T *	20	15	50	29	208	204	190	184	168	163	154	140	DN 50	DN 50
VX SS-F 16-160T *	20	15	50	29	239	232	220	208	204	188	165	159	DN 50	DN 50

* Voltaje de Serie 400/690 V (bajo demanda 230/400 V) / * Standard voltage 400/690 V (under demand 230/400 V)



VAT-127 L



VAT-163 L



VAT-205

■ Aplicaciones:

Bombas centrífugas multicelulares verticales, muy adecuadas para formar equipos con variador de frecuencia. Bombas silenciosas y de un gran rendimiento hidráulico.

BAJO DEMANDA SE PUEDEN FABRICAR CON ENTRADA Y SALIDA EN EL MISMO LADO.

■ Características constructivas:

Series VAT 127 L y 163 L: cuerpo aspiración e impulsión en fundición GG-25. Camisa hidráulica, eje y tornillería en acero inoxidable, turbinas difusores y tapas difusor en Noryl inyectado de alta calidad con insertos en bronce para garantizar una elevada resistencia al desgaste. Cierre mecánico en cerámica carbón y de fácil acceso.

Series VAT 205: cuerpo aspiración e impulsión, soporte motor, acomplamiento y difusores en fundición gris, eje en acero inoxidable. Turbinas en noryl. Cierre mecánico de cerámica carbón y de fácil acceso.

■ Motor:

Motor asíncrono standard, cerrado de ventilación externa, apto para trabajo continuo.

Grado de protección IP-55. Aislamiento clase F (calentamiento "B") tropicalizados a 2.850 r.p.m. 50 Hz y bajo demanda 60 Hz y otras tensiones.

Temperatura máxima del agua:
Temperatura máxima ambiente:

50° C
50° C

■ Applications:

Vertical multicellular centrifugal pumps. Like all the verticals, they are very suitable for use in pressure installations, or as a Jockey pump in fire-fighting units.

■ Construction:

VAT 127 L and VAT 163 L SERIES: Suction and drive chambers, motor support and coupling in cast iron impellers and diffusers in GFN-2 injected Noryl, capped diffusers in brass, ambient diffuser cladding and shaft in stainless steel, easy access mechanical seal.

VAT 205 SERIES: Suction and drive chambers, motor support and coupling in cast iron. Impellers in bronze capped Noryl. Easy access mechanical seal.

■ Motor:

Sealed asynchronous with external ventilation, IEC Standard, IP-55 protection.

Maximum water temperature:

50° C

Maximum ambient temperature:

50° C

Centrífugas Verticales Multicelulares

Serie "VAT"

Tipo "L" Type "L"	Potencia		"A"		Caudal m ³ /h / Flow m ³ /h													Diámetro	
	HP	KW	III 230	III 400	0	3	4	5	6	7	8	9	10	11	12	14	ASP.	IMP.	
					Altura m.c.a. / Height w.c.m.														
VAT 127 L-4	2	1,5	5,2	3	41	40,5	40	38	36	34	30	27	23	18	14	7	1 1/2"	1 1/2"	
VAT 127 L-5			5,8	3,4	51	50	49	47	45	42	38	34	29	23	17	9	1 1/2"	1 1/2"	
VAT 127 L-6	3	2,2	8,1	4,7	61	59,5	58	56	54	50	46	40	35	28	21	13	1 1/2"	1 1/2"	
VAT 127 L-7					71	70	68	66	63	59	54	47	40	33	25	14			
VAT 127 L-8					81	80	78	76	72	68	62	55	47	38	30	17			
VAT 127 L-9	4	3	10,8	6,2	91	89	88	85	82	76	70	61	52	43	33	19	1 1/2"	1 1/2"	
VAT 127 L-10					101	99	97	95	91	85	78	69	59	49	38	22			
VAT 127 L-11	5,5	4	13,5	7,8	111	109	107	105	101	94	86	77	66	55	43	25	1 1/2"	1 1/2"	
VAT 127 L-12					121	119	117	115	110	103	94	85	73	61	48	28			
VAT 127 L-13					131	129	127	125	120	112	102	93	80	67	53	30			

B

Tipo "L" Type "L"	Potencia		"A"		Caudal m ³ /h / Flow m ³ /h													Diámetro	
	HP	KW	III 230	III 400	0	6	8	10	12	14	16	18	20	22	24	26	ASP.	IMP.	
					Altura m.c.a. / Height w.c.m.														
VAT 163 L-2	4	3	10,8	6,3	35	32	32	31,5	30	28	27	25	23	19	15	12	2"	2"	
VAT 163 L-3					52	47	46,5	45	44	40	38	34	30	25	21	17			
VAT 163 L-4	5,5	4	13,5	7,8	68	63	61	59	57	54	50	45	40	34	29	21	2"	2"	
VAT 163 L-5*	7,5	5,5	-	11,8	85	77,5	76	74	72	70	66	60	54	45	38	28	2"	2"	
VAT 163 L-6*					102	93	91	90	86	81	76	70	64	54	46	35			
VAT 163 L-7*	10	7,5	-	15,4	119	110	108	105	102	97	91	84	74	63	52	40	2"	2"	
VAT 163 L-8*					136	123	119	116	112	107	103	96	85	76	64	51			
VAT 163 L-9*	12,5	9,3	-	18,5	154	141	138	134	127	123	118	110	95	88	76	63	2"	2"	

* Voltaje de Serie 400/690 V (bajo demanda 230/400 V) / *Standard voltage 400/690 V (under demand 230/400 V)

Tipo Type	Potencia		"A"		Caudal m ³ /h / Flow m ³ /h													Diámetro	
	HP	KW	III 400	III 690	0	5	10	15	20	25	30	35	38	40	42	45	ASP.	IMP.	
					Altura m.c.a. / Height w.c.m.														
VAT 205 - 2*	10	7,5	15,4	-	53	52	51	49,5	48	44,5	42	39,5	36	33	28	23	2 1/2"	2 1/2"	
VAT 205 - 3*	12,5	9,3	18,5	-	79	78	77	75	73	69	64	59	54	48	42	35	2 1/2"	2 1/2"	
VAT 205 - 4*	20	15	29,4	-	105	104	103	100	97	92	85	79	71	69	56	47	2 1/2"	2 1/2"	
VAT 205 - 5*	20	15	29,4	-	132	130	128	124,5	122	115	106	98	89	79	70	58	2 1/2"	2 1/2"	
VAT 205 - 6*	25	18,5	34	-	158	156	154	149	146	138	127	116	106	95	84	70	2 1/2"	2 1/2"	

* Voltaje de Serie 400/690 V (bajo demanda 230/400 V) / *Standard voltage 400/690 V (under demand 230/400 V)

■ Aplicaciones:

La bomba multicelular vertical, por su elevado rendimiento y funcionamiento silencioso es particularmente indicada para la formación de equipos de presión y como bomba jockey en equipos contraincendios.

■ Características constructivas:

Construidas con acoplamiento rígido que permite el cambio de cierre mecánico sin desmontar toda la bomba. Cuerpo de aspiración, impulsión y cuerpos intermedios en fundición gris. Turbinas y difusores en latón. A partir de 8 turbinas equipan cojinete intermedio. Eje en acero inoxidable.

■ Motor:

Motor asíncrono standard, cerrado de ventilación externa, apto para trabajo continuo.

Grado de protección IP-55. Aislamiento clase F (calentamiento "B") tropicalizados a 2.850 r.p.m. 50 Hz y bajo demanda 60 Hz y otras tensiones.

Temperatura máxima del agua: 95°C

Temperatura máxima ambiente: 50°C



■ Applications:

Multicellular pumps are characterised as having a greater hydraulic output than those with a single stage, and the vertical pumps work more silently and need less space for location, which makes them ideal for application in pressure units, as a jockey pumps in fire fighting sets.

■ Construction:

Built with a rigid coupling allowing the mechanical seal to be changed without dismantling the whole of the pump. Drive and intermediate bodies in cast iron. Brass impellers and diffusers. Stainless steel shaft.

■ Motor:

Sealed, asynchronous, with external ventilation, IP-55 protection, class B insulation, 2,850 rpm.

*** To order it may be supplied with the Suction and Drive on the same side.**

Maximum water temperature: 95°C

Maximum ambient temperature: 50°C

Tipo Type	Potencia		"A"		Caudal m ³ /h / Flow m ³ /h															Diámetro	
	HP	KW	III	III	0	2	4	6	7	8	9	10	11	12	13	14	15	ASP.	IMP.		
			230	400	Altura m.c.a. / Height w.c.m.																
V 31	2	1,5	4,5	2,6	47	45	40	34	30	26								11/2"	11/2"		
V 41	2	1,5	6	3,5	62	60	52	43	37	32								11/2"	11/2"		
V 51	2	1,5	6	3,5	77	75	68	57	50	45								11/2"	11/2"		
V 61	3	2,2	9	5,2	93	90	83	72	65	55								11/2"	11/2"		
V 71	3	2,2	9	5,2	106	103	95	80	70	60								11/2"	11/2"		
V 32	2	1,5	6	3,5	47	45	43	40	38	35	32	26						11/2"	11/2"		
V 42	2	1,5	6	3,5	63	60	56	51	48	45	40	35						11/2"	11/2"		
V 52	3	2,2	9	5,2	87	83	77	68	64	59	54	48						11/2"	11/2"		
V 62	4	3	12	6,9	104	100	94	85	80	73	67	60						11/2"	11/2"		
V 72	4	3	12	6,9	117	113	108	100	95	88	82	75						11/2"	11/2"		
V 82	4	3	12	6,9	133	130	123	115	111	105	98	90						11/2"	11/2"		
V 92	5,5	4	16,5	9,5	148	145	138	130	124	118	112	104						11/2"	11/2"		
V 102*	7,5	5,5	21,6	12,5	166	160	150	140	133	125	119	110						11/2"	11/2"		
V 112*	7,5	5,5	21,6	12,5	184	176	164	150	144	135	127	117						11/2"	11/2"		
V 33	2	1,5	6	3,5	50	48	46	43	41	39	37	35	33	30	27	24	20	2"	2"		
V 43	3	2,2	9	5,2	67	64	60	56	54	51	48	45	42	39	35	31	25	2"	2"		
V 53	4	3	12	6,9	84	79	74	68	65	62	58	54	50	45	41	36	30	2"	2"		
V 63	5,5	4	16,5	9,5	100	96	90	84	80	77	73	69	64	59	53	44	34	2"	2"		
V 73	5,5	4	16,5	9,5	115	110	104	96	93	90	85	81	76	70	63	52	38	2"	2"		
V 83*	7,5	5,5	21,6	12,5	133	125	117	109	104	100	95	90	85	79	72	64	50	2"	2"		
V 93*	7,5	5,5	21,6	12,5	150	142	134	125	120	115	110	105	100	93	85	75	60	2"	2"		

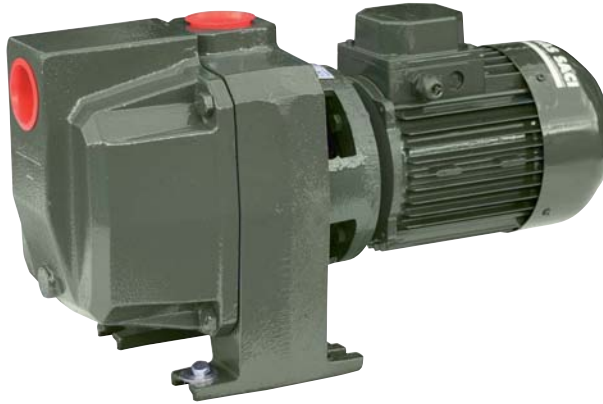

C

■ Aplicaciones:

Bomba de cebado automático, estando lleno el cuerpo de la bomba. Exenta de válvulas o mecanismos que puedan dificultar el paso interior.

Bomba ideal para achiques o multiusos por su gran facilidad de cebado.

Admite al trasvase de líquidos ligeramente turbios o arenosos.

■ Características constructivas:

Cuerpo de bomba y difusor en fundición de alta resistencia, turbina abierta en latón, eje en acero inoxidable y cierre mecánico en cerámica-carbón.

■ Motor:

Motor eléctrico de tipo cerrado con ventilación externa, y grado de protección IP-54, 2.850 r.p.m..

■ Applications:

A self-priming pump, when the pump body is full. No valves or interior mechanisms to obstruct the interior passage of the liquid. It admits the transfer of liquids that are lightly turbid or sandy.

■ Construction:

Pump body and pump support in cast iron. Open impeller in brass and shaft in stainless steel. Mechanical seal in carbon ceramic.

■ Motor:

Sealed asynchronous with external ventilation. IP-54 protection at 2,850 rpm, 50 Hz.

Maximum water temperature:

95° C

Temperatura máxima del agua:

95° C

Tipo Type	Potencia		"A"			Cond. µF	Caudal m³/h / Flow m³/h										Diámetro	
	HP	KW	II 230	III 230	III 400		1,5	3	4	8	10	12	17	22	25	34	ASP	IMP
																	Altura m.c.a. / Height w.c.m.	
AC1-M	0,5	0,37	3	-	-	14	16	14	13	6							1 1/2"	1 1/2"
AC1-T			-	1,9	1,1	-												
AC2-M	0,75	0,55	3,5	-	-	20	18	17	16	13	11	11					1 1/2"	1 1/2"
AC2-T			-	2,77	1,6	-												
AC3-M	1	0,75	4,8	-	-	25	19,5	19	18	16	15	13	6				1 1/2"	1 1/2"
AC3-T			-	3	1,8	-												
AC4-M	1,5	1,1	6	-	-	35	20,5	20	19	17	16	14	10	5			2"	2"
AC4-T			-	4,5	2,6	-												
AC5-T	2	1,5	-	6	3,5	-	21	20,5	20	18	17	16	12	8	6		2"	2"
AC6-T	3	2,2	-	9	5,2	-			20	19	18,5	18	16	13	11	5	2"	2"

Serie "MP"	46
Serie "MULTINOX-N"	47
Serie "JET"	48
Serie "AP"	49
Serie "PE"	50
Bombas para Fuentes Decorativas y Acuarios	51
Serie "NOVA - FEKA"	52
Serie "DRENOX"	53



Eq. MP/Prescontrol

■ Aplicaciones:

Electrobomba centrífuga multicelular horizontal ideal para formar equipo de presión de pequeño y mediano caudal, pequeños riegos por aspersión, etc.

Las principales ventajas obtenidas con este modelo son las siguientes:

- Alto rendimiento hidráulico. Mínimo consumo de energía eléctrica.

- **EXTREMADAMENTE SILENCIOSA.**

■ Características constructivas:

Cuerpo aspiración e impulsión en fundición de hierro .

Eje bomba en AISI-304. Turbina en NORYL reforzada con fibra de vidrio encasquillada en bronce y chaveta en bronce, incluyen aros de rozamiento en acero inoxidable. Difusor en NORYL reforzado con fibra de vidrio. Cierre mecánico en Cerámica-Grafito.

■ Motor:

Asíncrono cerrado de ventilación externa, grado de protección IP-44, con motoprotector incorporado de rearme automático en las versiones monofásicas. Grado de aislamiento clase F.

MAXIMA TEMPERATURA AGUA: +50° C
MAXIMA TEMPERATURA AMBIENTE: +45° C

■ Applications:

A horizontal multicellular centrifugal electropump ideal to use as a pressure unit with a small or medium flow, small irrigation by aspersion, etc.

The main advantages of this model are the following:

- High hydraulic output. Minimum electrical power consumption.

- **EXTREMELY SILENT.**

■ Construction:

Inlet and outlet body in cast iron. Impeller in NORYL reinforced with bronze-capped glass fibre and bronze pins, with contact rings in stainless steel. Diffuser in NORYL reinforced with glass fibre. Shaft in AISI 304 stainless steel. Mechanical seal in graphite ceramic.

■ Motor:

Sealed asynchronous with external ventilation. IP-44 protection, with automatic reset built-in motor protection in the single phase versions. Class F insulation.

MAXIMUM WATER TEMPERATURE: +50° C
MAXIMUM AMBIENT TEMPERATURE: +45° C

Tipo Type	Con. µF	Potencia		"A"			Caudal m ³ /h / Flow m ³ /h									Diámetro	
							HP	KW	II 230	III 230	III 400	0	0,6	1,2	2,4		
		Altura m.c.a. / Height w.c.m.															ASP.
MP 836 M	12,5	0,8	0,6	2,9	-	-	36	33	30	26	20	14	9	3		1"	1"
MP 836 T	-			-	2	1,2											
MP 848 M	12,5	1,1	0,8	4	-	-	48	44	40	34	28	22	16	5		1"	1"
MP 848 T	-			-	2,6	1,5											
MP 860 M	16	1,3	1	5,5	-	-	60	57	52	44	38	32	24	6	1	1"	1"
MP 860 T	-			-	2,9	1,7											

Centrífugas Horizontales Multicelulares

Serie "MULTINOX-N"



■ Aplicaciones:

Electrobomba centrífuga multicelular horizontal ideal para formar equipo de presión de pequeño y mediano caudal, pequeños riegos por aspersión, etc.

Las principales ventajas obtenidas con este modelo son las siguientes:

- Alto rendimiento hidráulico. Mínimo consumo de energía eléctrica.

- **EXTREMADAMENTE SILENCIOSA.**

- **MÁS HIGIÉNICA**, no incorporan ningún componente en fundición, lo cual evita oxidaciones y por tanto no hay desprendimientos ferríticos ni coloración en el agua.

Máxima temperatura del agua: +50° C

■ Características constructivas:

Cuerpo de bomba en acero inoxidable AISI 304.

Eje bomba en AISI-304. Turbina en NORYL reforzada con fibra de vidrio encasquillada en bronce y chaveta en bronce, incluyen aros de rozamiento en acero inoxidable. Difusor en NORYL reforzado con fibra de vidrio. Cierre mecánico en Cerámica-Grafito.

■ Motor:

Asíncrono cerrado de ventilación externa, grado de protección IP-44, con motoprotector incorporado de rearme automático en las versiones monofásicas. Grado de aislamiento clase F.

■ Applications:

A horizontal multicellular centrifugal electropump ideal to use as a pressure unit with a small or medium flow, small irrigation by aspersion, etc.

The main advantages of this model are the following:

- High hydraulic output. Minimum electrical power consumption.

- **EXTREMELY SILENT.**

- **MORE HYGIENIC**, not including any cast iron component, avoiding rusting and therefore preventing iron release or colouring in the water.

Maximum water temperature: +50° C.

■ Construction:

Pump body in AISI 304 stainless steel. Impeller in NORYL reinforced with bronze-capped glass fibre and bronze pins, with contact rings in stainless steel. Diffuser in NORYL reinforced with glass fibre. Shaft in AISI 304 stainless steel. Mechanical seal in graphite ceramic.

■ Motor:

Sealed asynchronous with external ventilation. IP-44 protection, with automatic reset built-in motor protection in the single phase versions. Class F insulation.

Tipo Type	Con. µF	Potencia		"A"			Caudal m ³ /h / Flow m ³ /h								Diámetro		
		HP	KW	II 230	III 230	III 400	0	1,2	2,4	3,6	4,8	6	7,2	9,6	12	ASP.	IMP.
							Altura m.c.a. / Height w.c.m.										
MULTINOX N 80-36 M	12,5	0,8	0,6	2,9	-	-	36	30	26	14	3					1"	1"
MULTINOX N 80-36 T	-			-	2	1,2											
MULTINOX N 80-48 M	12,5	1,1	0,8	4	-	-	48	40	34	22	5					1"	1"
MULTINOX N 80-48 T	-			-	2,6	1,5											
MULTINOX N 80-60 M	16	1,3	1	4,8	-	-	60	52	44	32	6					1"	1"
MULTINOX N 80-60 T	-			-	2,9	1,7											
MULTINOX N 120-48 M	16	1,5	1,1	4,9	-	-	48	46	41	35	27	18	3			1"	1"
MULTINOX N 120-48 T	-			-	3,6	2,1											
MULTINOX N 120-60 M	20	1,7	1,25	5,8	-	-	60	58	50	40	30	17	5			1"	1"
MULTINOX N 120-60 T	-			-	3,9	2,5											
MULTINOX N 200-40 M	20	1,5	1,1	7	-	-	40	38	37	36	32	29	24	14	5	1 1/4"	1 1/4"
MULTINOX N 200-40 T	-			-	3,6	2,1											
MULTINOX N 200-52 M	25	1,8	1,3	8,5	-	-	52	51	49	45	42	37	32	20	7	1 1/4"	1 1/4"
MULTINOX N 200-52 T	-			-	5	2,9											
MULTINOX N 200-65 M		2	1,5	9,3	-	-	65	63	60	55	50	45	38	26	9	1 1/4"	1 1/4"
MULTINOX N 200-65 T	-			-	6	3,5											

D



ASPIRACION MAXIMA 9 METROS.

MAXIMUM SUCTION HEIGHT 9 METERS.

■ Aplicaciones:

Bomba autoaspirante con óptima capacidad de aspiración incluso en presencia de gas en el agua. Particularmente indicada para el empleo en grupos de presión domésticos con aspiración negativa, pequeños riegos y jardines, etc. Para aspiraciones superiores a 4 mts. instalar tuberías de aspiración de mayor diámetro al indicado.

■ Características constructivas:

Cuerpo bomba y soporte motor en fundición con tratamiento anticorrosivo incluso en la superficie interna. Turbinas, difusor y tubo Venturi en tecnopolímero-A, eje en acero inoxidable y cierre mecánico en cerámica carbón.

■ Motor:

Asíncrono y de ventilación externa. Protección termo-amperimétrica incorporada y condensador fijo en las versiones monofásicas. Protección IP-44 aislamiento tipo F.

■ Applications:

A self-priming pump with optimal suction capacity even when there is gas in the water. Especially recommended for use in domestic pressure units with negative suction, small irrigation installations and gardens, etc. For suctions of over 4 metres, install suction piping of a larger diameter than that indicated.

■ Construction:

Pump body and motor support in cast iron with rust-proofing even on the interior surface. Impellers, diffuser and Venturi in techno polymer-A, shaft in stainless steel and mechanical seal in carbon ceramic.

■ Motor:

Asynchronous with external ventilation. Built-in thermo-amperimetric protection and fixed capacitor in the single phase versions. IP-44 protection, type F insulation.

Tipo Type	Con. µF	Potencia		"A"			Caudal m ³ /h / Flow m ³ /h										Diámetro	
		HP	KW	II 230	III 230	III 400	0	1,2	1,8	2,4	3	3,6	6	9	10,5	ASP.	IMP.	
							Altura m.c.a. / Height w.c.m.											
JET 82 M	12,5	0,8	0,59	3,8	-	-	47	34	30	26	23,5	21				1"	1"	
JET 82 T	-			-	2,8	1,6												
JET 102 M	16	1	0,75	5,1	-	-	54	41	37	33	29	26				1"	1"	
JET 102 T	-			-	3,3	1,9												
JET 15 M	25	1,5	1,1	7,2	-	-	61	57	52	50	46	43				1 1/4"	1"	
JET 15 T	-			-	5,2	3												
JET 20 M	40	2	1,5	9	-	-	41	39	38	37	36	33	30	24	21	1 1/2"	1 1/4"	
JET 25 M	40			10	-	-												
JET 25 T	-	2,5	1,85	-	6,9	4	62	59	57	54	51	42	39			1 1/4"	1"	

Centrífugas de Aspiración Profunda

Serie "AP"

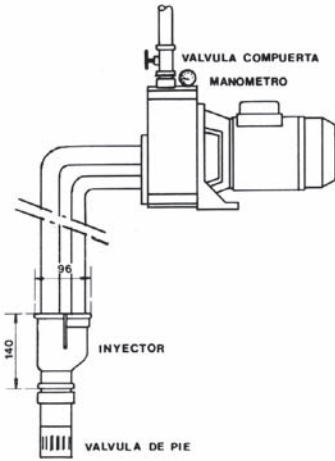

D

■ Aplicaciones:

Bomba centrífuga autoaspirante para aspiración profunda hasta 50 metros, por mediación de un inyector. Idónea para pozos de 4" o mayores.

■ Características constructivas:

Cuerpo y soporte en fundición gris, con tratamiento anticorrosivo incluso en su superficie interna, turbinas y difusor interno Venturi en tecnopolímero-A, eje en acero inoxidable y cierre mecánico en cerámica-carbón. El modelo AP 10.2 es monoturbina y los modelos AP 15 y AP 25 biturbina. Temperatura del líquido a bombear de 0° C a +40° C. Máxima temperatura ambiente +40° C. Máxima presión de trabajo 8 Kg./cm².

■ Motor:

Asíncrono, cerrado y de ventilación externa. Protección termo-amperimétrica incorporada y condensador fijo en la versión monofásica. Grado de protección IP-44, según normativa CEI a 2.850 r.p.m., 50 Hz.

■ Applications:

A self-priming pump for deep suction up to 50 metres by means of an injector. Ideal for 4" wells or larger.

■ Construction:

Pump body and motor support in grey cast iron with rust-proofing even on the interior surface, impellers diffuser, and Venturi in technopolymer-A. Shaft in stainless steel and mechanical seal in carbon ceramic. The AP 10.2 is single impeller and the AP 15 and AP 25 are double impeller.

Temperature of the liquid to be pumped from 0° C to +40° C. Maximum ambient temperature +40° C. Maximum working pressure 8 Kg/cm².

■ Motor:

Sealed asynchronous with external ventilation. Built-in thermo-amperimetric protection and fixed capacitor in the single phase versions. IP-44 protection according to CEI standard at 2,850 rpm, 50 Hz.

Tipo Type	Cond. µF	Potencia		"A"			Altura de ASP.	Altura m.c.a. / Height w.c.m.					Diámetro		
								15	20	30	40	50	ASP.	IMP.	
															Caudal m ³ /h / Flow m ³ /h
HP	KW	II 230	III 230	III 400											
AP 10.2 M	16	1	0,75	4,8	-	-	*20		1,5	0,8	0,2				
							30		1,1	1	0,7				
AP 10.2 T	-			-	3,3	1,9	40		0,9	0,8	0,2			1 1/4"-1"	1"
							*30		2	1,8	1,6	1,1			
AP 15 M	25	1,5	1,1	7,8	-	-	35		1,3	1,2	1,1	0,9		1 1/4"-1"	1"
							40		1,1	1	0,9	0,5			
AP 15 T	-			-	5,4	3,1	50		0,9	0,8	0,7	0,4			
							*30		2,5	2,3	1,8	1,2			
AP 25 M	40	2,5	1,83	10,8	-	-	35		1,55	1,45	1,3	1,11		1 1/4"-1"	1"
							40		1,3	1,2	1,1	0,7			
AP 25 T	-			-	6,9	4	50		1,1	1	0,9	0,55			

Para obtener estos caudales es necesario utilizar la tobera de mayor diámetro interior, que se suministra bajo demanda.
To obtain this performances it is necessary to use a bigger diameter venturi, that can be supplied under demand.



■ **Aplicaciones:**

Las electrobombas periféricas monobloc serie PE, son particularmente indicadas para servicios en los que sea necesario una presión elevada y un caudal limitado. Son también indicadas para pequeños equipos de presión. El agua debe estar libre de arena.

■ **Características constructivas:**

Cuerpo y soporte bomba-motor en fundición. Turbina en bronce. Eje de acero inoxidable, sello mecánico en carbono de silicio.

TEMPERATURA MAXIMA DEL AGUA: 70° C.

■ **Motor:**

Motor eléctrico cerrado de ventilación externa. La versión monofásica incorpora protector térmico y condensador permanente. Grado de protección IP-44. Aislamiento Tipo B.

■ **Applications:**

The PE series peripheral single block electropumps are particularly recommended for services requiring a high pressure and limited flow. They are also recommended for small pressure units. The water must be sand-free.

■ **Construction:**

Pump body and motor support in cast iron. Impeller in bronze. Stainless steel shaft and mechanical seal in silicon carbide.

MAXIMUM WATER TEMPERATURE: 70° C.

■ **Motor:**

Sealed electric with external ventilation. The single phase version includes a thermal protector and permanent capacitor. IP-44 protection. Type B insulation.

Tipo Type	Con. µF	Potencia		"A"			Caudal m ³ /h / Flow m ³ /h									Diámetro	
							HP	KW	II 230	III 230	III 400	0	0,6	0,7	0,9	1,2	1,5
		Altura m.c.a. / Height w.c.m.															
PE 38-M	8	0,50	0,37	2,9	-	-	42	33	30	27	23	18	11	2,5		1"	1"
PE 60-M	20	1	0,75	5,2	-	-	65	56	53	51	48	44	37	31	18	1"	1"
PE 60-T	-			-	3,4	2,2											



Serie Pico



Serie SELTZ L



■ **Aplicaciones:**

Electrobomba sumergida para pequeñas aplicaciones como pueden ser: Acuarios, fuentes, surtidores, refrigeración de máquinas de corte, etc...

Bombas aptas para trabajos con agua salada. Ideales para uso intermitente o bien continuo provistas de regulación de caudal, para adaptarlas a diferentes aplicaciones y usos.

Voltaje 230 V, 50 Hz.

■ **Serie Pico:**

Excepcionales prestaciones hidráulicas con bajo consumo eléctrico. Puede trabajar con muy pocos centímetros de nivel de agua.

■ **Serie SELTZ L:**

Incluyen cartucho filtrante en la aspiración. Pueden trabajar sin estar sumergidas mediante el uso de los racores proporcionados de serie.

■ **Características Constructivas:**

Turbina patentada uni-direccional y compacta, amortiguador de gran poder de absorción, contruidos con materiales anti-corrosivos y resistentes a agentes químicos para diversas aplicaciones industriales.

■ **Applications:**

Submersible electropumps for small applications, such as: aquariums, fountains, jets, cooling cutting machines, etc.

Pumps suitable for work with salt water. Ideal for intermittent or continuous use. Adjustable water flow.

Voltage 230 V, 50 Hz.

■ **Pico Series:**

Exceptional hydraulic performance with low energy consumption.

■ **SELTZ L Series:**

Includes filter sponge. *Equipped with tube connectors for non submerged use.*

■ **Construction:**

Single direction, compact patented impeller, highly absorbent damper, built using rustproof materials able to withstand chemical agents, for a variety of industrial applications.

Tipo Type	ALTURA MÁXIMA MAX. HEIGHT	CAUDAL MÁXIMO MAX. FLOW	CONSUMO WATT CONSUMPTION W.
PICO EVOLUTION 400	70 cm	385 l/h	4
PICO EVOLUTION 1200	70 cm	1.120 l/h.	7

Tipo Type	ALTURA MÁX. MAX. HEIGHT	CAUDAL MÁX. MAX. FLOW	CONSUMO W. CONSUMPTION W.	Ø SALIDA Ø Hose	Largo Length	Ancho Width	Alto Height
SELTZ L 20	135 cm	700 l/h.	14	12 mm	9,6 mm	5 mm	8,3 mm
SELTZ L 30	195 cm	1.200 l/h.	27	12 mm	12,7 mm	6,5 mm	10,8 mm
SELTZ L 40	230 cm	2.800 l/h.	55	16 mm	16,5 mm	8,9 mm	12,7 mm



NOVABOX



■ Aplicaciones:

SERIE NOVA: Electrobomba sumergible doméstica que por su forma compacta y manejable es ideal para su uso fijo y portátil. Bomba idónea para achique de filtraciones en bodegas, garajes, sótanos, vaciado de piscinas, etc.

SERIE FEKA: Electrobomba sumergible doméstica está preparada para elevar aguas cargadas con cuerpos sólidos en suspensión de hasta 25 mm.

El interruptor de boya de las dos series permite la instalación fija y garantiza el funcionamiento automático de la bomba.

NOVABOX: Estación elevadora automática de aguas ligeramente cargadas domésticas procedentes de bañeras, lavabos, duchas y lavaderos situados en semisótanos o bien por debajo del nivel de la red de alcantarillado. Está construido por una electrobomba **Nova 300 M aut.** con 5mts. de cable y enchufe instalado en un contenedor de tecnopolímero con una capacidad de 30 litros y una válvula antirretorno en la impulsión. La estación de elevación se entrega con una bomba ya ensamblada y lista para su funcionamiento totalmente automático.

■ Características constructivas:

Cuerpo bomba, turbina y filtro de aspiración en tecnopolímero hidrorresistente, tornillería y eje en acero inoxidable, triple cierre mecánico y anillo separador con cámara de aire.

■ Motor:

Sumergible, asíncrono. El estator está dentro de una cámara hermética de acero inoxidable. Protección termo-amperimétrica y condensador fijo incorporado en versiones monofásicas.

Grado de protección IP-68. Aislamiento clase F.

Incluye 5 metros de cable.

TEMPERATURA MÁXIMA DEL AGUA: 40° C.

INMERSION MÁXIMA: 7 mts.

■ Applications:

NOVA SERIES: A submersible domestic electropump, whose compact, easy-to-handle form is ideal for its fixed and portable use. The ideal pump for baling filtrations in cellars, garages, basements, emptying pools, etc.

FEKA SERIES: A submersible domestic electropump to raise large loads with solid bodies up to 25 mm in suspension. The floating switch in the two series allows fixed installation and guarantees the automatic working of the pump.

NOVABOX: An automatic raising station for lightly loaded household waters from baths, washbasins, showers and washers in semi basements or below the drainage network. It comprises a **Nova 300 M aut.** Electropump, with 5 metres of cable and a switch installed in a 30 litre techno polymer container and a non return valve in the drive. The raising station is delivered with a pump already assembled and ready for fully automated working.

■ Construction:

Pump body, impeller and suction filter in water-resistant techno polymer, bolts and shaft in stainless steel. Triple mechanical seal and separator ring with air chamber.

■ Motor:

Submersible, asynchronous. The stator is inside a sealed chamber in stainless steel. Thermo-amperimetric protection and fixed capacitor built in to single phase versions.

IP-68 protection. Class F insulation.

Includes 5 meters of electric wire.

MAXIMUM WATER TEMPERATURE: 40° C.

MAXIMUM IMMERSION: 7 metres.

Tipo Type	Cond. µF	Potencia		"A"		Caudal m ³ /h / Flow m ³ /h											Diámetro	
		HP	KW	II 230	III 400	0	1,2	2,4	3,6	4,5	6	7,5	9	12	15	16	IMP.	Paso Sólido
						Altura m.c.a. / Height w.c.m.												
NOVA 180 M NOVA 180 M AUT.	5	0,3	0,22	0,9	-	4,8	4,2	3,5	2,4	1,4							1"	5 mm.
NOVA 200 M NOVA 300 M AUT.	8	0,3	0,22	1,5	-	6,8	6,7	6	5,6	5,1	4,6	4	3,4	2,2			1 1/4"	5 mm. 10 mm.
NOVA 600 M NOVA 600 M AUT. NOVA 600 T	14 - -	0,75	0,55	3,4 - 1,6	-	10,2	9,5	9,1	8,7	8,3	7,8	7,2	6,6	5	3,1	2,2	1 1/4"	10 mm.
FEKA 600 M FEKA 600 M AUT. FEKA 600 T	14 - -	0,75	0,55	4,3 - 1,7	-	7,5	7	6,6	6,3	6,1	5,7	5,4	4,9	4,1	2,8	2,2	1 1/4"	25 mm.

Sumergibles de Achique inoxidable Serie "DRENOX"



D

■ Aplicaciones:

Electrobombas sumergibles aptas para el drenaje de aguas procedentes de filtraciones, evacuación de aguas pluviales, vaciado de pozos o piscinas, riego de huertos o jardines, aplicaciones industriales, etc...

■ Características constructivas:

La Serie Drenox está construida íntegramente en acero inoxidable (excepto Drenox 7 que incorpora turbina en Noryl). La perfecta refrigeración del motor permite aspirar agua hasta 13 mm. del suelo, permitiendo trabajar a la bomba sin estar sumergida totalmente.

La protección contra la arena, protege al cierre mecánico de la abrasión.

■ Motor:

Termoprotectado, aislamiento tipo F, cámara de conexiones aislada totalmente.

Doble sello mecánico, lubricado mediante una pequeña cámara de aceite.

Incluye 10 metros de cable.

■ Applications:

Submersible electropumps suitable for draining waters from filtrations, evacuation of rainwater, emptying wells or pools, irrigation of vegetable gardens, industrial applications, etc.

■ Construction:

The Drenox Series is built entirely in stainless steel (except for Drenox 7, which includes a Noryl impeller).

The perfect cooling of the motor allows water to be taken up to 13 mm from the floor and the pump may work without being totally submerged.

The sand protection prevents the mechanical seal from being damaged.

■ Motor:

Thermoprotected, Type F insulation, junction box totally insulated. Double mechanical seal, lubricated by a small oil chamber.

Includes 10 meters of electric wire.

Tipo Type	Cond. μF	Potencia		"A"	Caudal m ³ /h / Flow m ³ /h								Ø IMP.	
		HP	KW		0,6	2,4	3,6	4,8	7,2	9,6	14	18		
					Altura m.c.a. / Height w.c.m.									
DRENOX 7 DRENOX 7 AUT.	6,3	0,3	0,2	1,1	6,5	4	2							1 1/4"
DRENOX 8 DRENOX 8 AUT.	8	0,5	0,37	2,2	7	6	5	4	2,2					1 1/4"
DRENOX 10 DRENOX 10 AUT.	8	0,75	0,55	3,5	9,4	8,5	7,6	7,2	5	4				1 1/4"
DRENOX 12 DRENOX 12 AUT.	12,5	1	0,75	5,1	11	10	9,5	9	7	6	3	1		1 1/4"

Serie "OPTIMA"	56
Serie "WINNER"	57
Serie "MAGNUS"	58
Serie "KONTRA"	59
Serie "CF-2" a 2.850 r.p.m.	60
Serie "VERT CF-2" a 2.850 r.p.m.	61
Serie "CF-4" a 1.450 r.p.m.	62
Serie "VERT CF-4" a 1.450 r.p.m.	63
Serie "BR-2" a 2.850 r.p.m.	64
Serie "ACF"	65
Serie "Poolmatic"	66
Soplantes	67
Prefiltros Suelos	68
Prefiltros Suelos Inox.	69
Kit de Filtración bomba + filtro	70
Filtros Soplados Válvula Lateral	71
Filtros Domésticos	72
Filtros para Piscina Pública	73
Serie "PL" Dosificadoras	74



■ Aplicaciones:

Bomba autoaspirante para piscinas con prefiltro incorporado que junto a las excelentes prestaciones hidráulicas que ofrece, genera una altísima capacidad de filtración. Filtro con tapa transparente que permite observar fácilmente el interior del prefiltro. Cesto prefiltro de grandes dimensiones. Imposibilidad de comunicación eléctrica con el agua, ya que ninguna parte del motor está en contacto con el líquido bombeado.

Especialmente adecuada para trabajo con agua de mar.

■ Dos posibilidades de conexión:

- Conexión rosca hembra de 1 1/2"
- Conexión para tubo de PVC de Ø 50 para encolar.
(Se suministran los enlaces rápidos)

■ Características constructivas:

Cuerpo bomba y difusor en polipropileno resistente a los productos químicos de las piscinas y reforzado con fibra de vidrio garantizando una excelente duración. Turbina en Noryl. Tapa transparente en policarbonato con sistema de cierre mediante pomos. Sello mecánico en AISI-316 y partes de roce en carbón-cerámica, eje en acero inoxidable AISI-316, tornillería en acero inoxidable AISI-304. Soporte bomba en aluminio.

■ Motor:

Motor asíncrono, cerrado de ventilación externa. Grado de protección IP-55, a 2.850 r.p.m. y 50 Hz (60 Hz bajo demanda). Aislamiento clase F. Rodamientos del motor lubricados de por vida y seleccionados para garantizar larga duración y silenciosidad.

TEMPERATURA MAXIMA DEL AGUA: 40° C.

■ Applications:

Self priming pump for swimming pools with a large pre-filter, which together with its excellent hydraulic performance, generates a very large filtering capacity. A filter with a transparent polycarbonate lid that easily allows inspection of the interior of the pre-filter basket. Large dimensions pre-filter basket. No possible electrical communication with the water as no part of the motor is in contact with the water.

Specially suitable for work with sea water.

■ Two possibilities for the connection of the pipes:

- Female threat Ø 1 1/2"
- PVC glue connections Ø 50
(Fast PVC connectors are supplied with the pump)

■ Constructive Characteristics:

Pump body and diffuser in polypropylene, resistant to the chemical products in pools and reinforced with fiber glass, guaranteeing excellent duration. Noryl impeller. Support in aluminum. Mechanical seal in AISI-316 and carbon-ceramic. Shaft in Stainless Steel AISI 316. Bolts in AISI 304.

■ Motor:

Electrical asynchronous motor, close with external ventilation. Protection IP-55. 2,850 r.p.m. 50 Hz. (60Hz. Under demand). Class F insulation. Motor bearings greased for life and selected to ensure long duration and silent work.

MAXIMUM WATER TEMPERATURE: 40° C.

Tipo Type	HP	KW	Cond. µF	"A"			Altura m.c.a. / Height w.c.m.						Ø ASP.	Ø IMP.
				II	III	III	4	6	8	10	12	14		
				230	230	400	Caudal m³/h / Flow m³/h							
OPTIMA 25 M	0,25	0,16	18	3,4	-	-	10	8	6	4	0,5	-	1 1/2" ø ø 50PVC	1 1/2" ø ø 50PVC
OPTIMA 33 M	0,33	0,25	18	3,4	-	-	12	10	8	5,5	2	-		
OPTIMA 50 M	0,5	0,33	18	3,5	-	-	14	12	10	7	5	-		
OPTIMA 75 M/T	0,75	0,55	20/-	4,3	3	1,7	16	15	12,5	10	8	4,2		
OPTIMA 100 M/T	1	0,75	20/-	5,5	3,4	2	18	16	15,3	13	10,5	7,6		

**PARA MAS INFORMACION CONSULTAR NUESTRO CATALOGO TECNICO DE BOMBAS DE PISCINAS
CHECK OUR TECHNICAL CATALOGUE OF SWIMMING POOL PUMPS FOR MORE INFORMATION**

Autoaspirante para Piscinas

Serie "WINNER"



■ Aplicaciones:

Electrobomba autoaspirante para piscinas, con prefiltro incorporado de grandes dimensiones, lo que genera una altísima capacidad de filtración.

Filtro con tapa transparente en policarbonato que permite observar fácilmente el interior del cesto prefiltro.

Imposibilidad de comunicación eléctrica con el agua, ya que ninguna parte del motor tiene contacto con el agua.

■ Características constructivas:

Cuerpo bomba, tapa cuerpo bomba, base y difusor en polipropileno, resistente a los productos químicos de las piscinas y reforzado con fibra de vidrio garantizando una excelente duración. Turbina en Noryl. Eje en acero inoxidable AISI 316. Sello mecánico en AISI-304 y partes de roce en carbón-cerámica (bajo demanda AISI-316 para agua de mar). Conexión de aspiración e impulsión a 2".

■ Motor:

Motor asíncrono, cerrado de ventilación externa. Grado de protección IP-55. 2.850 r.p.m. 50 Hz (60 Hz bajo demanda excepto WINNER 300 M). Aislamiento clase F.

TEMPERATURA MAXIMA DEL AGUA: 40° C.

* Incorpora de serie llave para apertura de la tapa prefiltro sin esfuerzos.

* Includes an easy open key.



■ Applications:

A self-priming pump for pools with a large prefilter to generate a very high filtration capacity. A filter with a transparent Polycarbonate lid to be able to easily see the interior of the prefilter basket. No possible electric contact with the water as no part of the motor is in contact with it.

Large volume pre-filter basket to be able to offer high quality filtering and not require the basket to be cleaned constantly when the pool is excessively dirty. Pre-filter lid key supplied standard with each pump, which allows effortless lid opening and great comfort as it is possible to hold it with both hands.

■ Construction:

Pump body, pump body lid, base and diffuser in polypropylene, resistant to the chemical products present in pools and reinforced with glass fibre to ensure excellent duration. Impeller in Noryl. Shaft in stainless steel AISI-316. Mechanical seal in AISI-304 and carbon ceramic (AIS-316 for sea water under demand). Connection to 2" suction and drive".

■ Motor:

Sealed asynchronous with external ventilation. IP-55 protection, 2,850 rpm, 50 Hz. Class F insulation.

MAXIMUM WATER TEMPERATURE: 40° C.

Tipo Type	HP	KW	Cond. µF	"A"			Altura m.c.a. / Height w.c.m.									Ø ASP.	Ø IMP.	
				II 230	III 230	III 400	4	6	8	10	12	14	16	18	21			
													Caudal m³/h / Flow m³/h					
WINNER 50 M WINNER 50T	0,5	0,37	16	3,6	-	-	17,5	15,6	13,5	11,1	8,4						2"	2"
WINNER 75 M WINNER 75T	0,75	0,55	20	4,75	-	-	19,5	19	15,7	13,5	10,8	7,9					2"	2"
WINNER 100 M WINNER 100T	1	0,75	25	5,5	-	-	23,2	21	19,7	18	15	12,3	8,7				2"	2"
WINNER 150 M WINNER 150T	1,5	1	30	7,3	-	-	27,7	26	24	21	19	17	13	10			2"	2"
WINNER 200 M WINNER 200T	2	1,5	40	9,2	-	-		29	26	24	21	18	14	12			2"	2"
WINNER 300 M WINNER 300T	3	2,2	40	12,2	-	-		33	31	29	27	23	20	15	12		2"	2"

**PARA MAS INFORMACION CONSULTAR NUESTRO CATALOGO TECNICO DE BOMBAS DE PISCINAS
CHECK OUR TECHNICAL CATALOGUE OF SWIMMING POOL PUMPS FOR MORE INFORMATION**



**1.450 r.p.m.
de 3 a 10 HP**



Kit contra bridas y tornillos disponible bajo demanda
Flanges and bolts kit available under demand

■ Aplicaciones:

Bomba extremadamente silenciosa dado que gira a 1.450 rpm hasta 10CV.

Bomba autoaspirante de gran caudal con motores de 1.450rpm y 2.850 rpm ideal para grandes equipos de filtración. Incorpora un prefiltro en la aspiración de grandes dimensiones, que junto a las excelentes prestaciones hidráulicas que ofrece, genera una altísima capacidad de filtración.

Filtro con tapa transparente en policarbonato que permite observar fácilmente el interior del cesto prefiltro.

Imposibilidad de comunicación eléctrica con el agua, ya que ninguna parte del motor tiene contacto con el líquido bombeado.

Posibilidad de trabajo con agua de mar aplicando un suplemento de sello mecánico en AISI-316.

■ Características Constructivas:

Cuerpo Prefiltro, Cuerpo bomba, Voluta, Base y Tapa cuerpo bomba en polipropileno resistente a los productos químicos de las piscinas, y reforzado con fibra de vidrio. Cesto prefiltro en polietileno. Rodete en Noryl ó Bronce. Tapa prefiltro en policarbonato con sistema de cierre con cuatro pomos. **Rodete de Noryl en MAGNUS-4 300 y 400. Rodete de Noryl o Bronce en MAGNUS-4 550, 750 y 1000. Rodete de Bronce en MAGNUS-2 1250 y 1500.** Cierre mecánico en carbón cerámica y acero inoxidable AISI 304. Tornillería en acero inoxidable AISI 304. Eje en acero inoxidable AISI 316.

■ Motor:

Motor asincrónico cerrado de ventilación externa. Grado de protección IP-55. Aislamiento clase F. 1.450 rpm y 2.850 rpm. Doble frecuencia 50 Hz y 60 Hz. Rodamientos engrasados de por vida, garantizando una larga duración y un trabajo silencioso.

■ Applications:

Extremely silent pump, at 1,450 rpm until 10HP

High flow self priming pump with motors at 1.450 rpm & 2.850 rpm, designed for big filtration installations. Equipped with a big capacity strainer in the inlet that among its excellent performance generates a high filtration capacity. Prefilter with a transparent lid that allows easy inspection of the basket. No possible electrical contact with the water as no part of the motor is open to it.

This range is capable of working with sea water just by installing a Stainless Steel AISI-316 mechanical seal.

■ Constructive Characteristics:

Prefilter, Pump body, Voluta, Base & pump body lid in polypropylene resistant to Chemicals products used in pool and sand reinforced with fiber glass. Prefilter basket in polyethylene. Strainer lid in polycarbonate with a closing system using four handles. **Noryl impeller in MAGNUS-4 300 & 400. Noryl or Bronze impeller in MAGNUS-4 550, 750 & 1000. Bronze impeller in MAGNUS-2 1250 & 1500.** Mechanical seal in carbon-ceramic & stainless steel AISI 304. Nuts and bolts in stainless steel AISI 304. Shaft in stainless steel AISI 316.

■ Motor:

Standard Asynchronous motor, sealed with external ventilation. Protection IP-55. Isolation class F. 1,450 rpm & 2,850 rpm. Double frequency 50Hz y 60 Hz. Motor bearings greased for life and selected to ensure long duration and silent working.

Tipo Type	Potencia		"A"			r.p.m.	Altura m.c.a. / Height w.c.m.												Diámetro	
	HP	KW	III 230	III 400	III 690		6	8	10	12	14	16	18	20	22	24	ASP	IMP		
							Caudal m ³ /h / Flow m ³ /h													
Magnus-4 300	3	2,2	9,4	5,3	-	1.450	63	53	43	30	16							110	110	
Magnus-4 400	4	3	12,5	6,9	-	1.450	72	64	56	46	35	20						110	110	
Magnus-4 550	5,5	4	15,3	8,8	-	1.450	115	96	79	52	20							110	110	
Magnus-4 750	7,5	5,5	-	12	7	1.450	136	121	101	83	59	26						110	110	
Magnus-4 1000	10	7,5	-	15,8	9,2	1.450	156	146	126	108	88	61	30					110	110	
Magnus-2 1250	12,5	9,2	-	18,5	10,7	2.850	191	182	165	146	132	115	102	76	43			110	110	
Magnus-2 1500	15	11	-	20,9	12	2.850	203	194	181	171	158	145	130	120	100	80		110	110	

Centrífugas y Natación Contra Corriente

Serie "KONTRA"

Boquilla Natación
Contra Corriente
para 3, 4 y 5,5 HP
(Se suministra bajo
demanda)



**1.450 r.p.m.
de 3 a 10 HP**

Kit contra bridas y tornillos disponible bajo demanda
Flanges and bolts kit available under demand



Aplicaciones:

Bomba extremadamente silenciosa dado que gira a 1.450 rpm hasta 10CV.

Bomba centrífuga que gracias al gran caudal que genera a bajas presiones, la hace idónea para muchos tipos de instalaciones, como instalaciones de refrigeración, trasvase, etc... Imposibilidad de comunicación eléctrica con el agua, ya que ninguna parte del motor tiene contacto con el líquido bombeado.

Posibilidad de trabajo con agua de mar aplicando un suplemento de sello mecánico en AISI-316.

Características Constructivas:

Cuerpo bomba, Voluta, Base y Tapa cuerpo bomba en polipropileno resistente a los productos químicos de las piscinas, y reforzado con fibra de vidrio. **Rodete de Noryl en KONTRA-4 300 y 400. Rodete de Noryl o Bronce en KONTRA-4 550, 750 y 1000. Rodete de Bronce en KONTRA-2 1250 y 1500.** Cierre me-cánico en carbón cerámica y acero inoxidable AISI 304. Tornillería en acero inoxidable AISI 304. Eje en acero inoxidable AISI 316.

Motor:

Motor asíncrono cerrado de ventilación externa. Grado de protección IP-55. Aislamiento clase F. 1.450 rpm y 2.850 rpm. Doble frecuencia 50 Hz y 60 Hz. Rodamientos engrasados de por vida, garantizando una larga duración y un trabajo silencioso.

Applications:

Extremely silent pump, at 1,450 rpm until 10HP

Centrifugal pumps with a high flow capacity generated at low pressure, makes it the ideal pumps for a lot of types of installations like cooling installations, big transfers, etc... No possible electrical contact with the water as no part of the motor is open to it.

This range is capable of working with sea water just by installing a Stainless Steel AISI-316 mechanical seal.

Constructive Characteristics:

Pump body, Volut, Base & pump body lid in polypropylene resistant to Chemicals products used in pools and reinforced with fiber glass. Strainer lid in polycarbonate with a closing system using four handles. **Noryl impeller in KONTRA-4 300 & 400. Noryl or Bronze impeller in KONTRA-4 550, 750 & 1000. Bronze impeller in KONTRA-2 1250 & 1500.** Mechanical seal in carbon-ceramic & stainless steel AISI 304. Nuts and bolts in stainless steel AISI 304. Shaft in stainless steel AISI 316.

Motor:

Standard Asynchronous motor, sealed with external ventilation. Protection IP-55. Isolation class F, 1,450 rpm y 2,850 rpm. Double frequency 50 Hz y 60 Hz. Motor bearings greased for life and selected to ensure long duration and silent working.

Tipo Type	Potencia		"A"				r.p.m.	Altura m.c.a. / Height w.c.m.										Diámetro ASP. IMP			
			III	III	III			6	8	10	12	14	16	18	20	22	24				
	HP	KW	230	400	690		Caudal m ³ /h / Flow m ³ /h														
Kontra-4 300	3	2,2	9,4	5,3	-	1.450	63	53	43	30	16									110	110
Kontra-4 400	4	3	12,5	6,9	-	1.450	72	64	56	46	35	20								110	110
Kontra-4 550	5,5	4	15,3	8,8	-	1.450	115	96	79	52	20									110	110
Kontra-4 750	7,5	5,5	-	12	7	1.450	136	121	101	83	59	26								110	110
Kontra-4 1000	10	7,5	-	15,8	9,2	1.450	156	146	126	108	88	61	30							110	110
Kontra-2 1250	12,5	9,2	-	18,5	10,7	2.850	191	182	165	146	132	115	102	76	43					110	110
Kontra-2 1500	15	11	-	20,9	12	2.850	203	194	181	171	158	145	130	120	100	80				110	110



■ Aplicaciones:

Bomba centrífuga de gran caudal con motor a 2.850 r.p.m., que incorporan un prefiltro en la aspiración, lo cual hace de ellas la bomba ideal para grandes equipos de filtración.

■ Características constructivas:

Cuerpo bomba, soporte, prefiltro, acoplamiento y turbina en fundición de hierro de alta calidad con un pretratamiento de pintura epoxi-poliéster y secado al horno para darle más durabilidad y resistencia a la oxidación, sello mecánico en cerámica carbón, eje y cesto prefiltro en acero inoxidable AISI-316. Bombas monobloc que equipan un motor normalizado a través de un acoplamiento eje-bomba motor.

Bajo demanda pueden suministrarse con turbina de bronce.

■ Motor:

Motor asíncrono standard, cerrado de ventilación externa, apto para trabajo continuo.

Grado de protección IP-55. Aislamiento clase F (calentamiento "B") tropicalizados a 2.850 r.p.m. 50 Hz y bajo demanda 60 Hz y otras tensiones.

■ Applications:

A large volume centrifugal pump, to which a pre-filter has been applied in the inlet, making these the ideal pumps for large filtering units for swimming pools.

■ Constructive Characteristics:

Pump body, pre-filter, coupling and impeller in cast iron. Shaft and pre-filter basket in AISI 316 stainless steel. Mechanical seal in carbon-ceramic. On request, the impeller may be in bronze and the mechanical seal in silicon carbide or tungsten carbon.

■ Motor:

Standard asynchronous motor, sealed from external ventilation. **Its standard construction allows it to be replaced with another standard motor at any time and in any place. Protection IP-54. 2,850 rpm. 50-60 Hz.**

Another advantage, is that totally standard spare motors are available anywhere in the world, at any time and of any brand.

Tipo Type	HP	KW	R.P.M	"A"		Altura m.c.a. / Height w.c.m.											Ø ASP.	Ø IMP.
				230 V	400 V	6	8	10	12	14	16	18	20	22				
				Caudal m³/h / Flow m³/h														
CF-2 300	3	2,2	2.850	9	5,2	61	54	51	46	35	29						DN 80	DN 80
CF-2 400	4	3	2.850	12	6,9	70	64	59	55	49	42	30					DN 80	DN 80
CF-2 550	5,5	4	2.850	16,5	9,5	95	90	84	77	66	54	32					DN 125	DN 100
CF-2 551	5,5	4	2.850	16,5	9,5	128	121	107	90	69	30						DN 125	DN 100
CF-2 750	7,5	5,5	2.850	21,7	12,5	159	152	135	125	109	88	60					DN 125	DN 100
CF-2 1000	10	7,5	2.850	-	15,5	175	166	158	147	135	119	98	68				DN 125	DN 100
CF-2 1250	12,5	9,2	2.850	-	19	195	188	175	163	150	136	105	86				DN 125	DN 100
CF-2 1500	15	11	2.850	-	23	200	197	193	183	170	155	132	110	87			DN 125	DN 100

En los modelos de 3 y 4 CV recomendamos la instalación con tubo de 90 mm. (For 3-4 HP we recommend minimum 90 mm. pipe)

* Voltaje de Serie 400/690 V (bajo demanda 230/400 V) / * Standard voltage 400/690 V (under demand 230/400 V)

**PARA MAS INFORMACION CONSULTAR NUESTRO CATALOGO TECNICO DE BOMBAS DE PISCINAS
CHECK OUR TECHNICAL CATALOGUE OF SWIMMING POOL PUMPS FOR MORE INFORMATION**

Centrífugas con Prefiltro para Piscinas a 2.850 r.p.m. Serie "VERT CF-2"



■ Aplicaciones:

Bomba centrífuga de gran caudal con motor a 2.850 r.p.m., que incorporan un prefiltro en la aspiración, lo cual hace de ellas la bomba ideal para grandes equipos de filtración.

■ Características constructivas:

Cuerpo bomba, soporte, acoplamiento y turbina en fundición de hierro de alta calidad con un pretratamiento de pintura epoxi-poliéster y secado al horno para darle más durabilidad y resistencia a la oxidación, sello mecánico en cerámica-carbón, **eje y prefiltro para montaje vertical en acero inoxidable AISI-316**. Bombas monobloc que equipan un motor normalizado a través de un acoplamiento eje-bomba motor. **Bajo demanda pueden suministrarse con turbina de bronce.**

■ Motor:

Motor asíncrono standard, cerrado de ventilación externa, apto para trabajo continuo. Grado de protección IP-55. Aislamiento clase F (calentamiento "B") tropicalizados a 2.850 r.p.m. 50 Hz y bajo demanda 60 Hz y otras tensiones.

■ Applications:

A large volume centrifugal pump, to which a pre-filter has been applied in the inlet, making these the ideal pumps for large filtering units for swimming pools.

■ Constructive Characteristics:

Pump body, pre-filter, coupling and impeller in cast iron. **Shaft and pre-filter for vertical installation in AISI-316 stainless steel.** Mechanical seal in carbon-ceramic. On request, the impeller may be in bronze and the mechanical seal in silicium-carbide or tungsten-carbon. **Under demand we can provide these pumps with bronze impeller.**

■ Motor:

Standard asynchronous motor, sealed from external ventilation. Its standard construction allows it to be replaced with another standard motor at any time and in any place. Protection IP-55. 2,850 rpm. 50-60Hz. Another advantage, is that totally standard spare motors are available anywhere in the world, at any time and of any brand.

Tipo Type	HP	KW	R.P.M	"A"		Altura m.c.a. / Height w.c.m.										Ø ASP.	Ø IMP.
				230 V	400 V	6	8	10	12	14	16	18	20	22			
Caudal m ³ /h / Flow m ³ /h																	
VERT CF-2 300	3	2,2	2.850	9	5,2	61	54	51	46	35	29					DN 100	DN 80
VERT CF-2 400	4	3	2.850	12	6,9	70	64	59	55	49	42	30				DN 100	DN 80
VERT CF-2 550	5,5	4	2.850	16,5	9,5	95	90	84	77	66	54	32				DN 150	DN 100
VERT CF-2 551	5,5	4	2.850	16,5	9,5	128	121	107	90	69	30					DN 150	DN 100
VERT CF-2 750	7,5	5,5	2.850	21,7	12,5	159	152	135	125	109	88	60				DN 150	DN 100
VERT CF-2 1000	10	7,5	2.850	-	15,5	175	166	158	147	135	119	98	68			DN 150	DN 100
VERT CF-2 1250	12,5	9,2	2.850	-	19	195	188	175	163	150	136	105	86			DN 150	DN 100
VERT CF-2 1500	15	11	2.850	-	23	200	197	193	183	170	155	132	110	87		DN 150	DN 100

**PARA MAS INFORMACION CONSULTAR NUESTRO CATALOGO TECNICO DE BOMBAS DE PISCINAS
CHECK OUR TECHNICAL CATALOGUE OF SWIMMING POOL PUMPS FOR MORE INFORMATION**



■ Aplicaciones:

Bomba centrífuga de gran caudal con motor a 1.450 r.p.m., que incorporan un prefiltro en la aspiración, lo cual hace de ellas la bomba ideal para grandes equipos de filtración. El hecho de que la bomba funcione con un motor de 1.450 r.p.m. la hace muy silenciosa y de larga durabilidad.

■ Características constructivas:

Cuerpo bomba, soporte, prefiltro y turbina en fundición de hierro. Eje-acoplamiento y cesto prefiltro en acero inoxidable. Cierre mecánico en carbón-carburo de silicio. Bombas monobloc que equipan un motor normalizado a través de un acoplamiento eje-bomba motor.

Bajo demanda pueden suministrarse con turbina de bronce.

■ Motor:

Motor asíncrono standard, cerrado de ventilación externa, apto para trabajo continuo.

Grado de protección IP-55. Aislamiento clase F (calentamiento "B") tropicalizados a 1.450 r.p.m. 50 Hz y bajo demanda 60 Hz y otras tensiones.

■ Applications:

A large volume centrifugal pump, to which a pre-filter has been applied in the inlet, making these the ideal pumps for large filtering units. The fact that the pump works with a 1,450 rpm. motor makes it very quiet and long lasting.

■ Constructive Characteristics:

Pump body, support, pre-filter and impeller in cast iron. Shaft-coupling and pre-filter sieve in AISI 316 stainless steel. Mechanical seal in carbon - silicium carbide. On demand the CF-4 pump range may be supplied with bronze impeller (standard in cast iron) or with other versions of mechanical seal, such as : tungsten carbon, aisi 316, epdm, viton etc...

■ Motor:

Standard asynchronous motor, sealed from external ventilation. Its standard construction allows it to be replaced with another standard motor at any time and in any place. Protection IP-55. 1,450 rpm. 50-60 Hz.

Estas bombas no equipan contrabridas de serie.

Tipo Type	HP	KW	R.P.M	"A"		Altura m.c.a. / Height w.c.m.										Ø ASP.	Ø IMP.	
						230 V 400 V		9	10	12	14	15	16	18	20			21
						Caudal m ³ /h / Flow m ³ /h												
CF-4 300	3	2,2	1.450	9,4	5,3	54	50	44	30	20							DN 65	DN 50
CF-4 400	4	3	1.450	12,5	6,9		70	67	50	36	20						DN 80	DN 65
CF-4 550	5,5	4	1.450	17	9,2			84	72	66	54	20					DN 80	DN 65
CF-4 552	5,5	4	1.450	17	9,2	120	110	78	28								DN 100	DN 80
CF-4 750	7,5	5,5	1.450	23	12			124	104	90	72						DN 100	DN 80
CF-4 1000	10	7,5	1.450	-	15,5		210	175	130	90	60						DN 125	DN 100
CF-4 1500	15	11	1.450	-	21,8			215	200	190	180	150	120	60			DN 125	DN 100
CF-4 2000	20	15	1.450	-	32			320	300	275	260	210	102				DN 150	DN 125
CF-4 2500	25	18,5	1.450	-	39				360	340	310	280	220	190			DN 150	DN 125

**PARA MAS INFORMACION CONSULTAR NUESTRO CATALOGO TECNICO DE BOMBAS DE PISCINAS
CHECK OUR TECHNICAL CATALOGUE OF SWIMMING POOL PUMPS FOR MORE INFORMATION**

Centrífugas con Prefiltro para Piscinas a 1.450 r.p.m. Serie "VERT CF-4"



■ Aplicaciones:

Bomba centrífuga de gran caudal con motor a 1.450 r.p.m., que incorporan un prefiltro en la aspiración, lo cual hace de ellas la bomba ideal para grandes equipos de filtración. El hecho de que la bomba funcione con un motor de 1.450 r.p.m. la hace muy silenciosa y de larga durabilidad.

■ Características constructivas:

Cuerpo bomba, soporte, y turbina en fundición de hierro. **Pre-filtro en acero inoxidable AISI-316 para montaje vertical.** Eje-acoplamiento y cesto prefiltro en acero inoxidable. Cierre mecánico en carbón-carburo de silicio. Bombas monobloc que equipan un motor normalizado a través de un acoplamiento eje-bomba motor.

Bajo demanda pueden suministrarse con turbina de bronce.

■ Motor:

Motor asíncrono standard, cerrado de ventilación externa, apto para trabajo continuo. Grado de protección IP-55. Aislamiento clase F (calentamiento "B") tropicalizados a 1.450 r.p.m. 50 Hz y bajo demanda 60 Hz y otras tensiones.

■ Applications:

A large volume centrifugal pump, to which a pre-filter has been applied in the inlet, making these the ideal pumps for large filtering units. **The fact that the pump works with a 1,450 rpm. motor makes it very quiet and long lasting.** Under demand we can provide these pumps with bronze impeller.

■ Constructive Characteristics:

Pump body, support, and impeller in cast iron. **Stainless steel AISI-316 pre-filter for vertical installation.** Shaft-coupling and pre-filter sieve in AISI 316 stainless steel. Mechanical seal in carbon - silicium carbide. On demand the CF-4 pump range may be supplied with bronze impeller (standard in cast iron) or with other versions of mechanical seal, such as: tungsten carbon, aisi316, epdm, viton etc...

■ Motor:

Standard asynchronous motor, sealed from external ventilation. It's standard construction allows it to be replaced with another standard motor at any time and in any place. Protection IP-55. 1,450 rpm. 50-60 Hz.

Estas bombas no equipan contrabridas de serie.

Tipo Type	HP	KW	R.P.M	"A"			Altura m.c.a. / Height w.c.m.										Ø ASP.	Ø IMP.	
				III 230 V	III 400 V	III 690 V	9	10	12	14	15	16	18	20	21				
				Caudal m ³ /h / Flow m ³ /h															
VERT CF-4 400	4	3	1.450	12,5	6,9	-		70	67	50	36	20						DN 100	DN 65
VERT CF-4 550	5,5	4	1.450	17	9,2	-				84	72	66	54	20				DN 100	DN 65
VERT CF-4 552	5,5	4	1.450	17	9,2	-	120	110	78	28								DN 125	DN 80
VERT CF-4 750	7,5	5,5	1.450	-	12	6,9				124	104	90	72					DN 125	DN 80
VERT CF-4 1000	10	7,5	1.450	-	15,5	8,9		210	175	130	90	60						DN 150	DN 100
VERT CF-4 1500	15	11	1.450	-	21,8	12,3				215	200	190	180	150	120	60		DN 150	DN 100
VERT CF-4 2000	20	15	1.450	-	32	18				320	300	275	260	210	102			DN 250	DN 125
VERT CF-4 2500	25	18,5	1.450	-	39	23,4				360	340	310	280	220	190			DN 250	DN 125

**PARA MAS INFORMACION CONSULTAR NUESTRO CATALOGO TECNICO DE BOMBAS DE PISCINAS
CHECK OUR TECHNICAL CATALOGUE OF SWIMMING POOL PUMPS FOR MORE INFORMATION**

E



■ Aplicaciones:

Bomba centrífuga en bronce marino de gran caudal con motor a 2.850 r.p.m., que incorporan un prefiltro en la aspiración, lo cual hace de ellas la bomba ideal para grandes equipos de filtración, especialmente en instalaciones con **agua de mar**.

■ Características constructivas:

Cuerpo bomba, soporte, prefiltro y turbina en bronce. Eje y cesto prefiltro en acero inoxidable AISI 316. Cierre mecánico en carbón-cerámica y acero inoxidable AISI 316. Bombas monobloc que equipan un motor normalizado a través de un acoplamiento eje-bomba motor.

■ Motor:

Motor asíncrono standard, cerrado de ventilación externa, apto para trabajo continuo.

Grado de protección IP-55. Aislamiento clase F (calentamiento "B") tropicalizados a 2.850 r.p.m. 50 Hz y bajo demanda 60 Hz y otras tensiones.

■ Applications:

A large volume centrifugal pump, to which a pre-filter has been applied in the inlet, making these the ideal pumps for large filtering units. The bronze version is ideal for sea water and automatic pool systems that use salt electrolysis as a means of disinfecting.

■ Constructive Characteristics:

Pump body, pre-filter, support and impeller DIN-1705 RG 5 bronze (G-CuSn 5 ZnPb). Shaft, pre-filter basket and bolts in AISI 316 stainless steel. Cast iron coupling. Mechanical seal in carbon-ceramic and AISI 316 stainless steel.

On request, these pumps may be supplied in any other bronze alloy.

■ Motor:

Standard asynchronous motor, sealed from external ventilation. **Its standard construction allows it to be replaced with another standard motor at any time and in any place. Protection IP-54. 2,850 rpm. 50-60 Hz.**

Tipo Type	HP	KW	R.P.M	"A"		Altura m.c.a. / Height w.c.m.										Ø ASP.	Ø IMP.
						Caudal m³/h / Flow m³/h											
				230 V	400 V	6	8	10	12	14	16	18	20	22			
BR-2 300	3	2,2	2.850	9	5,2	61	54	51	46	35	29					DN 80	DN 80
BR-2 400	4	3	2.850	12	6,9	70	64	59	55	49	42	30				DN 80	DN 80
BR-2 550	5,5	4	2.850	16,5	9,5	95	90	84	77	66	54	32				DN 125	DN 100
BR-2 551	5,5	4	2.850	16,5	9,5	128	121	107	90	69	30					DN 125	DN 100
BR-2 750	7,5	5,5	2.850	21,7	12,5	159	152	135	125	109	88	60				DN 125	DN 100
BR-2 1000	10	7,5	2.850	-	15,5	175	166	158	147	135	119	98	68			DN 125	DN 100
BR-2 1250	12,5	9,2	2.850	-	19	195	188	175	163	150	136	105	86			DN 125	DN 100
BR-2 1500	15	11	2.850	-	23	200	197	193	183	170	155	132	110	87		DN 125	DN 100

En los modelos de 3 y 4 CV recomendamos la instalación con tubo de 90 mm. (For 3-4 HP we recommend minimum 90 mm. pipe)

* Voltaje de Serie 400/690 V (bajo demanda 230/400 V) / * Standard voltage 400/690 V (under demand 230/400 V)

PARA MAS INFORMACION CONSULTAR NUESTRO CATALOGO TECNICO DE BOMBAS DE PISCINAS
CHECK OUR TECHNICAL CATALOGUE OF SWIMMING POOL PUMPS FOR MORE INFORMATION

Autoaspirante para Piscinas

Serie "ACF"

Aspiran hasta 6 mts.
sin válvula de pie.

6 mts. suction without
foot valve.

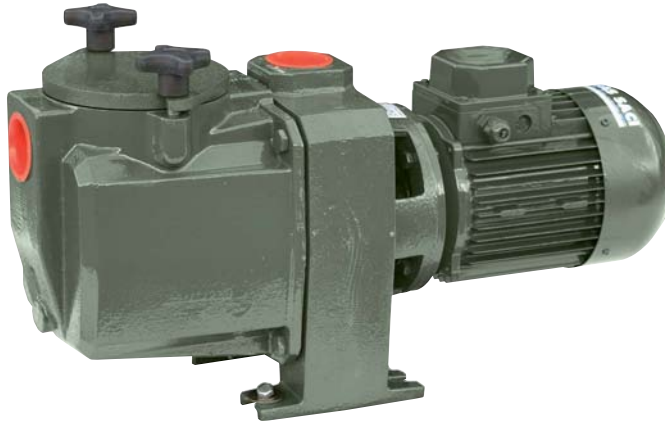

■ Aplicaciones:

Bomba de cebado automático, estando lleno el cuerpo de la bomba. Exenta de válvulas o mecanismos interiores que puedan dificultar el paso interior del líquido. Admite el trasvase de líquidos ligeramente turbios o arenosos. Adecuadas para el funcionamiento con **FILTROS DE PISCINA** por lo que se les ha incorporado un prefiltro de cabellos de fácil acceso para su limpieza.

■ Características constructivas:

Cuerpo bomba, soporte bomba y tapa prefiltro en fundición. Turbina abierta en latón y cesto prefiltro y eje en acero inoxidable. Cierre mecánico en cerámica-carbón.

■ Motor:

Asíncrono, cerrado de ventilación externa, grado de protección IP-54 a 2.850 r.p.m. 50 Hz. (Bajo demanda 60 Hz y otras tensiones).

■ Applications:

A self-priming pump, when the pump body is full. No valves or interior mechanisms to obstruct the interior passage of the liquid. It admits the transfer of liquids that are lightly turbid or sandy. Suitable for working with **POOL FILTERS**, and provided with a hair prefilter, easily accessible for cleaning.

Open brass impeller to allow the passage of liquids that are slightly turbid or have solid particles in suspension.

■ Construction:

Pump body, pump support and prefilter lid in cast iron. Open impeller in brass and prefilter basket and shaft in stainless steel. Mechanical seal in carbon ceramic.

■ Motor:

Sealed asynchronous with external ventilation. IP-54 protection at 2,850 rpm, 50 Hz. (60 Hz under demand).

Tipo Type	Con. µF	Potencia		"A"			Altura m.c.a. / Height w.c.m.											Diámetro	
							HP	KW	II 230	III 230	III 400	0	5	7	10	12	14	16	18
		Caudal m³/h / Flow m³/h																	
AC 1 - F M	14	0,5	0,37	3	-	-	9	8,5	7	6	5	3	1,5					1 1/2"	1 1/2"
AC 1 - FT	-			-	1,9	1,1													
AC 2 - F M	20	0,75	0,55	3,5	-	-	12	11,5	12	11	8	6	4	1,5				1 1/2"	1 1/2"
AC 2 - FT	-			-	2,77	1,6													
AC 3 - F M	25	1	0,75	4,8	-	-	18,5	18	15	14	13	11	8	4	1			1 1/2"	1 1/2"
AC 3 - FT	-			-	3	1,75													
AC 4 - F M	35	1,5	1,1	6	-	-	23	22	18	17	15	12	10	5	3	1		2"	2"
AC 4 - FT	-			-	4,5	2,6													
AC 5 - FT	-	2	1,5	-	6	3,5	27	26	23	19	17	14	12	8	4	1		2"	2"
AC 6 - FT	-	3	2,2	-	9	5,2	34	33	28	27	21	19	17	12	4	2		2"	2"

PARA MAS INFORMACION CONSULTAR NUESTRO CATALOGO TECNICO DE BOMBAS DE PISCINAS
CHECK OUR TECHNICAL CATALOGUE OF SWIMMING POOL PUMPS FOR MORE INFORMATION



■ Aplicaciones:

Bombas centrifugas multicelulares horizontales, extremadamente silenciosa especialmente concebida para trabajar con limpiafondos automáticos ya sea en piscinas con agua clorada como con agua tratada con electrolisis salina.

■ Características Constructivas:

Cuerpo bomba, turbinas y difusores en tecnopolimero, disco porta sello mecanico y eje en Acero Inoxidable AISI 316, cierre mecánico en carbon cerámica.

■ Motor:

Asincrono, cerrado de ventilación externa. Aislamiento clase F.

Maxima temperatura ambiente: 40° C

Maxima temperatura del agua: +40° C

■ Applications:

Multistage centrifugal pump, extremely silent a specially designed to work with automatic pool cleaners. This pump can be used rather with chlorinated water or with pools treated with salt electrolisis.

■ Construction:

Pump body, impellers & diffusers in techno polymer. Pump body lid and shaft in stainless steel AISI 316, mechanical seal in carbon ceramic.

■ Motor:

Asynchronous, close with external ventilation. Isolation type F, 2,850 rpm. 50Hz

Maximum ambient temperature: 40° C

Maximum water temperature: +40° C

Tipo Type	Con. µF	Potencia		"A"			Caudal m³/h / Flow m³/h								Diámetro		
		HP	KW	II 230	III 230	III 400	0	0,6	1,2	1,8	2,4	3	3,6	4,2	4,8	ASP.	IMP.
							Altura m.c.a. / Height w.c.m.										
POOLMATIC 30/50 M	12,5	0,75	0,55	3,9	-	-	42,2	40,25	38,2	36,2	33,8	30	24,8	19,5	14	1"	1"
POOLMATIC 30/50 T	-			-	2,8	1,6											
POOLMATIC 40/50 M	20	1	0,75	5,3	-	-	57,7	55,3	52,8	50,1	47,1	42,7	35,8	28	19,2	1"	1"
POOLMATIC 40/50 T	-			-	3,8	2,2											



■ Aplicaciones:

Bombas diseñadas para baños de burbujas y piscinas, tratamiento de aguas, secado de coches, ventilación/aspiración de polvo, etc...

■ Características constructivas:

Bombas soplantes construidas íntegramente en fundición de aluminio y adecuadas para el funcionamiento en continuo. Con turbinas de canal lateral de etapa simple, sin necesidad de ningún tipo de mantenimiento. Incorpora silenciadores tanto en la aspiración como en la impulsión.

■ Motor:

Asíncorno hermético de ventilación externa. Protección térmica incorporada.

Las versiones monofásicas incorporan condensador. Grado de protección IP-55. Aislamiento clase F.

■ Applications:

Pumps designed for bubble baths and swimming pools, water treatment, car drying, ventilation / dust extraction, etc ...

■ Constructive Characteristics:

Blower pumps constructed entirely in aluminum and suitable for continuous operation. Single stage side channel pumps, without any maintenance. Includes inlet and outlet silencers.

■ Motor:

Sealed asynchronous motor with external ventilation. Built-in thermal protection. Single phase versions includes capacitor. IP-55 protection. Isolation class F.

Tipo Type	Potencia		"A"			Caudal máximo Max. Flow (m ³ /h)	Max. Vacío / Pres. Max. ??? (mbar)	Nivel sonoro ??? (db)	Conexiones Connections	Aplicaciones Applications
	HP	KW	II 230	III 230	III 400					
HPE 80-400 M	0,6	0,4	2,7	-	-	80	-120/130	53	1 1/4"	1 Spa pequeño
HPE 80-400 T			-	2,6	1,5					
HPE 140-850 M	1,2	0,85	5	-	-	145	-160/160	63	1 1/2"	10 JETS
HPE 140-850 T			-	4,2	2,4					
HPE 140-131 M	1,8	1,3	7,3	-	-	145	-170/200	63	1 1/2"	10 JETS
HPE 140-131 T			-	6,6	3,8					
HPE 210-131 M	1,8	1,3	7,3	-	-	210	-170/170	64	2"	20 JETS
HPE 210-131 T			-	6,6	3,8					
HPE 210-151 M	2	1,5	9	-	-	210	-210/220	64	2"	20 JETS
HPE 210-161 T	2,2	1,6	-	7,5	4,3	210	-210/220	64	2"	20 JETS
HPE 315-221 T	3	2,2	-	10	5,8	318	-230/230	69	2"	30 JETS
HPE 315-301 T	4	3	-	12,5	7,2	318	-260/280	69	2"	30 JETS



■ Generalidades:

Bridas de entrada y salida según norma DIN 2501 con conexiones a partir de DN 65 (2 1/2") hasta DN 150 (6") provistos de 3-4 pomos de cierre (según modelos) para la perfecta estanqueidad de la tapa.

■ Características constructivas:

- **Versión fundición de hierro:**
- Vaso y tapa prefiltro en fundición de hierro con un pretratamiento de pintura epoxi-poliéster y secado al horno para darle más durabilidad y resistencia a la oxidación, con pomos y cesta en acero inoxidable AISI-316.
- **Versión bronce marino:**
- Vaso y tapa prefiltro en bronce DIN-1705 RG 5, pomos y cesto prefiltro en acero inoxidable AISI-316.

■ Generals:

Inlet and outlet clamps according to DIN 2501 with connections from DN 65 (2 1/2") to DN 150 (6") with 3-4 closing handles (depending on model) for a perfect lid seal.

■ Constructives characteristics :

- **Cast iron version:** Pot and pre-filter lid in cast iron. With epoxy-polyester paint. Prefilter basket and pre-filter handles in stainless steel AISI 316.
- **Bronze version:** Pot and pre-filter in marine bronze DIN 1705 RG 5. Basket-handles in stainless steel AISI 316.

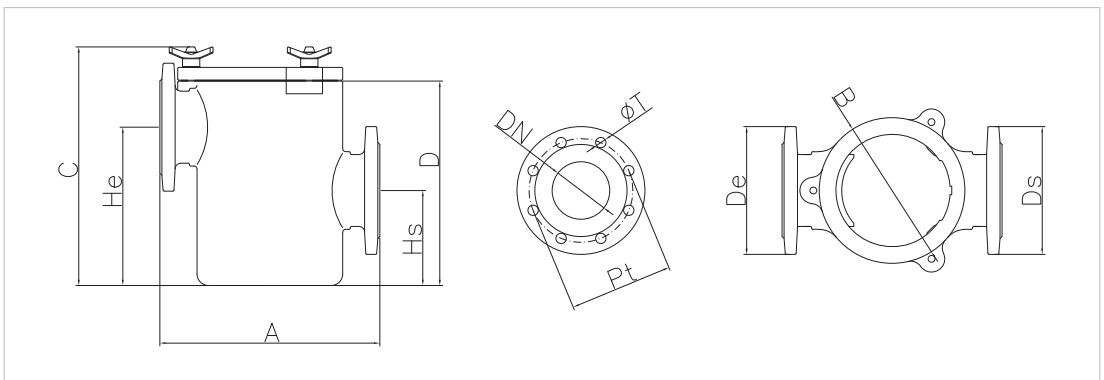

DIMENSIONES / DIMENSIONS

Tipo/Type	DN	Pt	A	B	C	D	De	He	Ds	Hs	ØT	Agujeros Holes
F 65/65	65	145	370	255	380	320	185	250	185	120	18	4
F 80/80	80	160	375	255	380	320	200	250	200	120	18	4-8
F 100/100	100	180	380	255	415	355	220	270	220	155	18	8
F 125/125	125	210	380	255	415	355	250	270	250	155	18	8
F 150/150	150	240	450	255	615	550	290	430	290	240	23	12

Prefiltros sueltos Inox

Serie "Prefiltros sueltos Inox"

Serie "Q"



Serie "N"

■ Aplicaciones:

Filtros íntegramente en acero inoxidable para conexión a bomba. Incorporan bridas norma DIN para fácil unión con bombas centrífugas. Disponen de un cesto también en acero inoxidable para evitar la entrada de partículas al interior de cuerpo bomba.

Existen diferentes modelos con diferentes bridas de unión para cada tipo de bomba (ver tabla según modelo).

■ Características constructivas:

Los filtros cilíndricos están contruidos íntegramente en acero inoxidable AISI-304, con boca de aspiración e impulsión a diferente altura. Disponen de tapa superior para acceder al filtro.

Los filtros cuadrados están contruidos íntegramente en acero inoxidable AISI-316, para montaje de bomba en vertical, lo cual ahorra mucho espacio. De aspiración horizontal e impulsión vertical para montar sobre la brida de aspiración de la bomba. Trampilla de fácil acceso al prefiltro para su limpieza.

■ Applications:

Filters of stainless steel to connect on pump. Equiped with DIN flanges for easy connection with pumps. Internal stainless steel basket to prevent particles from entering the pump body.

There are different models with different flanges for each type of pump (see table below).

■ Constructives characteristics:

Cylindrical filters are constructed of stainless steel AISI-304, with suction and discharge at different heights. They have top cover to access the strainer.

Square filters are constructed of stainless steel AISI-316, for vertical pump assembly, to save space in the installation. Suction horizontal and vertical drive to connect the suction of the pump. Hatch for easy access to strainer.

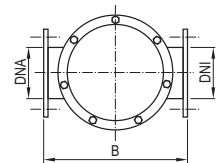
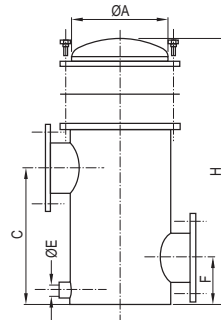
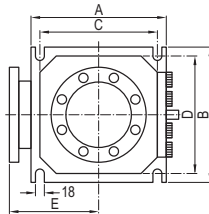
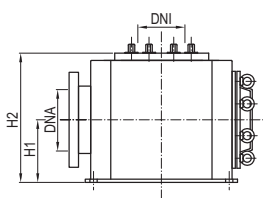

Tipo/Type	A	B	C	E	F	H	H1	H2	DNA	DNI	Vol. Lts.	Peso Kg. Weight Kg.
N 80/80	273	423	260	1/2"	110	400	-	-	80	80	23	28
N 100/100	320	460	390	3/4"	120	570	-	-	100	100	45	38
N 125/125	400	600	475	3/4"	135	700	-	-	125	125	87	48
N 150/150	400	600	458	1"	152	700	-	-	150	150	87	52
N 200/200	400	600	430	1"	180	800	-	-	200	200	100	58
N 250/250	500	700	600	1"	208	900	-	-	250	250	176	85
Q 100/80	370	370	330	260	-	-	150	310	100	80	42	34,2
Q 125/100	370	370	330	260	-	-	150	310	125	100	42	37,4
Q 150/125	450	450	400	290	-	-	185	380	150	125	77	53,9
Q 250/150	432	535	390	290	-	-	215	440	250	150	105	72,6





■ Aplicaciones:

Kit de filtración formado por filtro soplado con válvula selector + bomba de piscina, ideal para piscina privada, todo ello montado sobre una bancada común.

■ Características constructivas:

Filtro soplado de diferentes diámetros, con válvula selector en su parte superior (válvula TOP) de 4 ó 6 vías según el diámetro del filtro.

Bomba modelo OPTIMA monofásica de diferente potencia según el tipo de filtro.

Presión máxima de trabajo:..... **2 bar**
 Temperatura máxima del agua:..... **40°C**
 Velocidad máxima de filtración:..... **50 m³/h/m²**
 Diámetro del grano de arena:..... **0.5-0.8 mm**

■ Applications:

Filtration kit including a blown filter with valve, and a swimming pool pump, ideal for private pool, all mounted on a common base.

■ Constructives characteristics :

Blown filters of different sizes, with a top valve of 4 or 6 ways, depending on the filter diameter.

Swimming pool pump type OPTIMA of different power for each type of filter.

Maximum working pressure:..... **2 bar**
 Maximum water temperature:..... **40°C**
 Maximum speed filtration:..... **50 m³/h/m²**
 Sand grain diameter:..... **0.5-0.8 mm**

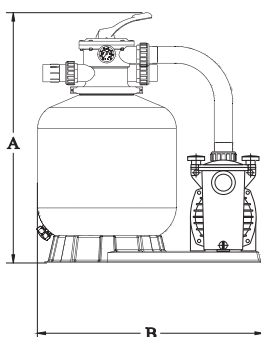

Tipo Type	Caudal Flow	Diámetro filtro Filter diameter	Válvula pulgadas Valve inches	Arena Kg Sand Kg	A	B
Kit 350 + OPTIMA 25 M	6 m ³ /h	350 mm	1,5"	20	520	600
Kit 450 + OPTIMA 33 M	8 m ³ /h	450 mm	1,5"	45	620	805
Kit 500 + OPTIMA 75 M	9 m ³ /h	500 mm	1,5"	85	640	805
Kit 650 + OPTIMA 100 M	14 m ³ /h	650 mm	1,5"	145	730	890



E

■ **Descripción:**

- Compacto y ligero.
- Diseñado básicamente para piscina domestica.
- Válvula lateral de 6 vías.
- Presión Máxima de trabajo: 2 bar / 200kPa / (29psi)
- Presión de prueba en fabrica: 3 bar / 300 kPa / (44psi)
- Temperatura máxima del agua: 40°C (104°F)
- Velocidad máxima de filtración: 50 m³/h/m²
- Diámetro del grano de arena: 0,5-0,8 mm
- Tapa transparente para fácil inspección del lecho filtrante.
- Difusor de caudal para asegurar una distribución uniforme encima del lecho filtrante.
- Purga de aire.
- El sistema de cierre con zuncho permite rotar la válvula 360°

■ **Description:**

- *Light & Compact.*
- *Designed specially for domestic pools.*
- *6 way valve.*
- *Maximum working pressure: 2 bar / 200kPa / (29psi)*
- *Pressure tested at: 3 bar / 300 kPa / (44psi)*
- *Maximum water temperature: 40°C (104°F)*
- *Maximum filtration speed: 50 m³/h/m²*
- *Diameter of sand grain: 0,5-0,8 mm*
- *Transparent lid for easy inspection of the sand bed.*
- *Flow diffuser to assure uniform distribution of the water on the sand bed.*
- *Air release valve.*
- *Flange clamp connection allows 360° rotation of the valve.*

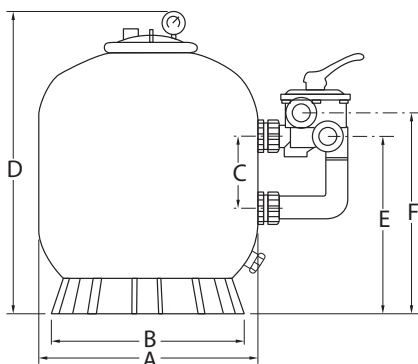

Diámetro Diameter	Filt. Area (m ²) Filt. Area (m ²)	Conexión Connection	Caudal Max. Max. Flow	Arena Sand	A	B	C	D	E	F
I-500	0,22	50 mm	10,80 m ³ /h	85 Kg	527	500	180	770	460	520
I-650	0,31	50 mm	15,30 m ³ /h	145 Kg	627	500	180	850	510	570



Filtro Bobinado



Filtro Laminado

■ Aplicaciones:

Filtros laminados ó bobinados de poliéster con válvula lateral, especialmente indicados para piscina privada y comercial, compuesto de válvula selectora de 6 posiciones (filtración, lavado, aclarado, recirculación, vaciado y cierre), manómetro y purgas de aire y agua manuales.

Máxima presión de trabajo: 2 bar
Incluyen tapa cierre de gran diámetro

■ Applications:

Laminated or bobbin polyester filters with manual side-mounted valve, indicated for private and commercial pools, including multiport 6 way valve (filtration, back-wash, rinse, recycle, drain and closed), manometer and airbled system.

Maximun working pressure: 2 bar
Lid of large diameter



Diámetro Diameter	Caudal Flow	Conexión Connection		Arena Sand	A		B		C		D	
		Lam.	Bob.		Lam.	Bob.	Lam.	Bob.	Lam.	Bob.		
400	7 m ³ /h	1 1/2"	1 1/2"	60 Kg	400 mm	400 mm	620 mm	610 mm	220 mm	220 mm	370 mm	370 mm
450	8 m ³ /h	1 1/2"	1 1/2"	75 Kg	450 mm	450 mm	660 mm	630 mm	240 mm	250 mm	390 mm	400 mm
500	9 m ³ /h	1 1/2"	1 1/2"	100 Kg	500 mm	500 mm	770 mm	710 mm	260 mm	260 mm	410 mm	410 mm
600	14 m ³ /h	1 1/2"	1 1/2"	130 Kg	600 mm	600 mm	840 mm	830 mm	330 mm	340 mm	480 mm	480 mm
750	21 m ³ /h	2"	2"	250 Kg	750 mm	750 mm	980 mm	950 mm	365 mm	385 mm	500 mm	615 mm
900	30 m ³ /h	2"	2"	510 Kg	900 mm	900 mm	1.100 mm	1.040 mm	500 mm	520 mm	750 mm	750 mm
1.050	43 m ³ /h	-	2"	575 Kg	-	1.050 mm	-	1.320 mm	-	600 mm	-	780 mm

Filtros para Piscinas Públicas

Serie "Filtros para Piscinas Públicas"



E

Aplicaciones:

Filtros de poliéster bobinados con fibra de vidrio, con boca de hombre superior, lecho filtrante de 1 metro de silex, brazos colectores en parrilla, válvula de purga de aire, desagüe para silex y agua. Incluye manómetro de presión de filtro, Entrada y salida con brida loca.

Presión máxima de trabajo: 2,5 bar.
La batería de válvulas se suministra aparte.

Applications:

Polyester and fiberglass bobbin wound filters, with man hole on the top, 1 meter filtration bed, arm collectors air bleed valve and water drain. Filter pressure gauge. Inlet and outlet connections with lose flanges.

Maximum working pressure: 2,5 bar
The battery valves are supplied separately.

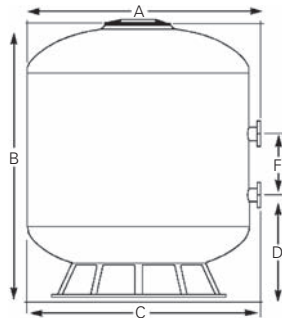

Diámetro Diameter	A	B	C	D	E
1.050	1050	1320	1130	610	400
1.200	1200	1560	1280	655	400
1.400	1400	1810	1480	700	450
1.600	1600	2030	1680	768	450
1.800	1800	2050	1880	840	450
	1800	2050	1880	830	450
2.000	2000	2300	2080	870	450
	2000	2300	2080	870	500

Diámetro Diameter	Velocidad de filtración / Filtration Rate								Arena Sand	Salidas Output
	20 m³		30 m³		40 m³		50 m³			
	Caudal Flow	Conexión	Caudal Flow	Conexión	Caudal Flow	Conexión	Caudal Flow	Conexión		
1.050	17 m³/h	DN 63	25 m³/h	DN 75	34 m³/h	DN 75	43 m³/h	DN 90	1.100 Kg	ø 63/75/90
1.200	22 m³/h	DN 75	33 m³/h	DN 75	45 m³/h	DN 90	56 m³/h	DN 90	1.400 Kg	ø 75/90
1.400	30 m³/h	DN 75	46 m³/h	DN 90	61 m³/h	DN 110	77 m³/h	DN 110	1.900 Kg	ø 75/90/110
1.600	40 m³/h	DN 90	60 m³/h	DN 110	80 m³/h	DN 110	100 m³/h	DN 125	2.600 Kg	ø 90/110/125
1.800	50 m³/h	DN 90	76 m³/h	DN 110	101 m³/h	DN 125	125 m³/h	DN 140	3.500 Kg	ø 90/110/125
										ø 140/160
2.000	62 m³/h	DN 110	94 m³/h	DN 125	125 m³/h	DN 140	157 m³/h	DN 160	4.500 Kg	ø 110/125/140
										ø 140/160



■ Bomba de pequeñas dimensiones.
Caudal constante regulable manualmente.
Esta bomba es de diafragma activado por solenoide.
El diafragma es la única pieza móvil.
Incorpora válvulas de Vitón.

■ Líquidos:

Ácido Clorhídrico
Sosa Cáustica
Ácido Sulfúrico
Hipoclorito Sódico
Bisulfito Sódico
Y otros ácidos y productos alcalinos

El potenciómetro de regulación de caudal está marcado con doble escala seleccionable por conmutador.

La escala azul para regulación de 0 a 100%. La escala roja es de más precisión para regulación de de 0 a 20%.

Equipadas con tubos y accesorios para conexiones de aspiración e impulsión.

■ A small pump.
Constant flow regulable by hand.
This pump has a solenoid operated diaphragm, which is the only moving part.
Viton valves .

■ Liquids:

Hydrochloric acid
Caustic soda
Sulphuric acid
Sodium Hypochlorite
Sodium bisulphite
And other acid and alkaline products

The flow regulation potentiometer is marked with a double scale that can be selected by a switch.

The blue scale for regulation from 0 to 100%. The red scale is for more precision for regulation from 0 to 22%.

Fitted with pipes and accessories for suction and drive connections.

Tipo Type	Pot. Abs. Watt	Volt.	A	Caudal máx. Max. Flow lts./h.	Presion máx. Max. Pressure bar	N.º Impulsos x min.	Alt. Asp. Suction Height
PL 23	40	II 230	0,18	5	7	100	2
PL 50	75	II 230	1,1	10	5	110	2
PL 75	140	II 230	2	20	5	160	2

Serie "DIVER-SUB"	76
Serie "Kit FC + DRP"	77
Serie "AR"	78
Serie "SP"	81
Serie Radiales "S18-S25-S36-S48-S66"	85
Serie Semi-Axiales 6"-8"-10"	88
Tuberia Flexible "RYLBRUN" para bombas sumergidas	93
Serie "FRANKLIN"	94
Serie "SACI"	95

■ Aplicaciones:

SERIE SUB S: Bomba sumergible doméstica para pozos de 4" mínimo. Incorpora un nuevo sistema antibloqueo de **turbina flotante**.

■ INMERSION MAXIMA 15 mts.

SERIE DIVER: Bomba sumergible doméstica para pozos de 6" mínimo, para trasiego de agua limpia con un contenido máximo de 60 gr./m³ de arena. La refrigeración del motor se efectúa por la misma agua bombeada, lo que permite un servicio continuo con un nivel mínimo de agua de 100 mm.

■ Características constructivas

SERIE SUB S: Camisa exterior, camisa interna motor y eje en acero inoxidable. Turbinas en resina acetática y difusores en policarbonato con inserto de cerámica antidesgaste. Condensador incorporado. Equipada con 20 mts. de cable H07RNF y con 20 mts. de cuerda de nylon. **Incorpora válvula de retención en la impulsión.**

SERIE DIVER: Camisa exterior, asa, camisa interna motor, en acero inoxidable AISI 304. **Eje en AISI 316.** Soporte interiores motor en latón estampado. Turbinas y difusores en Noryl con anillos de roce en acero inoxidable. Sello mecánico en carburo de silicio. Equipada con 10 metros de cable.

*Se recomienda la instalación de una válvula de retención en la impulsión.

■ Motor:

Estator hermético encamisado. Totalmente en acero inoxidable AISI 304. Permite un máximo de 40 arrancadas hora.



SUB S



DIVER



DIVER HF

■ Applications:

Sub-S series: Domestic submersible pump for 4" wells at least. Equipped with a Floating Impeller.

■ Maximum immersion 15 mts.

Diver series: A domestic, submersible pump for 6" wells at least, for the transfer of clean water with a maximum sand content of 60 g/m³.

The motor is cooled by the pumped water itself, which allows continuous service with a minimum water level of 100 mm.

■ Construction:

Sub-S series: Exterior cladding, internal motor cladding and shaft in stainless steel AISI 304.

Impeller in acetatic resins. Difusors in polycarbonate with a ceramic insert.

Fitted with 20 mts. of electric cable, and 20 mts. of nylon cable. **Equipped with a retention valve.**

Diver series: Exterior cladding, internal motor cladding in stainless steel AISI 304. and shaft in stainless steel AISI 316. impellers and difusors in Noryl with mechanical seal in silicium carbide. equipped with 10 mts of cable.

* It is recommended to install a retention valve in the drive .

■ Motor:

Cladded hermetic stator. Entirely in AISI 304 stainless steel.

Allows a maximum of 40 starts per hour .

Tipo Type	Cond. µF	Potencia		"A"		Caudal m ³ /h / Flow m ³ /h									
		HP	KW	II 230 V		0	0,6	1,2	1,8	2,4	3	3,6	4,2	4,8	5,6
				Altura m.c.a. / Height w.c.m.											
SUB S-6	16	1,1	0,8	3,8		50	48	39	28	12	2				
SUB S-8	16	1,5	1,1	5		57	53	50	48	43	40	35	27	19	9

Ø Impulsión SUB S: 1 1/4" - Outlet Ø SUB S: 1 1/4"

Tipo Type	Con. µF	Potencia		"A"		Caudal m ³ /h / Flow m ³ /h											
		HP	KW	II 230		III 400		0,3	1,5	2,7	4,5	5,1	6	7,5	9	10,5	12
				Altura m.c.a. / Height w.c.m.													
DIVER 100 M	20	1	0,75	5,7	-	50	40	33	19	12	3						
DIVER 100 T	-	1	0,75	-	2,3												
DIVER 150 M	30	1,5	1,1	8,1	-	70	58	45	24	17	6						
DIVER 150 T	-	1,5	1,1	-	3,1												
DIVER HF 151 M	30	1,5	1,1	8,1	-	41	40	38	35	33	32	28	24	20	15		
DIVER HF 151 T	-	1,5	1,1	-	3,5												
DIVER HF 200 M	35	2	1,5	10,8	-	56	55	51	48	46	44	39	34	28	20		
DIVER HF 200 T	-	2	1,5	-	4,9												

Ø Impulsión: 1 1/4" - Outlet Ø: 1 1/4"



F

■ **Aplicaciones:**

Las bombas que conforman los KIT FC + DRP puede trabajar como equipos de presión si se le instalan con un presostato y un calderín, o bien a través de un Presscontrol. **Las bombas disponen de protección contra la marcha en seco gracias al sistema electrónico DRP.** El motor no necesita cuadro de control y la bomba viene equipada con 20 metros de cable, enchufe y 20 metros de cuerda lista para instalar en el pozo. Gracias a su alta capacidad de refrigeración, puede trabajar vertical u horizontalmente sin necesidad de entubar.

■ **Características constructivas:**

Soporte, cuerpo superior, cubrecable, turbinas y difusores en tecnopolímero de alta resistencia. Camisa en acero inoxidable. Acoplamiento estándar NEMA.

Temperatura máxima del líquido: + 40° C.

Máximo contenido en arena: 120g/m³.

Conjunto de turbinas y difusores compuestos de cojinete y anillo flotante en vinilo, que la hacen muy resistente a la arena y a abrasivos equivalentes.

■ **Motor:**

Motor refrigerado por aceite con condensador interno de alta calidad, que garantiza hasta 150 arranques/hora. El motor dispone de condensador interno y protección eléctrica integrada. Motor en acero inoxidable AISI-304.

■ **Applications:**

The KIT FC + DRP pumps can work as pressure units when you install a pressure switch and an air vessel, or through a Presscontrol. **The pumps have protection against dry running due to electronic DRP.** The motor don't requires control box and the pump is equipped with 20 meters of cable, plug connector and 20 meters of rope ready to install in the well. Thanks to it's high cooling capacity, it can work vertically or horizontally without the need to intubate.

■ **Construction:**

Support, upper body, cable cover, impellers and diffusers in high polymer resistance technology. Stainless steel sleeve. NEMA standard coupling.

Maximum liquid temperature: +40 ° C

Maximum sand content: 20g/m³

Set of diffusers and impellers are compounds of bearing and floating ring vinyl, which makes it highly resistant to sand and abrasive equivalent.

■ **Motor:**

Oil cooled engine with high quality internal capacitor, which guarantees up to 150 starts/hour. The motor has internal capacitor and electrical protection. AISI-304 tainless steel motor.

Tipo Type	Potencia		"A"	Caudal m ³ /h / Flow m ³ /h						Diámetro Diameter
	HP	KW		II 230 V	0	1,8	2,4	4,2	4,8	
			Altura m.c.a. / Height w.c.m.							
KIT FC 100 M + bomba 5-8.20 DRP	1	0,75	5,7	49	46	44	37	33	24	1 1/4"
KIT FC 150 M + bomba 5-13.20 DRP	1,5	1,1	8,6	80	75	72	60	54	39	1 1/4"

■ Aplicaciones:

Bombas sumergibles de 4" multiturbinas de elevado rendimiento hidráulico especialmente indicadas para la elevación, distribución y presurización en instalaciones hidráulicas civiles e industriales. Montaje en equipos de presión, cisternas, sistemas de riego, de lavado, etc....

■ Características Constructivas:

Soporte y cuerpo superior (con válvula de retención incorporada) en Acero inoxidable AISI 304 de fundición. Incorporan un nuevo sistema antibloqueo «Turbina flotante» generan una «resistencia absoluta al desgaste» y máxima robustez y fiabilidad en el tiempo. Turbinas en noril y difusores en policarbonato en acero inoxidable AISI 304. Camisa exterior en acero inoxidable AISI 304. Manguito guía superior interno en caucho. Rejilla, cubre cable y válvula de retención en acero inoxidable AISI 304.

■ Motor:

Podemos escoger entre dos tipos de motor:

Motor FRANKLIN que cumple con la normativa DIN e ISO y cuyas características principales son: Estator hermético en acero inoxidable, acoplamiento internacional tipo NEMA, no necesita mantenimiento y están lubricados por agua.

Motor FC que cumple con la normativa DIN e ISO y cuyas características principales son: Estator de acero inoxidable en baño de aceite atóxico, acoplamiento internacional tipo NEMA, no necesita mantenimiento.

Temperatura máxima del agua: + 40° C



■ Applications:

4" submersible pumps with multiple impellers with a high hydraulic performance, especially recommended for elevation, distribution and pressurisation in civil and industrial hydraulic installations. Assembly in pressure units, cisterns, irrigation, washing systems, etc.

■ Construction:

Support and upper body (with built-in retention valve) in cast AISI 304 stainless steel. They incorporate a new "Floating Impeller" That generate and "absolute resistance to wear" and maximum solidity and reliability with time. Impellers and diffusers in Technopolymer "A". Exterior cladding in AISI 304 stainless steel.

■ Motor:

We can choose between two types of motors:

FRANKLIN motor complying with DIN and ISO standards with the following main features: Hermetic stator in stainless steel, international NEMA coupling, no need for maintenance, water lubricated.

FC motor complying with DIN and ISO standards with the following main features: Stator in stainless steel, international NEMA coupling, no need for maintenance, atoxic oil lubricated.

Maximum water temperature: + 40° C.

Tipo Type	Voltage Voltage	Cond. µF	Potencia		"A"	Caudal m ³ /h / Flow m ³ /h							Longitud Lenght	
			HP	KW		0	0,6	0,9	1,2	1,5	2,1	2,4		
						Altura m.c.a. / Height w.c.m.								
AR 15-19 M	II 230	20			4,3									752
AR 15-19 T	III 230	-	0,75	0,55	2,8	126	105	86	60	30				723
AR 15-19 T	III 400	-			1,6									723
AR 15-26 M	II 230	35			5,7									941
AR 15-26 T	III 230	-	1	0,75	3,7	173	141	117	81	39				913
AR 15-26 T	III 400	-			2,1									913
AR 15-38 M	II 230	40			8,6									1191
AR 15-38 T	III 230	-	1,5	1,1	5,2	253	208	169	117	52				1163
AR 15-38 T	III 400	-			3,0									1163
AR 20-15 M	II 230	20			4,3									691
AR 20-15 T	III 230	-	0,75	0,55	2,8	95	85	79	72	64	41	38		662
AR 20-15 T	III 400	-			1,6									662
AR 20-20 M	II 230	35			5,7									809
AR 20-20 T	III 230	-	1	0,75	3,7	127	115	107	95	83	56	40		781
AR 20-20 T	III 400	-			2,1									781
AR 20-30 M	II 230	40			8,6									1057
AR 20-30 T	III 230	-	1,5	1,1	5,2	195	183	170	155	137	92	69		1029
AR 20-30 T	III 400	-			3									1029
AR 20-36 M	II 230	50			10,6									1186
AR 20-36 T	III 230	-	2	1,5	6,9	234	218	202	185	153	110	80		1157
AR 20-36 T	III 400	-			4									1157

Tipo Type	Voltaje Voltage	Cond. µF	Potencia		"A"	Caudal m³/h / Flow m³/h										Longitud Lenght	
			HP	KW		0	1,5	2,4	2,7	3,0	3,6	4,2	4,8	5,4	6		
						Altura m.c.a. / Height w.c.m.											
AR 30-10 M	II 230	20	0,75	0,55	4,3	69	60	44	37	29							595
AR 30-10 T	III 230	-			2,8												566
AR 30-10 T	III 400	-			1,6												566
AR 30-14 M	II 230	35	1	0,75	5,7	92	79	60	52	42							693
AR 30-14 T	III 230	-			3,7												665
AR 30-14 T	III 400	-			2,1												665
AR 30-20 M	II 230	40	1,5	1,1	8,6	139	120	90	75	60							826
AR 30-20 T	III 230	-			5,2												798
AR 30-20 T	III 400	-			3,0												798
AR 40-21 M	II 230	50	2	1,5	10,6	142	132	115	108	100	79	49					875
AR 40-21 T	III 230	-			6,9												846
AR 40-21 T	III 400	-			4,0												846
AR 60-07 M	II 230	20	0,75	0,55	4,3	46	43	40	39	37	33	28	21	13	7		572
AR 60-07 T	III 230	-			2,8												543
AR 60-07 T	III 400	-			1,6												543
AR 60-09 M	II 230	35	1	0,75	5,7	59	55	51	49	47	43	37	28	20	10		643
AR 60-09 T	III 230	-			3,7												615
AR 60-09 T	III 400	-			2,1												615
AR 60-14 M	II 230	40	1,5	1,1	8,6	93	87	81	79	76	68	58	47	33	20		779
AR 60-14 T	III 230	-			5,2												751
AR 60-14 T	III 400	-			3,0												751
AR 60-18 M	II 230	50	2	1,5	10,6	120	113	105	102	98	88	75	60	42	25		894
AR 60-18 T	III 230	-			6,9												865
AR 60-18 T	III 400	-			4,0												865
AR 60-27 T	III 230	-	3	2,2	10,2	175	164	152	147	141	127	109	87	61	35		1123
AR 60-27 T	III 400	-			5,9												1123
AR 60-35 T	III 230	-			13,5												1441
AR 60-35 T	III 400	-	7,8	1441													
AR 60-48 T	III 230	-	5,5	4	17,3	322	299	276	267	256	231	199	160	118	70		1836
AR 60-48 T	III 400	-			10,0												1836

Ø Impulsión: 1 1/4" - Outlet Ø: 1 1/4"

Tipo Type	Voltaje Voltage	Cond. µF	Potencia		"A"	Caudal m³/h / Flow m³/h									Longitud Lenght		
			HP	KW		0	3,0	3,6	4,2	4,8	5,4	6	7,2	8,4		9,6	
						Altura m.c.a. / Height w.c.m.											
AR 110-07 M	II 230	35	1	0,75	5,7	42	36	34	32	30	28	25	19	11			689
AR 110-07 T	III 230	-			3,7												661
AR 110-07 T	III 400	-			2,1												661
AR 110-10 M	II 230	40	1,5	1,1	8,6	62	53	51	48	45	41	38	29	18			810
AR 110-10 T	III 230	-			5,2												782
AR 110-10 T	III 400	-			3,0												782
AR 110-14 M	II 230	50	2	1,5	10,6	90	77	74	71	68	63	59	46	28			963
AR 110-14 T	III 230	-			6,9												934
AR 110-14 T	III 400	-			4,0												934
AR 110-20 T	III 230	-	3	2,2	10,2	125	107	102	97	92	86	80	62	40			1187
AR 110-20 T	III 400	-			5,9												1187
AR 110-27 T	III 230	-			13,5												1555
AR 110-27 T	III 400	-	7,8	1555													
AR 110-36 T	III 230	-	5,5	4	17,3	221	190	181	173	164	154	143	112	72			1901
AR 110-36 T	III 400	-			10,0												1901

Ø Impulsión: 2" - Outlet Ø: 2"



Tipo Type	Voltaje Voltage	Cond. µF	Potencia		"A"	Caudal m³/h / Flow m³/h										Longitud Lenght
			HP	KW		0	4,8	5,4	6	7,2	8,4	9,6	10,8	12		
						Altura m.c.a. / Height w.c.m.										
AR 140-06 M	II 230	40	1,5	1,1	8,6	39	36	35	34	32	29	26	22	17	683	
AR 140-06T	III 230	-			5,2										655	
AR 140-06T	III 400	-			3,0										655	
AR 140-08 M	II 230	50	2	1,5	10,6	52	48	47	46	43	39	35	29	24	774	
AR 140-08T	III 230	-			6,9										745	
AR 140-08T	III 400	-			4,0										745	
AR 140-13T	III 230	-	3	2,2	10,2	82	75	73	71	66	59	50	40	30	929	
AR 140-13T	III 400	-			5,9										929	
AR 140-17T	III 230	-			13,5										1204	
AR 140-17T	III 400	-	7,8	1204												
AR 140-23T	III 230	-	5,5	4	17,3	148	134	131	127	118	108	95	79	60	1504	
AR 140-23T	III 400	-			10,0										1504	
AR 140-32T	III 230	-			23,7										1936	
AR 140-32T	III 400	-	13,7	1936												

Ø Impulsión: 2" - Outlet Ø: 2"

Tipo Type	Voltaje Voltage	Cond. µF	Potencia		"A"	Caudal m³/h / Flow m³/h										Longitud Lenght
			HP	KW		0	6	7,2	8,4	9,6	10,8	12	13,2	14,4	15,6	
						Altura m.c.a. / Height w.c.m.										
AR 200-07 M	II 230	50	2	1,5	10,6	45	37	36	33	31	28	25	22	18	14	890
AR 200-07T	III 230	-			6,9											861
AR 200-07T	III 400	-			4											861
AR 200-10T	III 230	-	3	2,2	10,2	64	54	52	48	44	41	36	32	26	20	1046
AR 200-10T	III 400	-			5,9											1046
AR 200-14T	III 230	-			13,5											1496
AR 200-14T	III 400	-	7,8	1496												
AR 200-19T	III 230	-	5,5	4	17,3	120	102	97	91	89	76	68	58	48	37	1778
AR 200-19T	III 400	-			10											1778
AR 200-26T	III 230	-			23,7											2257
AR 200-26T	III 400	-	13,7	2257												

Ø Impulsión: 2" - Outlet Ø: 2"

Tipo Type	Voltaje Voltage	Cond. µF	Potencia		"A"	Caudal m³/h / Flow m³/h										Longitud Lenght
			HP	KW		0	5,4	7,2	8,4	9,6	10,8	12	14	18	24	
						Altura m.c.a. / Height w.c.m.										
AR 250-08T	III 230	-	3	2,2	10,2	51			41	39	37	35	32	24	12	1032
AR 250-08T	III 400	-			5,9											1032
AR 250-11T	III 230	-			13,5											1387
AR 250-11T	III 400	-	7,8	1387												
AR 250-15T	III 230	-	5,5	4	17,3	97			79	76	73	69	64	50	27	1732
AR 250-15T	III 400	-			10,0											1732
AR 250-20T	III 230	-			23,7											2187
AR 250-20T	III 400	-	13,7	2187												

Ø Impulsión: 2" - Outlet Ø: 2"



■ **Aplicaciones:**

Bombas sumergibles de 4" multiturbinas de elevado rendimiento hidráulico, especialmente indicadas para la elevación, distribución y presurización en instalaciones hidráulicas civiles e industriales. Montaje en equipos de presión, cisternas, sistemas de riego, de lavado, etc....

■ **Características Constructivas:**

Bombas sumergibles con turbinas, difusores, camisa, cuerpo aspiración, cuerpo impulsión, cubrecables, rejilla de aspiración y tornillos en acero inoxidable **AISI-304**.

Válvula de retención de acero inoxidable incorporada.

Casquillos guías en goma especial resistentes a la abrasión.

Turbinas equilibradas estáticamente y dinámicamente.

Máximo contenido en arena 50 gr/m³.

Límite de temp. del líquido:

+15° C a + 40° C.

■ **Motor:**

Podemos escoger entre dos tipos de motor:

Motor FRANKLIN que cumple con la normativa DIN e ISO y cuyas características principales son: Estator hermético en acero inoxidable, acoplamiento internacional tipo NEMA, no necesita mantenimiento y están lubricados por agua.

Motor FC que cumple con la normativa DIN e ISO y cuyas características principales son: Estator en acero inoxidable en baño de aceite atóxico, acoplamiento internacional tipo NEMA, no necesita mantenimiento.

Temperatura máxima del agua: + 40° C

■ **Applications:**

4" submersible pumps with multiple impellers with a high hydraulic yield, especially recommended for elevation, distribution and pressurisation in civil and industrial hydraulic installations. Assembly in pressure units, cisterns, irrigation, washing systems, etc.

■ **Construction:**

Impellers, difusors, inlet and outlet body, completely manufactured in stainless steel AISI-304. Guide ring in rubber resistant against abrasion. Static and dynamic balanced impellers. Maximum content of sand in water 50 gr./ m³.

■ **Motor:**

We can choose between two types of motors:

FRANKLIN motor complying with DIN and ISO standards with the following main features: Hermetic stator in stainless steel, international NEMA coupling, no need for maintenance, water lubricated.

FC motor complying with DIN and ISO standards with the following main features: Stator in stainless steel, international NEMA coupling, no need for maintenance, atoxic oil lubricated.

Maximum water temperature: + 40° C.

F



Tipo Type	Voltaje Voltage	Cond. µF	Potencia		"A"	Caudal m ³ /h / Flow m ³ /h							Longitud Lenght
			HP	KW		0	0,9	1,2	1,5	1,8	2,1	2,4	
						Altura m.c.a. / Height w.c.m.							
SP 10-13 M	II 230	20	0,75	0,55	4,3	77	71	68	61	56	48	38	711
SP 10-13 T	III 230	-			2,8								682
SP 10-13 T	III 400	-			1,6								682
SP 10-18 M	II 230	35	1	0,75	5,7	106	98	92	84	77	66	51	843
SP 10-18 T	III 230	-			3,7								816
SP 10-18 T	III 400	-			2,1								816
SP 10-23 M	II 230	40	1,5	1,1	8,6	136	124	118	108	98	84	67	977
SP 10-23 T	III 230	-			5,2								949
SP 10-23 T	III 400	-			3,0								949
SP 10-33 M	II 230	50	2	1,5	10,6	195	181	171	157	141	120	97	1239
SP 10-33 T	III 230	-			6,9								1210
SP 10-33 T	III 400	-			4,0								1210
SP 10-48 T	III 230	-	3	2,2	10,2	282	258	241	221	199	171	137	1554
SP 10-48 T	III 400	-			5,9								1554

Ø Impulsión: 1 1/4" - Outlet Ø: 1 1/4"

Sumergibles 4" en Acero Inoxidable AISI-304

Serie "SP"



Tipo Type	Voltaje Voltage	Cond. µF	Potencia		"A"	Caudal m³/h / Flow m³/h										Longitud Lenght									
			HP	KW		0	0,9	1,2	1,5	1,8	2,1	2,4	3	3,6	4,2										
						Altura m.c.a. / Height w.c.m.																			
SP 18-9 M	II 230	20	0,75	0,55	4,3	58												627							
SP 18-9T	III 230	-			2,8													54	52	49	48	43	36	25	598
SP 18-9T	III 400	-	1	0,75	1,6	78												598							
SP 18-12 M	II 230	35			5,7													67	65	62	59	52	42	28	717
SP 18-12T	III 230	-			3,7																				690
SP 18-12T	III 400	-	2,1	1,5	1,1	117												690							
SP 18-18 M	II 230	40	8,6															101	98	93	89	78	64	42	872
SP 18-18T	III 230	-	5,2																						844
SP 18-18T	III 400	-	3,0															844							
SP 18-25 M	II 230	50	2	1,5	10,6	162												1048							
SP 18-25T	III 230	-			6,9													140	134	128	121	106	86	58	1019
SP 18-25T	III 400	-			4,0													1019							
SP 18-33T	III 230	-	3	2,2	10,2	212												1239							
SP 18-33T	III 400	-			5,9													1239							
SP 18-45T	III 230	-	4	3	13,5	292												1642							
SP 18-45T	III 400	-			7,8													1642							

Ø Impulsión: 1 1/4" - Outlet Ø: 1 1/4"



Tipo Type	Voltaje Voltage	Cond. µF	Potencia		"A"	Caudal m³/h / Flow m³/h										Longitud Lenght
			HP	KW		0	1,8	2,1	2,4	3	3,6	4,2	4,8	5,4	6	
						Altura m.c.a. / Height w.c.m.										
SP 25-6 M	II 230	20	0,75	0,55	4,3	38	34	33	32	30	28	26	24	21	17	564
SP 25-6T	III 230	-			2,8											535
SP 25-6T	III 400	-	1,6	535												
SP 25-8 M	II 230	35	1	0,75	5,7	57	44	43	42	40	38	35	32	28	22	633
SP 25-8T	III 230	-			3,7											606
SP 25-8T	III 400	-			2,1											606
SP 25-12 M	II 230	40	1,5	1,1	8,6	75	68	66	65	63	58	53	49	42	36	746
SP 25-12T	III 230	-			5,2											718
SP 25-12T	III 400	-			3,0											718
SP 25-17 M	II 230	50	2	1,5	10,6	106	95	92	90	85	79	73	67	58	50	880
SP 25-17T	III 230	-			6,9											851
SP 25-17T	III 400	-			4,0											851
SP 25-21T	III 230	-	3	2,2	10,2	131	117	114	110	103	98	90	82	72	62	964
SP 25-21T	III 400	-			5,9											964
SP 25-25T	III 230	-	3	2,2	10,2	156	140	136	131	127	118	110	100	90	74	1048
SP 25-25T	III 400	-			5,9											1048
SP 25-33T	III 230	-	4	3	13,5	206	182	178	173	165	155	142	130	115	98	1375
SP 25-33T	III 400	-			7,8											1375
SP 25-44T	III 230	-	5,5	4	17,3	275	244	239	232	221	208	191	174	155	130	1682
SP 25-44T	III 400	-			10,0											1682

Ø Impulsión: 1 1/2" - Outlet Ø: 1 1/2"

Tipo Type	Voltaje Voltage	Cond. µF	Potencia		"A"	Caudal m ³ /h / Flow m ³ /h										Longitud Lenght
			HP	KW		2,4	3	3,6	4,2	4,8	5,4	6	8,4	9,6	11	
						Altura m.c.a. / Height w.c.m.										
SP 40-07 M	II 230	40	1,5	1,1	8,6	36	34	34	33	33	32	32	25	20	15	823
SP 40-07T	III 230	-			5,2											795
SP 40-07T	III 400	-			3,0											795
SP 40-10 M	II 230	50	2	1,5	10,6	52	51	51	50	50	49	49	40	34	27	977
SP 40-10T	III 230	-			6,9											949
SP 40-10T	III 400	-			4,0											949
SP 40-15T	III 230	-	3	2,2	10,2	79	77	76	75	73	72	70	60	50	40	1188
SP 40-15T	III 400	-			5,9											1188
SP 40-18T	III 230	-	4	3	13,5	91	89	88	87	85	83	81	70	60	48	1465
SP 40-18T	III 400	-			7,8											1465
SP 40-25T	III 230	-	5,5	4	17,3	131	128	126	122	119	116	113	97	81	61	1835
SP 40-25T	III 400	-			10,0											1835

Ø Impulsión: 2" - Outlet Ø: 2"

Tipo Type	Voltaje Voltage	Cond. µF	Potencia		"A"	Caudal m ³ /h / Flow m ³ /h										Longitud Lenght
			HP	KW		6	7,2	8,4	9,6	11	12	13	14	15	18	
						Altura m.c.a. / Height w.c.m.										
SP 70-07T	III 230	-	3	2,2	10,2	40	39	37	36	35	32	30	28	26	18	991
SP 70-07T	III 400	-			5,9											991
SP 70-10T	III 230	-	4	3	13,5	58	56	54	52	50	46	43	40	38	26	1337
SP 70-10T	III 400	-			7,8											1337
SP 70-13T	III 230	-	5,5	4	17,3	75	72	70	67	65	60	57	53	49	34	1608
SP 70-13T	III 400	-			10,0											1608
SP 70-18T	III 230	-	7,5	5,5	23,7	104	100	97	93	90	83	78	73	68	46	2048
SP 70-18T	III 400	-			13,7											2048
SP 70-25T	III 230	-	10	7,5	-	145	140	135	130	125	115	109	102	95	65	2579
SP 70-25T	III 400	-			18,4											2579

Ø Impulsión: 2" - Outlet Ø: 2"

Sumergibles 6" Radiales Serie "S18-S25-S36-S48-S66"



■ Aplicaciones:

Bombas sumergibles para pozos de 6" mínimo, muy adecuadas para aplicaciones civiles o industriales, en riegos por aspersión, comunidades, urbanizaciones, etc...

■ Características constructivas:

Bombas sumergibles con rodetes radiales y semiaxiales, difusores en Noryl. Cada elemento incorpora anillos de roce y cuerpo difusor en acero inoxidable. Eje, camisa, manguito, cubrecable, rejilla aspiración aros y tornillos son en acero inoxidable. Cuerpo de aspiración e impulsión en latón. Válvula de retención incorporada. Las curvas de funcionamiento son acordes con las normas ISO 2548 clase C. Máxima cantidad de arena: 40 g/m³
Límite temp. del líquido: +15° C a + 40° C

■ Motor:

Bombas equipadas de serie con motor **FRANKLIN** que cumple con la normativa DIN e ISO y cuyas características principales son: Estator hermético en acero inoxidable, acoplamiento internacional tipo NEMA, no necesita mantenimiento y están lubricados por agua, con lo cual en caso de pérdida de líquido no hay peligro de contaminación del agua. Para potencias de hasta 7,5 CV el motor es de 4" para arranque estrella-triángulo. A partir de 7,5 CV los motores son de 6" y en todos los casos debe especificarse el voltaje requerido.

■ Applications:

Submersible pumps for 6" wells minimum, highly suitable for civil and industrial installations, in aspersion irrigation, communities, housing estates, etc.

■ Construction:

Submersible pumps with radial and semi-axial impellers, diffusers in Noryl. Each element includes contact rings and diffuser body in stainless steel. Shaft, cladding, sleeve, cable cover, suction grille, rings and bolts in stainless steel. Suction and drive body. Built-in brass retention valve. The working curves comply with standard ISO 2548 class C.

Maximum amount of sand: 40 g/m³

Temp. limit of the liquid: + 15° C to + 40° C.

■ Motor:

Pumps fitted as standard with a **FRANKLIN** motor complying with DIN and ISO standards with the following main features: Hermetic stator in stainless steel, international NEMA coupling, no need for maintenance, water lubricated therefore preventing the chance of contamination in the event of loss of liquid. For powers of up to 7.5 HP, the motor is 4" for star-triangle starting. From 7.5 HP, the motors are 6" and, in all cases, must adapt to the required voltage.

Tipo Type	Potencia		"A"		Caudal m ³ /h / Flow m ³ /h								Ø Motor	Longitud Lenght	
	HP	KW	III 230	III 400	0	7,2	8,4	9,6	10,6	12	13,2	15			18
					Altura m.c.a. / Height w.c.m.										
S 18 - 6	5,5	4	16,4	9,5	90	85	83	79	76	72	69	62	44	4" dir	1233
S 18 - 10	7,5	5,5	22,1	12,8	134	128	125	120	115	109	103	93	66	4" dir 6" ET	1503
S 18 - 13	10	7,5	28,2	16,3	179	171	167	160	153	146	136	124	88	6"	1566
S 18 - 16	12,5	9,3	36,4	21	224	214	208	200	193	183	172	155	110	6"	1709
S 18 - 19	15	11	41,5	24	269	255	249	241	231	219	207	166	133	6"	1856
S 18 - 24	20	15	55	32	359	343	333	321	308	292	275	258	177	6"	2111
S 18 - 30	25	18,5	69,2	40	449	429	416	402	385	365	344	311	221	6"	2457

Ø impulsión: 2 1/2" - Outlet Ø : 2 1/2"

Tipo Type	Potencia		"A"		Caudal m ³ /h / Flow m ³ /h								Ø Motor	Longitud Lenght
	HP	KW	III 230	III 400	0	6	12	15	18	21	24	25,5		
					Altura m.c.a. / Height w.c.m.									
S 25 - 8	5,5	4	16,4	9,5	86	77	68	66	58	48	36	28	4" dir	1318
S 25 - 12	7,5	5,5	22,1	12,8	124	110	96	93	79	63	45	35	4" dir 6" ET	1588
S 25 - 15	10	7,5	28,2	16,3	159	141	124	122	106	84	63	49	6"	1656
S 25 - 18	12,5	9,3	36,4	21	187	167	146	144	128	104	76	60	6"	1804
S 25 - 23	15	11	41,5	24	236	206	185	181	158	129	93	73	6"	2031
S 25 - 30	20	15	55	32	300	269	241	234	207	165	118	92	6"	2321
S 25 - 38	25	18,5	69,2	40	387	342	303	294	256	205	148	117	6"	2457

Ø impulsión: 2 1/2" - Outlet Ø : 2 1/2"

Tipo Type	Potencia		"A"		Caudal m ³ /h / Flow m ³ /h								Ø Motor	Longitud Lenght
	HP	KW	III 230	III 400	0	6	12	15	18	24	30	36		
					Altura m.c.a. / Height w.c.m.									
S 36 - 4	5,5	4	15,9	9	58	54	50	48	46	38	27	16	4" dir	1233
S 36 - 6	7,5	5,5	22,1	12,8	87	80	76	70	68	56	42	24	4" dir 6" ET	1463
S 36 - 8	10	7,5	28,2	16,3	117	105	101	95	91	75	55	32	6"	1526
S 36 - 10	12,5	9,3	36,4	21	146	135	127	118	114	95	70	40	6"	1669
S 36 - 12	15	11	41,5	24	174	162	152	142	137	114	84	48	6"	1816
S 36 - 14	20	15	55	32	204	190	178	166	160	133	98	56	6"	1996
S 36 - 16	20	15	55	32	233	221	203	191	182	151	112	64	6"	2111
S 36 - 20	25	18,5	69,2	40	292	278	254	235	228	190	140	80	6"	2457
S 36 - 24	30	22	81,2	47	350	336	305	290	274	228	168	97	6"	2747

Ø impulsión: 2 1/2" - Outlet Ø : 2 1/2"

Sumergibles 6" Radiales

Serie "S48-S66"

Tipo Type	Potencia		"A"		Caudal m ³ /h / Flow m ³ /h								Ø Motor	Longitud Lenght	
	HP	KW	III 230	III 400	0	6	12	18	24	30	36	42			48
					Altura m.c.a. / Height w.c.m.										
S 48 - 3	5,5	4	16,4	9,5	46	44	43	42	39	36	30	23	13	4" dir	1183
S 48 - 4	7,5	5,5	22,1	12,8	60	58	56	54	50	46	38	28	18	4" dir 6" ET	1358
S 48 - 5	10	7,5	28,2	16,3	74	72	70	68	63	57	48	36	22	6"	1366
S 48 - 6	12,5	9,3	36,4	21	90	88	83	81	76	69	57	43	26	6"	1459
S 48 - 8	15	11	41,5	24	121	118	115	109	101	92	66	57	35	6"	1611
S 48 - 9	20	15	55	32	135	131	128	122	115	103	76	65	40	6"	1736
S 48 - 10	20	15	55	32	150	146	140	136	127	114	96	72	46	6"	1796
S 48 - 12	25	18,5	69,2	40	180	174	169	163	144	137	115	86	53	6"	1987
S 48 - 15	30	22	81,2	47	225	219	208	204	191	171	144	108	67	6"	2232

Ø impulsión: 3" - Outlet Ø : 3"



Tipo Type	Potencia		"A"		Caudal m ³ /h / Flow m ³ /h								Ø Motor	Longitud Lenght	
	HP	KW	III 230	III 400	0	15	30	36	42	48	54	60			66
					Altura m.c.a. / Height w.c.m.										
S 66 - 3	7,5	5,5	22,1	12,8	39	36	32	28	26	22	17	13	9	4" dir 6" ET	1298
S 66 - 4	10	7,5	28,2	16,3	52	48	42	37	33	30	25	19	12	6"	1306
S 66 - 6	12,5	9,3	36,4	21	65	56	53	47	42	36	29	23	15	6"	1459
S 66 - 7	15	11	41,5	24	78	70	63	56	51	44	37	29	19	6"	1551
S 66 - 8	20	15	55	32	104	92	83	75	66	57	49	38	25	6"	1676
S 66 - 9	20	15	55	32	117	105	94	85	76	66	55	43	29	6"	1736
S 66 - 11	25	18,5	69,2	40	130	106	103	93	84	73	61	48	32	6"	1922
S 66 - 14	30	22	81,2	47	156	139	125	111	100	88	73	57	39	6"	2172
S 66 - 19	40	30	111	64,1	233	198	188	169	151	132	110	84	56	6"	2592

Ø impulsión: 3" - Outlet Ø : 3"



■ Aplicaciones:

Electrobombas sumergibles de elevado rendimiento y máxima fiabilidad, aptas para grandes suministros, como pueden ser abastecimientos municipales, obras públicas, usos industriales, grandes riegos, etc...

■ Características constructivas:

Cuerpo impulsión, soporte bomba motor, difusores, turbinas y válvula de retención en fundición de elevada resistencia. Todos los cojinetes y aros en goma anti-arena para asegurar buena resistencia al desgaste y abrasión. Rejilla aspiración y cubrecable en acero inoxidable.

Todas las bombas están diseñadas y preparadas para funcionar en uso continuo con cargas hidroestáticas medianas y elevadas.

Bajo demanda se pueden suministrar con difusores, turbinas, cuerpo aspiración e impulsión en **BRONCE** para trabajar con **AGUA DE MAR** o muy agresiva.

TEMPERATURA MÁXIMA AGUA: 25° C.

MÁXIMA CANTIDAD DE ARENA EN EL AGUA: 25g/m³

TIEMPO MÁXIMO FUNCIONANDO CON BOCA CERRADA: 4 min.

LAS PRESTACIONES SON GARANTIZADAS SEGÚN LOS LÍMITES DE LAS NORMAS ISO 2548 CLASE C.

■ Motor:

Todas estas bombas equipan de serie motor **FRANKLIN** que cumple con la normativa DIN ISO 9001 y cuyas ventajas más destacables son:

Estator hermético en acero inoxidable, acoplamiento internacional tipo Nema. No necesita mantenimiento, todos los cojinetes incluyendo el axial están lubricados por agua.

■ Applications:

Submersible electro pumps with high output and maximum reliability, suitable for large supplies such as municipal supplies, public works, industrial uses, large irrigation, etc.

■ Construction:

Drive body, pump motor support, diffusers, impellers and retention valve in high strength cast iron. All bearings and rings in sand resistant rubber to ensure good resistance to wear and abrasion. Suction grille and cable cover in Stainless Steel.

All pumps are designed and built to work in continuous use with medium and high hydrostatic loads.

To order, they may be supplied with diffusers, impellers, suction and drive bodies in **BRONZE** for work with **SEA WATER** or in highly aggressive conditions.

MAXIMUM WATER TEMPERATURE: 25° C

MAXIMUM AMOUNT OF SAND IN THE WATER: 25 g/m³

MAXIMUM TIME WORKING WITH MOUTH CLOSED: 4 min

THE PERFORMANCES ARE GUARANTEED ACCORDING TO THE LIMITS OF THE ISO 2548 STANDARD CLASS C.

■ Motor:

Pumps fitted as standard with a **FRANKLIN** motor complying with DIN ISO 9001 standards with the following main advantages:

Hermetic stator in stainless steel, international NEMA coupling, no need for maintenance, all bearings, including the axial, are water-lubricated.

Sumergibles Semi-Axiales Serie 6"

Diámetro bomba / Pump Ø 147 mm. - 6"

Tipo Type	Potencia		Caudal m ³ /h / Flow m ³ /h										Ø Motor	Ø Imp.	Longitud Lenght
			12	18	21	24	27	30	33	36	39	42			
	HP	KW	Altura m.c.a. / Height w.c.m.												
S6-32/3	5,5	4	39	37	36	34	32	30	27	24	21	18	6" ENCAPSULADO	ROSCA INT. 3"	1264
S6-32/4	7,5	5,5	52	49	47	45	42	40	36	32	28	24		ROSCA INT. 3"	1481
S6-32/5	10	7,5	65	62	59	56	53	50	45	40	35	30		ROSCA INT. 3"	1531
S6-32/6	10	7,5	78	74	71	67	63	60	54	48	42	36		ROSCA INT. 3"	1633
S6-32/7	12,5	9,2	92	86	83	79	74	69	62	56	49	42		ROSCA INT. 3"	1768
S6-32/8	15	11	105	99	95	90	84	79	71	64	56	48		ROSCA INT. 3"	1902
S6-32/10	20	15	131	123	118	112	105	99	89	80	70	60		ROSCA INT. 3"	2171
S6-32/11	20	15	144	135	130	123	115	109	98	88	77	66		ROSCA INT. 3"	2273
S6-32/12	20	15	157	147	141	134	126	119	107	96	84	72		ROSCA INT. 3"	2375
S6-32/13	25	18,5	170	160	153	145	136	129	116	104	91	78		ROSCA INT. 3"	2543
S6-32/14	25	18,5	183	172	165	157	147	138	124	112	98	84		ROSCA INT. 3"	2645
S6-32/15	30	22	196	184	177	168	157	148	133	120	105	90		ROSCA INT. 3"	2812
S6-32/16	30	22	209	197	189	179	168	158	142	128	112	96		ROSCA INT. 3"	2914
S6-32/17	30	22	223	209	200	190	178	168	151	136	119	102		ROSCA INT. 3"	3016
S6-32/20	40	30	262	246	236	224	210	198	178	160	140	120		ROSCA INT. 3"	3452
S6-32/21	40	30	275	258	248	235	220	208	187	168	147	126		ROSCA INT. 3"	3554
S6-32/22	40	30	288	270	259	246	231	218	196	176	154	132		ROSCA INT. 3"	3656
S6-32/23	40	30	301	283	271	257	241	228	205	184	161	138		ROSCA INT. 3"	3758
S6-32/24	40	30	314	295	283	268	252	237	213	192	168	144		ROSCA INT. 3"	3860
S6-32/26	50	37	340	320	306	291	273	257	231	208	182	156		ROSCA INT. 3"	4432
S6-32/28	50	37	366	344	330	313	294	277	249	224	196	168	ROSCA INT. 3"	4636	

Diámetro bomba / Pump Ø 147 mm. - 6"

Tipo Type	Potencia		Caudal m ³ /h / Flow m ³ /h										Ø Motor	Ø Imp.	Longitud Lenght
			18	24	30	33	36	39	42	45	48	51			
	HP	KW	Altura m.c.a. / Height w.c.m.												
S6-42/2	5,5	4	27	26	24	23	22	20	19	17	16	14	6" ENCAPSULADO	ROSCA INT. 3"	1162
S6-42/3	7,5	5,5	40	38	36	34	32	30	28	26	23	21		ROSCA INT. 3"	1379
S6-42/4	10	7,5	54	51	47	45	43	40	37	34	31	28		ROSCA INT. 3"	1429
S6-42/5	12,5	9,2	67	64	59	57	54	50	47	43	39	35		ROSCA INT. 3"	1564
S6-42/6	15	11	81	76	71	68	64	60	56	51	46	42		ROSCA INT. 3"	1698
S6-42/8	20	15	107	101	95	91	86	80	75	68	62	55		ROSCA INT. 3"	1967
S6-42/9	20	15	120	114	106	102	96	90	84	77	69	62		ROSCA INT. 3"	2069
S6-42/10	25	18,5	134	127	118	113	107	100	93	85	77	69		ROSCA INT. 3"	2237
S6-42/11	25	18,5	147	140	130	124	118	110	102	94	85	76		ROSCA INT. 3"	2339
S6-42/12	30	22	161	152	141	135	128	120	111	102	93	83		ROSCA INT. 3"	2506
S6-42/13	30	22	174	165	153	147	139	130	121	110	100	90		ROSCA INT. 3"	2608
S6-42/15	40	30	201	190	177	169	160	150	139	127	115	103		ROSCA INT. 3"	2942
S6-42/16	40	30	214	203	189	181	171	160	149	136	123	110		ROSCA INT. 3"	3044
S6-42/17	40	30	228	216	200	192	182	170	158	144	131	117		ROSCA INT. 3"	3146
S6-42/18	40	30	241	228	212	203	192	180	167	153	138	124		ROSCA INT. 3"	3248
S6-42/20	50	37	268	254	236	226	214	200	186	170	154	138		ROSCA INT. 3"	3820
S6-42/22	50	37	294	279	259	248	235	220	204	187	170	151		ROSCA INT. 3"	4024

Diámetro bomba / Pump Ø 147 mm. - 6"

Tipo Type	Potencia		Caudal m ³ /h / Flow m ³ /h										Ø Motor	Ø Imp.	Longitud Lenght
			27	40	45	50	55	60	65	70	75	80			
	HP	KW	Altura m.c.a. / Height w.c.m.												
S6-58/2	5,5	4	21	19	18	17,5	17	16	14	13	11	9	6" ENCAPSULADO	ROSCA INT. 3"	1162
S6-58/3	7,5	5,5	32	29	27	26	25	23	21	19	16	14		ROSCA INT. 3"	1379
S6-58/4	10	7,5	43	38	36	35	33	31	28	25	22	18		ROSCA INT. 3"	1429
S6-58/5	12,5	9,2	53	48	45	43	41	39	35	31	27	23		ROSCA INT. 3"	1564
S6-58/6	15	11	64	57	54	52	49	46	42	37	33	27		ROSCA INT. 3"	1698
S6-58/8	20	15	85	76	72	69	66	62	56	50	43	36		ROSCA INT. 3"	1967
S6-58/9	25	18,5	96	86	81	78	74	70	63	56	49	41		ROSCA INT. 3"	2135
S6-58/10	25	18,5	106	95	90	86	82	77	70	62	54	45		ROSCA INT. 3"	2237
S6-58/11	30	22	117	104	99	95	90	85	77	68	60	50		ROSCA INT. 3"	2404
S6-58/12	30	22	127	114	108	103	100	95	87	77	67	56		ROSCA INT. 3"	2506
S6-58/14	40	30	148	133	126	120	115	108	98	87	76	63		ROSCA INT. 3"	2840
S6-58/15	40	30	159	142	135	129	123	115	105	93	81	68		ROSCA INT. 3"	2942
S6-58/16	40	30	170	152	144	138	131	123	112	99	87	72		ROSCA INT. 3"	3044
S6-58/17	40	30	180	162	153	146	139	131	119	105	92	77		ROSCA INT. 3"	3146
S6-58/19	50	37	201	180	171	163	155	146	133	117	102	85	ROSCA INT. 3"	3718	
S6-58/21	50	37	222	200	185	180	172	161	147	130	113	94	ROSCA INT. 3"	3922	

Diámetro bomba / Pump Ø 196 mm. - 8"

Tipo Type	Potencia		Caudal m ³ /h / Flow m ³ /h									Ø Motor	Ø Imp.	Longitud Lenght	
			15	20	30	40	50	60	70	80	90				
	HP	KW	Altura m.c.a. / Height w.c.m.												
S8-70/1	7,5	5,5	24	23	22	21	19	18	15	13	10	6" ENCAPSULADO	4" DIR 6" E-T	DN 100	1305
S8-70/2	12,5	9,2	48	46	44	41	38	35	30	26	20		DN 100	1421	
S8-70/3	20	15	72	69	66	62	57	53	45	39	30		DN 100	1653	
S8-70/4	25	18,5	96	92	88	82	76	70	60	52	40		DN 100	1854	
S8-70/5	30	22	120	115	110	102	95	88	75	65	50		DN 100	2098	
S8-70/7	40	30	168	161	154	143	133	122	105	91	70		DN 100	2498	
S8-70/8	50	37	192	184	176	164	152	140	120	104	80		DN 100	3001	
S8-70/9	60	45	216	207	198	184	171	157	135	117	90		DN 100	3288	
S8-70/10	60	45	240	230	220	205	190	175	150	130	100		DN 100	3423	
S8-70/12	75	55	288	276	264	246	228	210	180	156	120		8"	DN 100	3476
S8-70/14	80	59	336	322	308	287	266	245	210	182	140	8" REBOBINABLE	ENCAPSULADO	DN 100	3876
S8-70/15	90	66	360	345	330	307	285	262	225	195	150		DN 100	4011	
S8-70/16	100	75	384	368	352	328	304	280	240	208	160		DN 100	4236	
S8-70/17	100	75	408	391	374	348	323	297	255	221	170		DN 100	4371	
S8-70/18	125	92	432	414	396	369	342	315	270	234	180	DN 100	4686		
S8-70/19	125	92	456	437	418	389	361	332	285	247	190	DN 100	4821		
S8-70/20	125	92	480	460	440	410	380	350	300	260	200	DN 100	4956		

Sumergibles Semi-Axiales

Serie 8"

Diámetro bomba / Pump Ø 196 mm. - 8"

Tipo Type	Potencia		Caudal m³/h / Flow m³/h										Ø Motor	Ø Imp.	Longitud Lenght
	HP	KW	30	40	50	60	70	80	90	100	110	125			
			Altura m.c.a. / Height w.c.m.												
S8-100/1	7,5	5,5	22	21	21	20	19	18	17	16	14	11	6" ENCAPSULADO	DN 125	1305
S8-100/2	15	11	43	42	41	40	38	36	34	31	28	21			1453
S8-100/3	25	18,5	65	63	62	60	57	54	51	47	42	32			1719
S8-100/4	30	22	86	84	82	80	76	72	68	62	56	42			1919
S8-100/5	40	30	107	105	102	100	95	90	85	78	70	53			2228
S8-100/6	50	37	129	126	123	120	114	108	102	93	84	63			2731
S8-100/7	60	45	150	147	143	140	133	126	119	108	98	74			3018
S8-100/8	60	45	172	168	164	160	152	144	136	124	112	84			3153
S8-100/10	75	55	215	210	205	200	190	180	170	155	140	105	8" ENCAPSULADO	DN 125	3206
S8-100/11	90	66	236	231	225	220	209	198	187	170	154	115	DN 125	3471	
S8-100/12	90	66	258	252	246	240	228	216	204	186	168	126	8" REBOBINABLE	DN 125	3606
S8-100/13	100	75	279	273	266	260	247	234	221	201	182	136		DN 125	3831
S8-100/14	125	92	301	294	287	280	266	252	238	217	196	147		DN 125	4146
S8-100/15	125	92	322	315	307	300	285	270	255	232	210	157		DN 125	4281
S8-100/16	125	92	344	336	328	320	304	288	272	248	224	168	DN 125	4416	



Diámetro bomba / Pump Ø 196 mm. - 8"

Tipo Type	Potencia		Caudal m³/h / Flow m³/h										Ø Motor	Ø Imp.	Longitud Lenght
	HP	KW	60	80	90	100	110	125	140	150	160	180			
			Altura m.c.a. / Height w.c.m.												
S8-150/1	10	7,5	18	17	17	16	16	15	13	12	11	6	6" ENCAPSULADO	DN 125	1253
S8-150/2	20	15	36	34	33	32	31	29	26	23	21	11			1518
S8-150/3	30	22	54	51	50	48	47	44	39	35	32	17			1784
S8-150/4	40	30	72	68	66	64	62	58	52	46	42	22			2049
S8-150/5	50	37	90	85	83	80	78	73	65	58	53	28			2596
S8-150/6	60	45	108	102	99	96	93	87	78	69	63	33			2883
S8-150/7	75	55	126	119	115	112	108	101	91	81	74	39	8" ENCAPSULADO	DN 125	2801
S8-150/8	80	59	144	136	132	128	124	116	104	92	84	44		DN 125	3066
S8-150/9	90	66	162	153	148	144	139	130	117	103	95	50	8" REBOBINABLE	DN 125	3201
S8-150/10	100	75	180	170	165	160	155	145	130	115	105	55		DN 125	3426
S8-150/11	125	92	198	187	181	176	170	159	143	126	115	61		DN 125	3741
S8-150/12	125	92	216	204	198	192	186	174	156	138	126	66	8" ENCAPSULADO	DN 125	3876
S8-150/13	150	110	234	221	214	208	201	188	169	149	136	72		DN 125	4247
S8-150/14	150	110	252	238	231	224	217	203	182	161	147	77		DN 125	4382
S8-150/15	150	110	270	255	247	240	232	217	195	172	157	83		DN 125	4517

Diámetro bomba / Pump Ø 253 mm. - 10"

Tipo Type	Potencia		Caudal m ³ /h / Flow m ³ /h										Ø Motor	Ø Imp.	Longitud Lenght
	HP	KW	Altura m.c.a. / Height w.c.m.												
			80	100	110	125	140	150	160	170	180	190			
S10-160/1	25	18,5	40	38	36	35	33	31	29	27	22	20	6"	DN 175	1673
S10-160/2	50	37	79	75	73	69	65	62	59	54	44	40			ENCAPSULADO
S10-160/3	75	55	118	112	108	104	98	93	88	80	67	60	8"	DN 175	2539
S10-160/4	100	75	157	149	145	138	130	123	117	107	89	80			REBOBINABLE
S10-160/5	125	92	196	186	181	173	163	154	146	134	111	100	10"	DN 175	3279
S10-160/6	148	110	236	224	217	207	195	185	175	160	133	120			REBOBINABLE
S10-160/7	177	132	275	261	253	242	228	216	204	187	155	140	10"	DN 175	3538
S10-160/8	215	150	314	298	289	276	260	246	233	213	177	160			REBOBINABLE
S10-160/9	255	165	356	338	324	311	293	279	261	239	198	180	REBOBINABLE	DN 175	4138

Diámetro bomba / Pump Ø 253 mm. - 10"

Tipo Type	Potencia		Caudal m ³ /h / Flow m ³ /h										Ø Motor	Ø Imp.	Longitud Lenght
	HP	KW	Altura m.c.a. / Height w.c.m.												
			100	120	140	160	180	200	220	230	240	250			
S10-190/1	30	22	38	37	35	33	30	27	24	22	20	18	6"	DN 175	1738
S10-190/2	60	45	76	73	70	66	61	55	47	44	40	36			ENCAPSULADO
S10-190/3	90	66	115	110	105	98	91	82	71	65	59	53	8"	DN 175	2669
S10-190/4	125	92	153	147	140	131	121	109	95	87	79	71			REBOBINABLE
S10-190/5	148	110	191	183	175	164	152	137	119	109	99	89	10"	DN 175	3068
S10-190/6	177	132	229	220	210	197	182	164	142	131	119	107			REBOBINABLE
S10-190/7	255	165	267	257	244	230	212	191	166	152	139	125	REBOBINABLE	DN 175	3798

Diámetro bomba / Pump Ø 253 mm. - 10"

Tipo Type	Potencia		Caudal m ³ /h / Flow m ³ /h										Ø Motor	Ø Imp.	Longitud Lenght
	HP	KW	Altura m.c.a. / Height w.c.m.												
			150	180	200	220	240	260	280	300	315	350			
S10-280/1	40	30	29	28	27	26	25	24	23	21	20	16	6" ENCAPSULADO	DN 175	1868
S10-280/2	75	55	59	55	53	51	50	48	46	42	40	31	8"	DN 175	2369
S10-280/3	100	75	88	83	80	77	75	71	69	64	60	47			REBOBINABLE
S10-280/4	150	110	118	111	106	103	100	95	92	85	80	63	10"	DN 175	2898
S10-280/5	175	130	147	139	133	129	125	119	115	106	100	79			REBOBINABLE

Tubería Flexible para bombas sumergidas

Serie "RYLBRUN"



Racord desmontable para RYLBRUN 25



Racord de expansión

■ Aplicaciones:

La tubería flexible RYLBRUN está fabricada a base de materiales de alta calidad y resistencia, cuyas características, hacen ideal para la instalación de bombas sumergibles en tiempo muy reducido, con mínimos medios humanos y mínimo despliegue de maquinaria para su instalación.

■ Características:

- Facilidad y rapidez en la manipulación (montaje y desmontaje).
- Facilidad de transporte y almacenamiento por su ligereza.
- Larga duración de la instalación, no le afecta la corrosión.
- Reduce la pérdida de carga y el golpe de ariete.
- Autoportante. No necesita elementos auxiliares de sujeción.
- Continua. Hasta 500 metros de tubería en una sola pieza.

■ Applications:

The RYLBRUN flexible pipe is manufactured with very high quality and resistant material. Its characteristics makes it ideal for fast installations of deep well pumps.

■ Characteristics:

- Easy and fast to manipulate.
- Easy to transport and store.
- Long lasting installation, no affected by corrosion.
- Reduces water hammer impact.
- Improves performance.
- Continuous without junctions, up to 500 meters.

TIPO TYPE	DIÁMETRO DIAMETER	CAUDAL MÁXIMO MAX. FLOW	PRESIÓN MÁXIMA MAX. PRESSURE	TIPO DE RÁCORES CONNECTIONS TYPE
RYLBRUN 25 AZUL	1"	3.500 l/h	6 bar	2 x DESMONTABLE 1"
RYLBRUN 32 GRIS	1 1/4"	7.000 l/h.	10 bar	2 x EXPANSIÓN 1 1/4"
RYLBRUN 32 NEGRA	1 1/4"	7.000 l/h.	20 bar	2 x EXPANSIÓN 1 1/4"
RYLBRUN 2" GRIS	2"	20.000 l/h.	10 bar	2 x EXPANSIÓN 2"
RYLBRUN 2"	2"	20.000 l/h.	30 bar	2 x CÓNICO 2"
RYLBRUN 3"	3"	48.000 l/h.	25 bar	2 x CÓNICO 3"
RYLBRUN 4"	4"	70.000 l/h.	25 bar	2 x CÓNICO 4"

Todos los rácores son en acero inoxidable AISI 316. / All the connections are made in Stainless Steel AISI 316.



■ Aplicaciones:

Motores blindados fabricados según normas ISO 9001 en baño de agua, totalmente en acero inoxidable AISI-304 y con acoplamiento para bomba de tipo NEMA.

Los motores de 4" monofásicos necesitan de condensador exterior.

Todos los motores se suministran con uno o dos tramos de cable en función del tipo de arranque del motor.

■ Características constructivas:

Estátor encapsulado o rebobinable

Retén mecánico y protector para un mejor funcionamiento contra la arena.

Permite montaje tanto vertical como horizontal.

Motores de 6", 8" y 10" pueden solicitarse para arranque directo o para arranque estrella-triángulo

■ Tipos:

Motores de 4" encapsulados monofásicos (hasta 3CV) y trifásicos a 230V (hasta 7.5CV) ó 400V (hasta 10CV)

Motores de 6" encapsulados (hasta 60CV) o rebobinables (hasta 45CV)

Motores de 8" encapsulados (hasta 200CV) o rebobinables (hasta 125CV)

Motores de 10" rebobinables (hasta 250CV)

Bajo demanda pueden solicitarse voltajes especiales y/o constructivamente en AISI-316.

■ Applications:

Hermetic motors manufactured complying with DIN and ISO 9001 standards. Filled international NEMA coupling. Fully made in stainless steel 304. The 4" single phase motors require external capacitor.

All motors are supplied with one or two wires depending on the start mode.

■ Construction:

Encapsulated or rewindable stator.

Seal and protector for a better performance against sand.

Horizontal and vertical installation.

Motors from 6" to 10" can be supplied direct start or star delta.

■ Types:

Motors 4" encapsulated single phase (up to 3HP)

- Three phase 230V up to 7.5HP

- Three phase 230V up to 10HP

Motors 6" encapsulated up to 60HP and rewindable up to 45HP

Motors 8" encapsulated up to 200HP and rewindable up to 125HP

Motors 10" rewindable up to 250HP

Motores Sumergibles SACI 4", 6", 8" y 10"

Serie "SACI"



■ Aplicaciones:

Motores eléctricos SACI para bombas sumergibles con acoplamiento de 4" y también de 6", 8" y 10".

Los motores de 4" contienen en su interior un baño de aceite líquido dieléctrico atóxico, apto para instalaciones de todo tipo, y especialmente indicado en instalaciones con tensión de red baja, y en instalaciones de depósito abierto, gracias a su fácil refrigeración. Disponen además de un diafragma que permite la compensación de la presión interior del motor con la del pozo.

Los motores de 6", 8" y 10" son todos rebobinables, y disponen de cojinetes radiales y axiales de doble sentido de giro lubricados por agua.

■ Características principales:

Fabricado completamente en acero inoxidable AISI-304
Estator rebobinable

Acoplamiento standard NEMA

Cable de alimentación con conector estanco
 Máximo número de arranques: 150 arranques/hora (motores de 4")

Inmersión máxima: 100 metros bajo el agua (motores de 4")

Protección IP68, aislamiento clase E

Máxima temperatura del agua: 40° C

■ Applications:

Electrical motors SACI type for submersible pumps with 4", and 6", 8" and 10" with NEMA coupling.

The 4" motors are filled with non toxic dielectric oil. This motor is suitable for all types of applications and specially recommended in installations with low net tension, and in tank pools, thanks to its easy cooling ability. The 6", 8" and 10" motors are all rewindable, and equipped with radial and axial bearings of dual rotation, and water lubricated.

■ Construction:

Manufactured fully in stainless steel 304.

Rewindable stator

Standard NEMA coupling

Wire with resin filled connector

Maximum number of starts: 150 per hour (only 4" motors)

Maximum immersion: 100 meters under the water (only 4" motors)

Protection IP68, Isolation class E

Maximum water temperature: 40°C

Serie "COMPACTA"	98
Serie "FEKA"	99
Serie "GRINDER-GM/GT"	100
Serie "HT"	102
Serie "MG-M"	103
Serie "VG-VT" Vortex	106
Serie "DRENAG"	108
Serie "SUM"	109
Serie "BD-BV-BC-BM" Bronce	110
Serie "XD-XV-XC-XM" Inoxidable	111
Serie "ANTIDEFAGRANTE"	112
Estaciones Automáticas "FEKAFOS"	113
Instalación Mediante Zócalo de Acoplamiento	114
Accesorios Aguas Fecales	114



■ Aplicaciones:

Las robustas y portátiles electrobombas de la serie compacta que incorporan turbina desplazada tipo Vortex están diseñadas específicamente para la evacuación de aguas cargadas que contengan gases o bien sólidos blandos en suspensión.

Son ideales para su uso en fosas sépticas, industrias, hospitales, etc...

Debe trabajar con el motor, al menos, parcialmente sumergido.

■ Características Constructivas:

Cuerpo bomba, carcasa motor, porta cojinetes y tapa motor en fundición de hierro GG25. Tornillería en acero inoxidable tipo A2. Juntas tóricas en nitrilo. Eje bomba en acero inoxidable AISI 420. Sello mecánico del lado bomba en carbono de silicio y superior es un retén de aceite.

Atención: La bomba **COMPACTA 5 M AUT.** se entrega con interruptor de nivel (automático) suelto, que debe ser conectado a la caja de conexiones incorporada de serie.

■ Motor:

Asíncrono a 2.850 r.p.m. monofásico y trifásico, aislamiento clase F. Grado de protección IP-68 e incorpora motoprotector en el bobinado. Incorpora de serie 10 mts. de cable H07 RNF.

Temperatura máxima del agua en continuo + 40° C y en intermitente + 80° C. Valores de Ph entre 6 y 11.

■ Applications:

The robust, portable electropumps of the compact series that include a displaced Vortex type Impeller are specifically designed for evacuating loaded waters that contain soft solids in suspension. They are ideal for use in septic tanks, industries, hospitals, etc...

Must work with motor partially immersed.

■ Construction:

Pump body, motor housing, bearing holder and motor lid in GG25 cast iron. Bolts in A2 stainless steel. O-rings in nitril. Pump shaft in AISI 420 stainless steel. Mechanical seal on the pump side in silicon carbide and an oil seal at the top. The compacta 5 M AUT includes a switch level apart from the pump.

■ Motor:

Asynchronous at 2,850 rpm, single and triple phase, class F insulation. IP-68 protection. Includes 10 metres of H07 RNF cable as standard.

Maximum water temperature in continuous + 40° C and + 80° C in intermittent.

Ph values between 6 and 11.

Tipo Type	Con. µF	Volt.	Potencia		"A"		Altura m.c.a. / Height w.c.m.										Ø Paso Sólido	Ø Imp.	
			HP	KW	II 230	III 400	2	4	5	6	8	10	12	14	16	18			
							Caudal m³/h / Flow m³/h												
COMPACTA 1 M Aut.	7,5	230M	0,4	0,28	1,9	-	8	4,5	2,9	1,5								30	1 1/4"
COMPACTA 2 M Aut.	16	230M	0,75	0,55	4,2	-	10,5	8,1	6,3	4,5	0,5							40	1 1/2"
COMPACTA 2T	-	400T			-	1,5													
COMPACTA 3 M Aut.	20	230M	1	0,75	5,1	-	13,5	11,7	10	9	5,4	0,5						40	1 1/2"
COMPACTA 3T	-	400T			-	1,9													
COMPACTA 22 M Aut.	16	230M	0,75	0,55	4,2	-	12,6	5,4	2,9	1								50	2"
COMPACTA 22T	-	400T			-	1,5													
COMPACTA 32 M Aut.	20	230M	1	0,75	5,1	-	20	10,8	7,2	3,6								50	2"
COMPACTA 32T	-	400T			-	1,9													
COMPACTA 4 M Aut.	30	230M	1,5	1,1	8,3	-	27	22,5	20	16,2	9	1,8						50	2"
COMPACTA 4T	-	400T			-	2,8													
COMPACTA 5 M Aut.	40	230M	2	1,5	9,3	-	36	32,4	29	26	21,6	16,5	10,8	3,6				50	2"
COMPACTA 5T	-	400T			-	3,6									32,4	27	24,5		
COMPACTA 6T	-	400T	3	2,2	-	5,2	41,5	38,1	36,4	34,2	29,2	25,2	19,8	14,4	7,6	0,5	50	2"	

PARA MAS INFORMACION CONSULTAR NUESTRO CATALOGO TECNICO DE BOMBAS FECALES
CHECK OUR TECHNICAL CATALOGUE OF WASTE WATER PUMPS FOR MORE INFORMATION



FEKA VS



FEKA 1400-1800

■ **Aplicaciones:**

Bomba centrífuga sumergible idónea para el desagüe de aguas sucias y cargadas en general. Incorporan interruptor de nivel para su funcionamiento automático en versión monofásica (excepto FEKA 1400 M).

■ **Características Constructivas:**

FEKA VS: Cuerpo bomba, cuerpo motor, turbina y eje motor en acero inoxidable. Doble sello mecánico y cámara intermedia de aceite tóxico. Equipada con 10 metros de cable.

FEKA 1400 / 1800: Cuerpo, carcasa motor y turbina en fundición de hierro. Cierre mecánico de carburo silicio. Tornillería, extensión eje motor y asa en acero inoxidable. Cámara de cierre mecánico inspeccionable bañada en aceite.

■ **Motor:**

Motor en seco, refrigerado mediante líquido bombeado. Todos los motores incorporan de serie una protección termo amperimétrica.
Temperatura del líquido: de + 0° C a + 35° C
Inmersión máxima 10 mts.

■ **Applications:**

Submersible centrifugal pump in stainless steel that is ideal for draining dirty waters and waters that are generally loaded.

■ **Construction:**

FEKA VS: Pump body, mechanical closing lid, filter and filter lid, motor housing, external housing and lid with handle in AISI 304 stainless steel. Motor shaft in AISI 316 stainless steel. Vortex Impeller in AISI 304 micro-fusion stainless steel.

Double mechanical seal with intermediate oil chamber (silicon carbide lower and carbon - aluminium upper).

FEKA 1400 - 1800: Vortex system pump, pump body, motor housing and Impeller in high strength cast iron. Mechanical seal in carbon and ceramic. Bolts, motor shaft extension and handle in stainless steel. Mechanical seal chamber, oil bathed inspectionable.

■ **Motor:**

ADry motor, cooled with the pumped liquid.
Temperature of the liquid: from + 0° C to + 35° C. IP-68.
Class F.
MAXIMUM IMMERSION 10 METERS.

Tipo Type	Cond. µF	Potencia		"A"		Altura m.c.a. / Height w.c.m.										Paso Solido mm.	Ø Imp.
						HP	KW	II 230	III 400	2	4	5	6	8	10		
		Caudal m³/h / Flow m³/h															
FEKA VS 550 M Aut	12,5	0,75	0,55	4,2	-	16	12	8	6							50	2"
FEKA VS 750 M Aut	16	1	0,75	5,2	-	24	19	15	13	8	0,5					50	2"
FEKA VS 1000 M Aut	25	1,36	1	6,6	-	28	24	22	20	15	8,5	0,5				50	2"
FEKA VS 1000T	-			-	2,5												
FEKA VS 1200 M Aut	30	1,6	1,2	8,6	-	30	28	25	21	15	8	0,5				50	2"
FEKA VS 1200T	-			-	3,4												
FEKA 1400 M	40	1,5	1,1	8,5	-	28	25	23	17	12	6	0,15				38	2"
FEKA 1800T	-	2	1,5	-	3,7	32	28	25	22	17	11	5	0,15			38	2"



■ Aplicaciones:

Bomba de tipo sumergible con triturador, para el servicio civil e industrial, de bombeado de aguas sucias procedentes de servicios higiénicos en albergues, campamentos, hospitales y de aguas residuales procedentes del zoo, industria conservera, etc.

En caso de trabajar a baja altura, recomendamos instalar una válvula de bola para provocar el trabajo dentro de la curva.

■ Características Constructivas:

Cuerpo bomba, cuerpo motor y turbina en fundición de alta resistencia. Dispositivo triturador en acero inoxidable obtenido por microfundición y endurecido para obtener dureza y tenacidad. Disco cierre de hierro. Tornillería y extensión eje motor en acero inoxidable. Cierre mecánico en carburo de silicio.

■ Motor:

Asíncrono absolutamente estanco con aislamiento clase F=155° C. y grado de protección IP-68, la refrigeración del motor efectúa por el líquido en el cual está sumergida la bomba.

La bomba GRINDER 1400 M incluye cuadro de protección de serie. No incluye sondas.

Instalar siempre una válvula de corte para ajustar la altura manométrica mínima de la bomba.

■ Applications:

Submersible pumps with grinder cutting system for civil and industrial use. To pump waters from sanitary services in boarding houses, camp sites, hospitals, and residual waters from zoos, conserve industries, etc...

Esphere valve recommended for low pressure work.

■ Construction:

Body, motor housing and Impeller in high strength cast iron.

Grinder mechanism in stainless steel obtained by microfusion and hardened to achieve hardness and tenacity. Iron sealing disk. Bolts and motor shaft extension in stainless steel. Mechanical seal chamber in silicon carbide.

■ Motor:

Submersible, asynchronous, continuous service, tight seal cladded. Rotor mounted with ball bearings calculated to guarantee duration and silent working. CEI standard. IP-68 protection. F insulation.

Includes Single phase electrical control panel (only for 1400 M Grinder). Without float switches.

Control containing the permanent capacitor and the mechanism for increasing the starting torque.

Install always a closing valve to adjust the minimum manometric high of each pump.

Tipo Type	P2 (HP)	"A"		r.p.m.	Altura m.c.a. / Height w.c.m.									
		II 230	III 400		5	6	7	8	9	10	12			
		Caudal m³/h / Flow m³/h												
GRINDER 1400 M	1,5	8,7	-	2.850										
GRINDER 1800 T	2	-	3,8	2.850										
GM 32-2 149 M Aut	1,2	6	-	2.850	12,6	12,2	11,5	10,4	9,7	9	6,5			
GT 32-2 149 T		-	2,5	2.850										
GM 32-2 150 M Aut	2	8,9	-	2.850		12,6	11,9	10,8	9,7	9	6,8			
GT 32-2 150 T		-	3	2.850										
GM 32-2 155 M Aut	2,5	11	-	2.850				14,4	13,7	12,9	11,5			
GT 32-2 155 T		-	4,2	2.850										
GT 32-2 160 T	3	-	5	2.850				15,5	15,1	15,1	14,8			
GT 65-2 165 T	4,5	-	7,8	2.850										
GT 65-2 170 T	6	-	9,5	2.850										
GT 65-2 175 T	8,5	-	13,7	2.850								28,8	28,6	
GT 65-2 180 T	10,5	-	16,2	2.850										
GT 65-2 185 T	13	-	20	2.850										



Altura m.c.a. / Height w.c.m.																	Paso sólidos Free Pass mm.	Ø IMP. Outlet
14	16	18	20	23	26	29	32	35	38	41	44	47	50	56	62			
Caudal m³/h / Flow m³/h																		
	9	7,8	6,5	5	1,8												4	2"
		10	8,5	7	5	1											4	2"
	5	2,9	0,9														6	2"
	4,3	3,6	1,8														6	2"
	9,7	7,9	6,1	5,4	2,4												6	2"
	14,4	13,7	12,6	10,8	9	5,4	1,8										6	2"
				18	15,8	12,2	7,2	3,6									8	DN 65
				20,5	19,8	18	14,4	12,2	7,2	2,9							8	DN 65
	28,2	27,8	27,5	27,2	27	25,2	21,7	18	12,2	7,9	5	1,8					10	DN 65
				29,9	29,9	29,9	29,5	28,4	26,6	23	19,4	14,4	9,4	5			10	DN 65
								28,6	28,1	27,6	27,3	27	21,6	18	10,8	1,8	10	DN 65



■ Aplicaciones:

Las electrobombas de la serie HT están especialmente diseñadas para la elevación de aguas claras y ligeramente cargadas o arenosas a grandes alturas. Especialmente indicadas para fuentes, riegos, pozos, cisternas, equipos contra incendios, etc....

■ Características constructivas:

Carcasa, tapa motor, cuerpo bomba y turbina en fundición G-25 de alta resistencia; eje rotor y tornillería en inox.; juntas tóricas en goma nitrílica; cierre mecánico autolubricado mediante cámara intermedia de aceite, cierre mecánico superior en cerámica-grafito y cierre mecánico inferior en carburo de silicio-vitón.

■ Motor:

Asíncrono, en baño de aceite dieléctrico y atóxico, absolutamente estanco con aislamiento tipo F=155°C y grado de protección IP-68; de serie con 10 mts. de cable de neopreno HO7-RN-F.

Todos los motores de esta serie son a 2.850 r.p.m.
Temperatura máxima del agua bombeado en continuo + 40° C y en intermitente + 80° C. Valores Ph: entre 6-11.

Profundidad máxima de inmersión: 20 mts.

Densidad máxima del líquido: 1.100 Kg/ m³

■ Applications:

The electropumps of the HT series are especially designed to raise clear and lightly loaded or sandy waters to great heights. Particularly recommended for fountains, irrigation, wells, cisterns, fire fighting equipment, etc...

■ Construction:

Housing, motor lid, pump body and Impeller in G-25 high strength cast iron; rotor shaft and bolt work in stainless steel, o-rings in nitril rubber, mechanical seal self-lubricated by intermediate oil chamber, upper mechanical seal in graphite ceramic and lower in silicon carbide - viton.

■ Motor:

Asynchronous, in dielectric and atoxic oil bath only in the seal chamber, absolutely sealed with F=155° C sealing and IP-68 protection. Standard with 10 metres of HO7-RN-F neoprene cable.

All motors are standard at 2,850 rpm.

Maximum water temperature pumped in continuous + 40° C and in intermittent + 80° C.

Ph values: between 6-11.

Maximum immersion: 20 metres.

Tipo Type	Potencia		"A"	r.p.m	Altura m.c.a. / Height w.c.m.																Paso solidos Free Pass mm.	Ø IMP. Outlet
	HP	KW			Trif. 400 V	4	6	10	14	16	18	20	22	24	26	30	34	38	42	46		
	Caudal m ³ /h / Flow m ³ /h																					
HT 50-2 C. 500	2	1,5	3,7	2.850	26	23	17	10	7,2	3,6	1										16	2"
HT 50-2 C. 501	3	2,2	5,2	2.850	31	29	25	19	16	12	9	5,8	2,5	1							16	2"
HT 65-2 C. 502	4	3	7,4	2.850	31	31	26	22	18	14	11	8,3	6,1	2,9	1						10	DN 65
HT 65-2 C. 503	5,5	4	8,8	2.850	35	34	32	30	28	26	24	22	19	16	11	6,1	1				10	DN 65
HT 65-2 C. 504	7,5	5,5	12,5	2.850	53	50	46	41	37	35	32	29	26	23	17	11	4,3				10	DN 65
HT 65-2 C. 505	10	7,5	15,5	2.850	64	62	59	55	53	50	48	45	43	40	35	29	22	15	7,2	1,8	10	DN 65

**PARA MAS INFORMACION CONSULTAR NUESTRO CATALOGO TECNICO DE BOMBAS FECALES
CHECK OUR TECHNICAL CATALOGUE OF WASTE WATER PUMPS FOR MORE INFORMATION**



■ Aplicaciones:

Las electrobombas de la Serie "MG - M", por su robustez y diseño compacto, son las idóneas para el bombeo de aguas residuales como pueden ser fangos biológicos, etc., que contengan sólidos en suspensión. Especialmente indicadas para el sector civil, industrial y sanitario.

Gracias al diseño de sus diferentes componentes así como a los dispositivos de seguridad que incorporan los motores, estas bombas son aptas para un trabajo continuo.

Debe trabajar con el motor completamente sumergido.

MÁXIMA TEMPERATURA DEL LÍQUIDO: 50° C

■ Características constructivas:

Carcasa, tapa motor, cuerpo bomba y turbina en fundición G-25 de alta resistencia; eje rotor y tornillería en inox.; juntas tóricas en goma nitrílica; cierre mecánico superior en cerámica-grafito y cierre mecánico inferior en carburo de silicio-vitón.

■ Motor:

Asíncrono, absolutamente estanco con aislamiento tipo F=155° C y grado de protección IP-68; de serie con 10 mts. de cable de neopreno H07-RN-F.

La refrigeración del motor se efectúa por el líquido en el cual esta sumergida la bomba.

■ Applications:

The robustness and compact design of the electro-pumps of the "M-MG" series make them ideal for pumping waste waters such as biological silts, etc. that contain solids in suspension of up to 140 x 140 mm. Particularly recommended for the civil, industrial and sanitary sectors. Thanks to the design of the open mono-channel, multichannel Impellers,

The upper part of the Impeller includes a toothed section that prevents particles and filaments from adhering to the shaft.

Must work with motor fully submerged.

MAXIMUM TEMPERATURE OF THE LIQUID: 50° C

■ Construction:

Housing, motor lid, pump body and Impeller in G-25 high strength cast iron; rotor shaft and bolt work in stainless steel, o-rings in nitril rubber, mechanical seal self-lubricated by intermediate oil chamber, upper mechanical seal in graphite ceramic and lower in silicon carbide - viton.

■ Motor:

Asynchronous, class F=155° C insulation and IP-68 protection. Standard with 10 metres of HO7-RN-F neoprene cable.

These pumps works 2,850 rpm - 1,450 rpm – 970 rpm.

Tipo Type	P2 (HP)	"A"	r.p.m.	Altura m.c.a. / Height w.c.m.													
				2	3	4	5	6	7	8	9	10	12	14			
				Caudal m ³ /h / Flow m ³ /h													
MONOCANAL 2.850 r.p.m.																	
M 65/2 C. 236	2	3,9	2850	43,2	41,3	39,6	37,1	34,6	32,6	28,8	26,1	23,4	16,2	8			
M 65/2 C. 237	3	5,1	2850	66,2	63,1	58,3	53,2	46	43,8	41,4	39	36	30,6	25,2			
M 65/2 C. 247	5,5	9	2850	68,4	66		63,4	61,5	58,3	56,2	54	50,8	46,8	39,6	32,4		
M 80/2 C. 257	10	14,1	2850			162	159,1	154,6	149,8	144	139,1	134,7	122,4	111,2			
M 80/2 C. 267	15	21	2850				191	186,4	179,9	175,7	173,6	170	163,4	150,3			
M 80/2 C. 268	20	31	2850									212,4	204,5	196,8			
MG213R1M3-M40AA2	13,4	28	2850			100	99	98	96	93	91	88	84	80			
MG213R1M1-M40AA3	20,7	34,3	2850														
MONOCANAL 1.450 r.p.m.																	
M 80/4 C. 242	1,7	3,2	1450		66,6	61,2	52,2	45	34,2	25,2	12,6						
M 80/4 C. 244	3	5	1450	111,6	100,8	93,6	82,8	75,6	66	54	41,4	27					
M 80/4 C. 245	4	6,4	1450	133,2	124,2	117	108	99	88,2	77,4	64,8	54	27	9			
M 100/4 C. 243	2	4,2	1450	97,2	84,6	72	63	46,8	36,8	27	12,6	3,6					
M 100/4 C. 244	3	4,7	1450	108	99	90	81	72	60,5	46,8	36	25,2	7,2				
M 100/4 C. 245	4	6,5	1450	126	118,8	111,6	100,8	91,8	81,8	72	63	48,6	27	10,8			
M 100/4 C. 255	5,5	7,8	1450	147,6	140,4	129,6	120,2	111,6	100,8	90	83	64,8	43,2	14,4			
M 100/4 C. 256	7,5	11,6	1450		165,6	158,4	149,5	140,4	129,6	118,8	110	100,8	79,2	57,6			
M 150/4 C. 258	10	17,5	1450	284,4	273,6	261	244,8	230,4	216	198	180	162	126	86,4			
M 150/4 C. 260	13,5	21,3	1450				216	208,8	201,6	194,4	187,2	180	158,4	133,2			
M 150/4 C. 263	22	33,2	1450				263	259	256	252	248	245	234	223,2			
M 150/4 C. 264	16,5	23,4	1450				327,6	288	270	252	230,4	208,8	162	108			
M 150/4 C. 265	22	32	1450				370,8	342	324	306	299	281	245	205			
M 150/4 C. 275	27	40	1450				406,8	396	381,6		360	346	331	295	256		
M 150/4 C. 280	34	48	1450							421,2	396	374,4	328	306			
M 150/4 C. 285	40	56	1450											468			
M 150/4 C. 290	48	68	1450														
M 150/4 C. 295	60	81	1450														
MULTICANAL 2.850 r.p.m.																	
MG213R3C2-P40AA2	20,7	33	2850									230	223	213	202		
MG213R3C1-P40AA2	21,4	33	2850														
BICANAL 1.450 / 950 r.p.m.																	
MG410R2C2-P80AA2	6,5	9,3	1450			180	160	145	125	110	85	58	24				
MG413R2C2-P80AA2	10,9	24,4	1450	270	260	250	240	230	212	195	188	175	145	108			
MG613R2C2-S80AA2	9,3	16,6	950	330	305	288	260	240	220	196	170	140	80	20			
MG618R2C1-S100AA2	15	25	950	475	458	430	400	380	360	330	300	280	220	142			
MG418R2C2-S100AA2	38	63,3	1450									490	480	440	400		
MG418R2C1-S80AA2	38	63,3	1450														
MG420R2C3-S100AA2	43,8	79	1450		600	585	575	560	542	525	520	505	480	450			
MG420R2C1-S100AA2	53,4	79	1450		650	640	630	605	595	580	570	560	540	510			
MG420R2C1-T102AA2	60,5	79	1450		975	945	910	890	865	840	830	800	760	715			
MG425R2C3-V105AA2	86	138	1450		1340	1300	1270	1250	1220	1190	1150	1130	1100	1040			
MG425R2C1-V105AA2	114	145	1450		1450	1425	1400	1380	1350	1330	1300	1275	1220	1190			
MULTICANAL 950 r.p.m.																	
MG618R2C3-T102AA2	10,6	25	950	520	480	440	400	365	320	280	220	180	45				
MG618R2C1-T102AA2	15,5	25	950	600	570	550	515	475	440	410	370	330	250	140			
MG618R3C4-V105AA2	29,4	54	950	880	840	810	800	760	720	680	640	570	440	250			
MG618R3C3-V105AA2	31,4	54	950	1020	980	920	900	850	800	720	680	640	550	400			
MG625R4C2-W140AA2	55,8	83	950	1650	1590	1550	1470	1400	1350	1270	1200	1150	1000	800			
MG625R4C1-W140AA2	65,6	101	950	1860	1800	1760	1720	1620	1550	1480	1400	1350	1200	1020			

Tablas de selección rápida / Numerical Selection table

Serie "MG - M"



Altura m.c.a. / Height w.c.m.															Paso sólidos Free Pass mm.	Ø IMP. Outlet	
16	18	20	23	26	29	35	38	41	44	47	50	55	60	65			75
Caudal m³/h / Flow m³/h																	
																40	DN 65
	16,2	12,2	5,4													40	DN 65
	23,4	12,6	5,4	1												45	DN 65
	100,8	88,5	72	57,6	43,2	28,8	7,2									55	DN 80
	140,4	134,2	122,4	110,9	93,6	75,6	39,6	25,2	3,6							33	DN 80
	187,2	176,1	166	153,3	139	122,4	93,6	78,2	61,2	39,6	14,4					33	DN 80
	75	72	67	58	52	44	25	12	3,5							40	DN 80
											54	45	36	18		40	DN 80
																75	DN 80
																75	DN 80
																75	DN 80
																90	DN 100
																90	DN 100
	1															90	DN 100
	1															90	DN 100
	32,4	14,4														90	DN 100
	43,2															100	DN 150
	111,6	90	72	46,8	25,2	3,6										80	DN 150
	209	187,2	162	122,4	90	43,2	14									80	DN 150
	65	18														110	DN 150
	162	115	68,4	28,8												110	DN 150
	234	194,4	144	90	50,4	3,6										120	DN 150
	284,4	248,4	216	158,4	115,2	46,8										120	DN 150
	428,4	385,2	345,6	284,4	223,2	166	86,4	54								110	DN 150
		522	450	385,2	297	260	158,4	118,8	82,8	18						120	DN 150
				512	432	360	234	172,8	126	93,6	61,2	18				130	DN 150
	194	185	180	160	140	125	88	65	38							40	DN 100
									80	52	13					40	DN 100
																80	DN 100
	72	25														80	DN 100
																80	DN 100
	60															100	DN 150
	365	325	288	225	160	40										100	DN 150
				320	244	180	80	20								80	DN 150
	420	395	355	300	240	155										100	DN 150
	480	450	420	380	325	250	105									100	DN 150
	640	600	560	480	400	320	90									102	DN 200
	980	930	860	800	670	570	300	130								105	DN 250
	1120	1080	1020	970	850	750	570	430	300	200						105	DN 250
																102	DN 200
	30															102	DN 200
																105	DN 250
	100															105	DN 250
	600	340														140	DN 300
	840	620	440													140	DN 300



■ Aplicaciones:

Las electrobombas de la Serie "VG - VT", por su robustez y diseño compacto, son las idóneas para el bombeado de aguas residuales como pueden ser fangos biológicos, etc., que contengan sólidos en suspensión de hasta 130 x 130 mm. Especialmente indicadas para el sector civil, industrial y sanitario. Gracias al diseño de sus turbinas vortex es posible bombear líquidos que contengan gases la parte superior de la turbina incorpora un especial dentado que previene la adhesión de filamentos al eje y sello mecánico.

Debe trabajar con el motor completamente sumergido.

TEMPERATURA MÁXIMA DEL LIQUIDO: 50° C

■ Características constructivas:

Carcasa, tapa motor, cuerpo bomba y turbina en fundición G-25 de alta resistencia; eje rotor y tornillería en inox.; juntas tóricas en goma nitrílica; cierre mecánico superior en cerámica-grafito y cierre mecánico inferior en carburo de silicio-vitón.

■ Motor:

Asíncrono, absolutamente estanco con aislamiento tipo F=155° C y grado de protección IP-68; de serie con 10 mts. de cable de neopreno H07-RN-F.

La refrigeración del motor se efectúa por el líquido en el cual esta sumergida la bomba.

■ Applications:

The robustness and compact design of the electropumps of the "VG - VT" series make them ideal for pumping waste waters such as biological silts, etc. that contain solids in suspension of up to 130 x 130 mm. Particularly recommended for the civil, industrial and sanitary sectors. Thanks to the design of the vortex Impellers, it is possible to transfer liquids with abrasive particles or gases. The upper part of the Impeller includes a toothed section that prevents particles and filaments from adhering to the shaft.

Must work with motor fully submerged.

MAXIMUM TEMPERATURE OF THE LIQUID: 50° C

■ Construction:

Housing, motor lid, pump body and Impeller in G-25 high strength cast iron; rotor shaft and bolt work in stainless steel, o-rings in nitril rubber, mechanical seal self-lubricated by intermediate oil chamber, upper mechanical seal in graphite ceramic and lower in silicon carbide - viton.

■ Motor:

Asynchronous, in dielectric and atoxic oil bath only in the seal chamber, absolutely sealed with F=155° C sealing and IP-68 protection. Standard with 10 metres of HO7-RN-F neoprene cable. All motors are standard at 2,850-1,450-970 rpm.

Tipo Type	P2 (HP)	"A"	r.p.m.	Altura m.c.a. / Height w.c.m.										
				2	3	4	5	6	7	8	9	10		
				Caudal m ³ /h / Flow m ³ /h										
VORTEX 1.450 r.p.m.														
VT 80/4 C. 341	1,5	2,6	1450	43,2	37,8	30,6	19,8	7,2						
VT 80/4 C. 342	1,7	3,2	1450	52,2	46,8	39,6	32,4	21,6	7,2					
VT 80/4 C. 343	2,3	3,9	1450	79,2	61,2	50,4	36	25,2	10,8					
VT 80/4 C. 344	3	5,2	1450	97,2	86,4	72	61,2	50,4	39,6	28,8	16,2	5,4		
VT 80/4 C. 345	4	7,2	1450	115,2	100,8	90	79,2	70,2	61,2	50,4	39,6	28,8		
VT 100/4 C. 349	3	5,2	1450	97,2	75,6	57,6	43,2	30,6	14,4					
VT 100/4 C. 350	4	7,2	1450	115,2	97,2	82,8	72	61,2	46,8	36	21,6	7,2		
VT 100/4 C. 355	5,5	9,2	1450	136,8	122,4	108	93,6	82,8	72	57,6	46,8	36		
VT 100/4 C. 356	8	12,5	1450	154,8	144	136,8	127,8	118,8	108	97,2	86,4	72		
VT 100/4 C. 358	10	15,5	1450	172,8	165,6	154,8	147,6	138,6	129,6	122,4	111,6	100,8		
VT 100/4 C. 362	16	23,8	1450										154,8	151,2
VT 100/4 C. 363	20	30,4	1450										198	190,8
VT 100/4 C. 375	27	41	1450											
VT 100/4 C. 380	34	51	1450											
VT 150/4 C. 385	48	68	1450											
VT 150/4 C. 390	60	85	1450								399,6	370,8	342	
VT 150/4 C. 395	75	92	1450											
VORTEX 2.850 r.p.m.														
VG213R3V4-M80AA2	21,3	33	2850					150	145	138	131	125		
VG213R6V2-M50AA2	21,3	33	2850											
VG213R6V1-M50AA2	21,3	33	2850											



G

Altura m.c.a. / Height w.c.m.														Paso solidos Free Pass mm.	Ø IMP. Outlet	
12	14	16	18	20	23	26	29	32	35	38	41	44	47			
Caudal m³/h / Flow m³/h																
															75	DN 80
															75	DN 80
															80	DN 80
															80	DN 80
9															80	DN 80
															100	DN 100
															100	DN 100
72															90	DN 100
50,4	14,4														90	DN 100
79,2	55,8	28,8													90	DN 100
133,2	111,6	86,4	54	10,8											90	DN 100
176,4	158,4	136,8	115,2	86,4	21,6										90	DN 100
				144	115,2	82,8	43,2	3,6							90	DN 100
				190,8	154,8	118,8	79,2	36	3,6						90	DN 100
				90											130	DN 150
288	244,8	198	144	90											130	DN 150
414	370,8	324	284,4	244,8	180	108	7,2								130	DN 150
				414	306	252	194,4	115,2	54	10,8					130	DN 150
118	112	105	98	85	79	70	54	36	20	2					80	DN 80
							76	57	41	26	10				50	DN 80
									59	44	28	14	2		50	DN 80



■ Aplicaciones:

Bombas sumergibles idóneas para el drenaje de aguas turbias y arenosas que contengan sólidos de máximo 12 mm. de diámetro (FEKA 1400-1800).

■ Características constructivas:

DRENAG 1000 / 1200 M/T: Cuerpo bomba, turbina, rejilla, base de aspiración, asa y carcasa de motor en acero inoxidable AISI-304. Eje motor en acero inoxidable AISI-316. Doble sello mecánico y cámara intermedia de aceite atóxico. Equipada con 10 mt. de cable HO7-RNF.

DRENAG 1400 M / 1800 T: Cuerpo, carcasa motor y turbina en fundición de hierro de alta resistencia. Disco cierre turbina recubierto de goma antiabrasiva (sólo para Drenag). Filtro de aspiración en acero inoxidable. Cierre mecánico de carburo de silicio. Tornillería, extensión eje motor y asa en acero inoxidable. Cámara de cierre mecánico inspeccionable bañada en aceite.

■ Motor:

A 2.850 r.p.m., asíncrono estanco con aislamiento clase F=155° C. y grado de protección IP-68, la refrigeración del motor se efectúa por el líquido en el cual está sumergida la bomba. Inmersión máxima 10 mts.

■ Applications:

Submersible electro pump ideal for drainage and dirty-sandy waters, containing solids no larger than 12 mm. of diameter (FEKA 1400-1800).

■ Construction:

DRENAG 1000 / 1200 M/T: Pump body, impeller, filter, base, handle and casing in stainless steel AISI 304. Shaft in stainless steel AISI 316. Double mechanical seal with intermediate oil chamber. Supplied with 10 mts of HO7-RNF cable.

DRENAG 1400 M / 1800 T: Pump body and motor casing in high resistant cast iron. Impeller plate protected with rubber (only Drenag). Filter in stainless steel AISI 304. Mechanical seal in silicium carbide. Shaft, bolts and handle in stainless steel. Oil chamber for mechanical seal.

■ Motor:

At 2,850 r.p.m., asynchronous closed with isolation type F (155 ° C) IP-68 protection. Refrigeration of the motor through the liquid surrounding. Maximum immersion 10 mts.

Tipo Type	Cond. µF	Potencia		"A"		Altura m.c.a. / Height w.c.m.														Paso sólidos Free Pass mm.	Ø IMP. Outlet	
		HP	KW	II 230	III 400	3	4	5	6	7	8	9	10	12	14	16	18	20				
						Caudal m³/h / Flow m³/h																
DRENAG 1000 M	25	1,36	1	6	-	21	19,5	18	16,5	15	13,5	12	10	6	2					10	11/2"	
DRENAG 1000 M Aut				-	2,4																	
DRENAG 1000 T	-			-	2,4																	
DRENAG 1200 M	30	1,6	1,2	7,5	-	25	23,5	22	20,5	19	17	15	13,5	10	5,5	2					10	11/2"
DRENAG 1200 M Aut				-	3,2																	
DRENAG 1200 T	-			-	3,2																	
DRENAG 1400 M	40	1,5	1,1	9,2	-			32	30	29	27	25	23	20	15	10	2				12	2"
DRENAG 1800 T	-	2	1,5	-	4,4			37	35	34	33	31,5	30	28	26	21	17	10	1		12	2"

Sumergible de Drenaje Serie "SUM"



■ Aplicaciones:

Electrobombas sumergibles, concebidas para la función de agotamiento y drenaje en inundaciones, en la construcción de los cimientos de edificios y en la perforación de pozos y similares, donde sea necesario el trasiego de aguas con mezclas de barros y arenas. Lleva un guardamotor magneto-térmico incorporado, que puede ser rearmado desde el exterior mediante pulsador.

■ Características Constructivas:

Bomba construida en fundición de alta calidad en Silumin. Rodetes construidos en fundición especial con dureza de 60 Rockwell C. Cuerpos de bomba y turbinas recubiertos totalmente de goma proporcionando la máxima eficacia al desgaste.

■ Motor:

A 2.850 r.p.m. refrigerado mediante el paso del agua bombeada a través de una doble cámara. Cambio de tensión desde el exterior, mediante cable especial. Doble junta mecánica de Metal Duro de gran resistencia, que asegura la estanqueidad bomba-motor.

■ Applications:

Submersible electropumps conceived for evacuating and draining in floods, in foundation building and in drilling wells and similar, where it is necessary to transfer waters with mixtures of mud and sands.

It has a built-in magnetothermal motor protector with a button on the outside for rearming.

■ Construction:

Pump built in high quality Silumin cast iron. Impeller in a special cast iron with a hardness of 60 Rockwell C. Pump body and impellers entirely covered with rubber, giving maximum wear efficiency.

■ Motor:

At 2,850 rpm. Cooled by means of the water pumped through a double chamber. Voltage changed from the outside by means of a special cable. Double mechanical seal in high strength Hard Metal to ensure that the pump motor is properly sealed.

Tipo Type	Potencia HP				Altura m.c.a. / Height w.c.m.																	Ø Paso Sólido mm.	Ø Imp. DN					
	"A"		Caudal m ³ /h / Flow m ³ /h																									
	II 230	III 400	II 230	III 400	2	4	6	8	10	12	14	16	18	20	23	26	29	32	35	38	41			44	50			
SUM 19 M	2	-	10	-																							10	2"
SUM 19 T	-	2	-	3,6	50	44	37	30	23	16	8,5															10	2"	
SUM 20 T	-	2,5	-	4,1			24	22	20	18	16,5	15	11	8												8	2"	
SUM 21 T	-	4	-	6,7			48	45	43	38	33	30	26	23	16	9										8	3"	
SUM 22 T*	-	8	-	13			99	97	95	87	78	72	66	60	49	38	11									8	3"	
SUM 23 T	-	4	-	6,7					25	24	23	22	21	20	19	17	16	14	12	10	7					8	2"	
SUM 24 T*	-	8	-	13					44	43	42	41	40	38	36	34	32	29	25	22	19	15	5			8	3"	
SUM 25 T	-	2,5	-	4,1	50,4	45	40	34	28	20,5	14															8	3"	
SUM 26 T	-	4	-	6,7	68	65	60	55	50	40	31															8	3"	



■ Aplicaciones:

Las electrobombas sumergibles en bronce marino B10 están indicadas para el bombeo de líquidos provenientes del sector marino, alimentario, productos químicos y petroquímicos.

■ Características constructivas:

Cuerpo bomba, cuerpo motor en bronce marino B10, turbina y tornillería en acero inoxidable AISI-316, eje en acero inoxidable AISI-316L, juntas en goma nitrilica, cierre mecánico superior en cerámica-grafito y cierre mecánico inferior en carburo de silicio.

Serie "BD" - Drenaje

Serie "BV" - Vortex

Serie "BC y BM" - Multicanal / Monocanal

■ Motor:

Asíncrono absolutamente estanco con aislamiento clase F= 155° C y grado de protección IP-68, la refrigeración del motor se efectúa por el líquido en el cual está sumergida la bomba.

■ Applications:

Submersible pump in marine bronze B-10, to pump liquids from marine, chemical, petrol industry.

■ Construction:

Pump body, motor casing in marine bronze B-10. Shaft, impellers and nuts in stainless steel AISI 316. O-ring in nitril. Upper mechanical seal in ceramic-graphite. Lower mechanical seal in silicium carbide.

"BD Serie" - Drainage

"BV Serie" - Vortex

"BC & BM Serie" - Multichannel / Monochannel

■ Motor:

Asynchronous, completely sealed, with class F= 155° C isolation. IP-68 protection.

Tipo Type	HP	"A"	Opc. Motor Antidif.	r.p.m.	Altura m.c.a. / Height w.c.m.														Ø Paso Solido mm.	Ø Imp. DN
					2	4	6	8	10	12	14	16	18	20	23	29	35	41		
					Caudal m ³ /h / Flow m ³ /h															
DRENAJE																				
B271T6D4-J6KA0	1,1	5,0	SI	2850	22	19,5	17	14,2	10,5	5									6	DN 40
B271T6D1-J6KA0	2,3	5,0	SI	2850		28	27	25	23,5	21,5	19	17	14,2	12	7				6	DN 40
B209T6D2-J7KA0	3,0	6,1	SI	2850					27,6	24,5	21,5	17	14,5	9,5					7	DN 40
B209T6D1-J7KA0	4,0	6,1	SI	2850							28	24	22	17	10				7	DN 40
B210R6D3-J7KA2	5,5	10,5	SI	2850							34	33	30	28	24	16	2		7	DN 40
B210R6D1-J7KA2	7,2	10,5	SI	2850											33	26	18	8	7	DN 40
VORTEX																				
B206T6V1-D30HA0	0,4	1,2	NO	2850															30	1 1/4"
B206M6V1-D30HB1 M	0,4	3,1	NO	2850	11	7,3	3												30	1 1/4"
B271T3V1-K48KA0	1,7	5,0	SI	2850		29	23	18	12	6									48	DN 50
B471T6V1-L50KA0	1,7	3,1	SI	1450	45	34	23	10											50	DN 65
B409T6V1-M50KA0	2,7	5,6	SI	1450	74	62	46	30	4										50	DN 80
MULTICANAL / BICANAL																				
B271T1M1-L40KA0	2,7	5,0	SI	2850		50	45	40	33	27	20	13	6						40	DN 65
B209T3C3-L30KA0	3,0	6,1	SI	2850		80	72	60	48	30	4								30	DN 65
B209T3C2-L30KA0	4,0	6,1	SI	2850				76	66	56	46	30	9						30	DN 65
B210R3C2-M30KA2	5,9	10,5	SI	2850	119	112	104	96	88	80	69	60	48	32					30	DN 80
B210R3C1-M30KA2	7,5	10,5	SI	2850					104	97	89	80	72	60	44				30	DN 80



■ Aplicaciones:

Las electrobombas sumergibles en acero inox AISI-316 están indicadas para bombeo de líquidos agresivos y corrosivos, en particular para el drenaje de líquidos provenientes en plantas químicas.

■ Características constructivas:

Cuerpo bomba, cuerpo motor y turbina en acero inoxidable AISI-316; eje motor y tornillería en inox, juntas tóricas en vitón, cierre mecánico superior en cerámica-grafito y cierre mecánico inferior en carburo de silicio con juntas en vitón.

Serie "XD" - Drenaje

Serie "XV" - Vortex

Serie "XC y XM" - Multicanal / Monocanal

■ Motor:

Asíncrono absolutamente estanco con aislamiento clase F= 155° C y grado de protección IP-68, la refrigeración del motor se efectúa por el líquido en el cual está sumergida la bomba.

■ Applications:

Submersible pump in stainless steel AISI 316, to pump aggressive liquids and corrosive. Mostly used to drain liquids from chemical plants.

■ Construction:

Pump body, motor casing, impeller, shaft and nuts in stainless steel AISI 316.

"XD Serie" - Drainage

"XV Serie" - Vortex

"XC & XM Serie" - Multichannel / Monochannel

■ Motor:

Asynchronous, completely sealed, with class F= 155° C isolation. IP-68 protection.

Tipo Type	HP	"A"	Opc. Motor Antidef.	r.p.m.	Altura m.c.a. / Height w.c.m.														Ø Paso Solido mm.	Ø Imp. DN	
					2	4	6	8	10	12	14	16	18	20	23	29	35	41			44
					Caudal m³/h / Flow m³/h																
DRENAJE																					
X271T6D4-J6LA4	1,1	3,2	SI	2850	22	19,5	17	14,2	10,5	5									6	DN 40	
X271T6D1-J6LA4	2,3	5,0	SI	2850		28	27	25	23,5	21,5	19	17	14,2	12	7				6	DN 40	
X209T6D2-J7LA4	3,0	6,1	SI	2850					27,6	24,5	21,5	17	14,5	9,5					7	DN 40	
X209T6D1-J7LA4	4,0	6,1	SI	2850								28	24	22	17	10			7	DN 40	
X210R6D3-J7LA5	5,5	10,5	SI	2850							34	33	30	28	24	16	2		7	DN 40	
X210R6D1-J7LA5	7,2	10,5	SI	2850											33	26	18	8	7	DN 40	
X211R7D3-G8LA5	6,8	14,1	NO	2850							48	44	40	37	32	18			8	2"	
X211R7D2-G8LA5	7,5	14,1	NO	2850												38	25		8	2"	
X211R7D1-G8LA5	10,0	14,1	NO	2850													42	30	19	8	2"
VORTEX																					
X271T3V1-K48LA4	1,7	5,0	SI	2850		29	23	18	12	6									48	DN 50	
X471T6V1-L50LA4	1,7	3,1	SI	1450	45	34	23	10											50	DN 65	
X409T6V1-M50LA4	2,7	5,6	SI	1450	74	62	46	30	4										50	DN 80	
MULTICANAL / MONOCANAL																					
X271T1M1-L40LA4	2,7	5,0	SI	2850		50	45	40	33	27	20	13	6						40	DN 65	
X209T3C3-L30LA4	3,0	6,1	SI	2850		80	72	60	48	30	4								30	DN 65	
X209T3C2-L30LA4	4,0	6,1	SI	2850				76	66	56	46	30	9						30	DN 65	
X210R3C2-L30LA5	5,9	10,5	SI	2850	119	112	104	96	88	80	69	60	48	32					30	DN 80	
X210R3C1-L30LA5	7,5	10,5	SI	2850					104	97	89	80	72	60	44				30	DN 80	



■ Aplicaciones:

Bombas para aguas fecales con turbina de tipo Vortex, especialmente indicadas en instalaciones de atmósfera explosiva, o que presentes cierto riesgo de deflagración.

■ Características constructivas:

Bomba en hierro fundido EN-GJL-250, turbina en aleación EN-GJL-250+Níquel, cable eléctrico de neopreno H07RN-F, eje en acero inoxidable AISI-420B, juntas en nitrilo, tornillería de Clase A2 / AISI-304, sello mecánico de Carburo de silicio.

Tipo de construcción antidefragante EEX d IIb T3 (según normas ATEX).

■ Motor:

Motor eléctrico asíncrono, grado de protección IP68, aislamiento clase H.

Máxima temperatura del agua: 40°C.

Arranques máximos: 15 arranques/hora.

■ Applications:

Sewage water pumps with Vortex impeller, designed for installations with explosive atmosphere, or with some risk of explosion.

■ Construction:

Cast iron pump EN-GJL-250, impeller alloy EN-GJL-250 + Nickel, neoprene cord H07RN-F, AISI-420B stainless steel shaft, nitrile o-rings, AISI-304 Class 2 bolts, ceramic carbide mechanical seal.

Anti explosion construction EEX d IIb T3 (follows ATEX regulation).

■ Motor:

Asynchronous motor, IP-68 protection, isolation class H.

Maximum water temperature: 40°C

Maximum starts: 15 starts / hour.

Tipo Type	Voltaje Voltage	r.p.m.	HP	KW	AMP.	Altura m.c.a. / Height w.c.m.														Paso Solido mm.	Ø Imp.
						2	3	4	5	6	7	8	9	10	11	12	14				
						Caudal m³/h / Flow m³/h															
G271M3V1-K50AA6	230 M.	2.850	1,5	1,1	6,5	37	34	32	29	25	22	19	15	14	10	8	3	50	DN 50		
G271T3V1-K50AA6	400 T.	2.850	1,7	1,2	2,9	37	34	32	29	25	22	19	15	14	10	8	3	50	DN 50		

Estaciones Automáticas de Recogida y Elevación de Aguas Fecales

Serie "FEKAFOS"



FEKABOX 100



FEKABOX 200



FEKABOX 280



FEKAFOS 550

■ Estaciones automáticas para almacenamiento y elevación de aguas residuales civiles e industriales hacia el alcantarillado. Incluyen un depósito de polietileno de alta densidad de 100 lts. / 200 lts. / 280 lts / 550 lts. y con los siguientes accesorios según modelo:

Estas estaciones de bombeo no incluyen bombas

■ **KIT FEKABOX 100**

(Para 1 sola bomba) incluye: Depósito 100 lts., preparado para conectar la bomba y el cuadro eléctrico, incluye accesorios.

Puede usarse con las siguientes bombas: NOVA/Feka y Compacta 1 - 2 - 3 - 22 - 32.

Medidas: A x B x H / 700 x 380 x 500 mm.

■ **KIT FEKABOX 200**

(Para 1 sola bomba) incluye: Depósito 200 lts., preparado para conectar la bomba y el cuadro eléctrico, incluye accesorios.

Puede usarse con las siguientes bombas: Feka 600 y Compacta.

Medidas: A x B x H / 850 x 555 x 735 mm.

■ **KIT FEKABOX 280**

(Para 1 sola bomba) incluye: Depósito 280 lts., 1 minizócalo de anclaje ya instalado. Puede usarse con las siguientes bombas:

Compacta, Feka 1400/1800, Grinder 1400/1800. Medidas: A x B x H / 800 x 640 x 745 mm.

■ **KIT FEKAFOS 550**

(Para 2 bombas) incluye: Depósito 500 lts., 2 minizócalos de anclaje, 3 interruptores de nivel.

Puede usarse con las siguientes bombas: Compacta, Feka 1400/1800, Grinder 1400/1800.

Medidas: A x B x H / 920 x 1.100 x 745 mm.

Accesorios Opcionales:



■ Automatic stations for storing and rising civil and industrial residual waters to the drain network:

■ **FEKABOX 100 (only for 1 pump)**

Container of 100 lit. made of high density polyethylene, to use with one pump. With accesories. This faecal station does not includes the pump.

■ **FEKABOX 200 (only for 1 pump)**

Container of 200 lit. made of high density polyethylene, to use with one pump. Stainless steel bedplate for the pump, and 2" connections. This faecal station does not includes the pump.

■ **FEKABOX 280 (only for 1 pump)**

Container of 280 lit. made of high density polyethylene, to use with one pump. Includes automatic coupling finger and connection accesories for pumps in 2". This faecal station does not includes the pump

■ **FEKAFOS 550 (for 2 pumps)**

Container of 550 lit. made of high density polyethylene, to use with two pumps. Includes two automatic coupling fingers and connection accesories for pumps in 2". Also includes 3 mercury floating switches.

This faecal station does not includes the pumps.

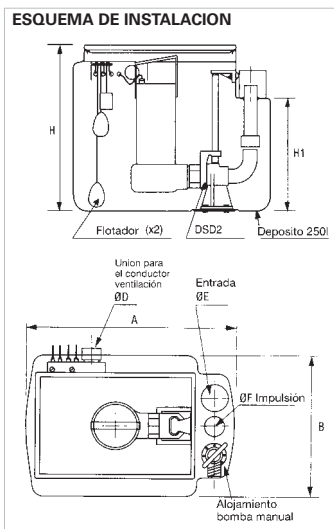

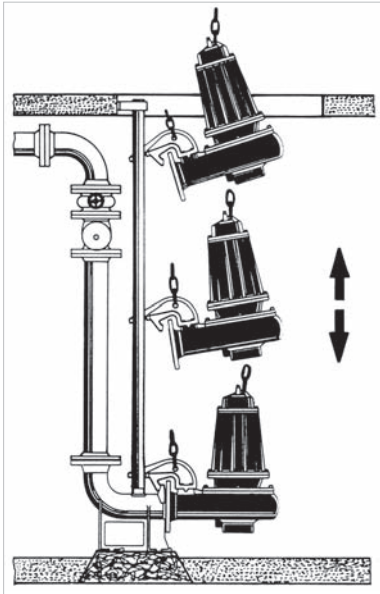

Instalación Fija Sumergida mediante Zócalo de Acoplamiento.

La instalación de las electrobombas para aguas fecales mediante zócalo de anclaje representa una solución racional y cómoda de cara a un posterior y continuado mantenimiento, ya que que la bomba se puede extraer fácilmente del pozo, a través de una cadena, y posteriormente volver a colocarla.

El zócalo de anclaje debe ser fijado en el fondo del depósito, unido a la tubería de impulsión, y a través de dos tubos guía fijados en la parte interior de la trampilla de salida, se desplaza la electrobomba hasta llegar a la conexión exacta de las bridas, de zócalo y bomba, permitiendo una unión totalmente estanca gracias al peso de la bomba.

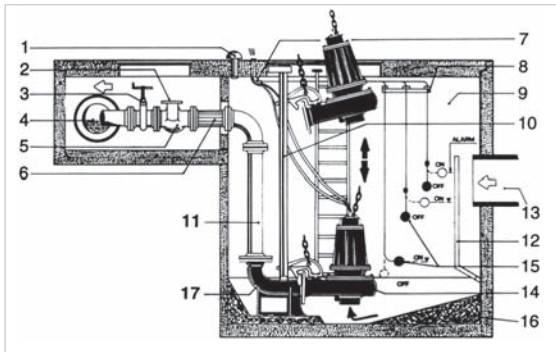

SISTEMA DE INSTALACIÓN

1. Tubo de ventilación
2. Comprobador de válvula
3. Válvula de paso
4. Desagüe
5. Válvula de retención
6. Manguito unión
7. Protector cable
8. Guía int. de nivel
9. Depósito de llenado
10. Tubo guía
11. Tubería de impulsión
12. Pre-cámara de llenado
13. Colector de llenado
14. Electrobomba
15. Reguladores de nivel
17. Zócalo de anclaje

Serie "ACCESORIOS AGUAS FECALES"

Válvulas de retención de bola para aguas fecales paso total:

Modelos: Roscadas: 1 1/2" - 2" - 2 1/2"
Bridas: DN 65, DN 80, DN 100, DN 150



Full passage ball retention valves for waste waters:

Types: Threaded: 1 1/2" - 2" - 2 1/2"
Flange: DN 65, DN 80, DN 100, DN 150

Brida con codo 90°

Modelos: DN 65, DN 80, DN 100, DN 150
(Para utilizar en instalaciones sin zócalo de acoplamiento).



Elbow with flange

Types: DN 65, DN 80, DN 100, DN 150
(To use in instalations without fix coupling).

Interruptor de Nivel.

Modelo: Eco-Mercury
Temp. Máx.: 60° C
Voltaje Máx.: 400 V.
Intensidad Máx.: 6 Amp.
Longitud cable: 6 metros.



Switch level.

Type: Eco-Mercury
Máx. Temp.: 60° C
Máx. Voltage: 400 V.
Máx. Intensity: 6 Amp.
Cable lenght: 6 meters.

Serie "B"	116
Serie "BE"	117
Serie "DRILL"	118
Serie "KIT BE-25 M - CONTADOR"	118
Serie "COLOMBO"	119
Serie "MD 75"	120
Serie "GPC-GPS"	121
Bombas de Arrastre Magnético y Vaciado de Bidones	122



Todos los tipos indicados deben funcionar con líquidos sin residuos sólidos, siendo imprescindible el empleo del filtro. Para alturas de aspiración mayores de las tabuladas (máx. 7 m.) debe utilizarse válvula de retención. Para otras características de servicio rogamos nos consulten.

All types indicated must work with liquids without solid residues, and the use of a filter is essential. For suction heights exceeding those in the tables (maximum 7 metres), a retention valve must be used. Please consult us for other service characteristics.

CORRIENTE ALTERNA: bombas autoaspirantes para: AGUA-VINO-GAS OIL-PETROLEO-AGUA DE MAR, etc.
ALTERN CURRENT: Selfpriming pumps for: WATER-WINE-GASOIL-SEA WATER, etc.

Tipo Type	HP	Voltaje	Altura Asp. m	"A"	Caudal m ³ /h / Flow m ³ /h							Ø tubo pipe mm
					0,9	1,1	1,3	1,5	3,9	4,2	4,5	
					Altura m.c.a. / Height w.c.m.							
B-25	1/8	11 230	2,5	1,5	25	15	10	0				16
B-75-A	1/2		3,5	2,2					10	5	0	32

Bomba autoaspirante para: ACEITE / Selfpriming pump for oil.

Tipo Type	HP	Voltaje	Altura Asp. m	"A"	Caudal m ³ /h / Flow m ³ /h						Ø tubo / pipe mm
					0,24	0,36	0,48	0,6	0,72	0,84	
					Altura m.c.a. / Height w.c.m.						
B-14	1/4	11 230	5	1,6	25	20	15	10	5	0	20

CORRIENTE CONTINUA / Continuous current:

Tipo Type	Voltaje	"A"	Altura Asp. m	Caudal m ³ /h / Flow m ³ /h												Ø tubo pipe mm
				0,36	0,48	0,6	0,8	1,2	1,7	1,8	2,1	2,7	3	4,3	4,5	
				Altura m.c.a. / Height w.c.m.												
B-12-C	12 ó 24	10-5	0,3	25	15	7	0								12	
B-30		8-4	2					8	5	2					20	
B-50-C		10-5	4								4	3	0		25	
B-75-C GAS-OIL		20-10	4											5	0	30

Tipo Type	W	Voltaje	Caudal m ³ /h / Flow m ³ /h				Equipo de Presión
			0,1	0,6	1	2,5	
			Altura m.c.a. / Height w.c.m.				
C.C.1	240	12 ó 24	20	15	10	2	C.C. 1/4



BOMBA Y EQUIPO PRESIÓN CORRIENTE CONTINUA.

Pequeño grupo indicado para disponer de agua a presión en embarcaciones, caravanas, etc... donde sólo se disponga de C.C.

PUMP AND BOOSTER SET WITH CONTINUOUS CURRENT.

Little group indicate to have pressure in boats, caravans, etc.

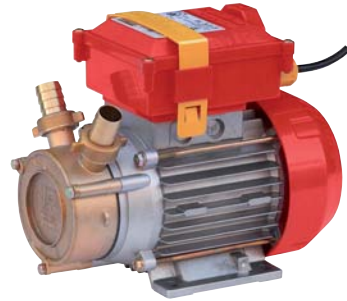
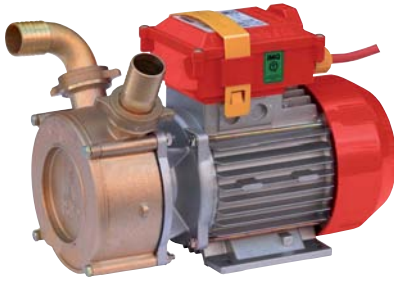

■ **Aplicaciones:**

SERIE BE: Electrobomba autoaspirante de anillo líquido, adecuada para el trasiego de: AGUA DE MAR, ACEITE, GAS-OIL, etc...

Equipadas con asa, rácores para manguera y cable con clavija de enchufe por su concepción de bomba portátil. AUTOASPIRANTE HASTA 8 METROS.

■ **Características constructivas:**

Cuerpo bomba, rácores y turbina en bronce según Norma UNI 5075 inoxidable para evitar bloqueos. Eje en acero inoxidable 18/8 y cierre mecánico "Corteco" con muelle de acero inoxidable y elastómero especial.

Temperatura máxima del agua: 35° C

Temperatura máxima ambiente: 35° C

Presión máxima admitida: 6 Kg/cm²

■ **Motor:**

Cerrado de ventilación externa, de servicio continuo y grado de protección IP-44

LA BOMBA BE 20M - BE 25 M PUEDEN SER CON IP-55 PARA TRABAJAR CON GAS-OIL

TODAS LAS BOMBAS BE SON REVERSIBLES

■ **Applications:**

A liquid ring self-driving pump, suitable for the transfer of SEA WATER, OIL, DIESEL FUEL, etc...

Fitted with a handle, connections for hose and cable with plug for its portable facility.

The AC versions are with reversible flow with a turn direction switch.

SELF-PRIMMING UP TO 8 METRES.

■ **Construction:**

Pump body, connectors and impeller in stainless bronze according to UNI 5075 to prevent blockage.

Shaft in 18/8 stainless steel and "Corteco" mechanical seal with stainless steel spring and special elastomer.

Maximum water temperature: 35° C

Maximum ambient temperature: 35° C

Maximum pressure admitted: 6 Kg/cm²

■ **Motor:**

Sealed with external ventilation, continuous service and IP-44 protection.

THE BE 20M - BE 25 M PUMPS MAY BE WITH IP-55 PROTECTION, FOR WORKING WITH DIESEL.



Tipo Type	Cond. µF	r.p.m.	Voltaje Voltage	Potencia		Caudal m ³ /h / Flow m ³ /h										Ø Asp. Imp.	
				HP	KW	0,3	0,9	1,2	1,5	2,4	3,6	4,5	5,4	6,3			
						Altura m.c.a. / Height w.c.m.											
BE 20-M E	10	2.900	II 230	0,5	0,37	18	10	7	1								20
BE 25-M	14			0,6	0,45	14	12	11	9	1							25
BE 30-M E	25	1.450	III 400	1	0,74	14	14	14	13	11	6	4	1				30
BE 30-T	-																
BE 40-M E	32		II 230	1,2	0,9	16	16	15	14	10	8	7	4	1			40
BE 40-T	-		III 400														

Tipo Type	r.p.m.	Voltaje Voltage C.C.	Potencia W	Caudal m ³ /h / Flow m ³ /h								Ø Asp. Imp.					
				0,3	0,6	0,9	1,1	1,25	1,5	1,75	2						
				Altura m.c.a. / Height w.c.m.													
MARINA 20-12	3.200	12	480	19	17	12	9	5	3	2							20
MARINA 20-24		24															

■ Aplicaciones:

Electrobomba autoaspirante de anillo líquido adecuada para el trasiego de: **VINO, AGUA DE MAR, ACEITE, GASOIL, etc.**

APTA PARA ADAPTAR A TALADRO.

■ Características constructivas:

Cuerpo bomba, racores y turbina en bronce según norma UNI 5075, inoxidable para evitar bloqueos. Eje en acero inoxidable 18/8 y cierre mecánico "Corteco" con muelle de acero inoxidable y elastómero especial.

MAXIMA TEMP. AMBIENTE:
MAXIMA TEMP. LIQUIDO BOMBEADO:
PRESION MAXIMA ADMITIDA:

40°C.
60°C.
6 bar.



■ Applications:

A self-drive liquid ring electropump suitable for transferring WINE, SEA WATER, OIL, DIESEL, etc.

■ Construction:

Pump body, connectors and impeller in bronze according to UNI 5075, stainless steel to prevent blockage. Shaft in 18/8 stainless steel and "Corteco" mechanical seal with stainless steel spring and special elastomer.

MAXIMUM AMBIENT TEMPERATURE: 40° C
MAXIMUM TEMPERATURE PUMPED LIQUID: 60° C
MAXIMUM PRESSURE ADMITTED: 6 bar

Tipo Type	Watts		lts./h. max		Alt. max. m.c.a.		Asp. vert. m.c.a.		Asp. horiz. m.c.a.		Rumorosidad db		Ø Mang. mm.
	1500 r.p.m.	3000 r.p.m.	1500 r.p.m.	3000 r.p.m.	1500 r.p.m.	3000 r.p.m.	1500 r.p.m.	3000 r.p.m.	1500 r.p.m.	3000 r.p.m.	1500 r.p.m.	3000 r.p.m.	
DRILL 20	220	350	720	2100	9	30	2	6	10	40	71	75	20

Serie "KIT BE-25 M - CONTADOR"

■ Aplicaciones:

Este moderno y actual kit es la solución más adecuada para medir líquidos de uso privado como gasoil, vino, agua dulce y salada, soluciones químicas, leche, etc., cuando se hace necesario garantizar caudales relativamente elevados a presiones relativamente bajas.

■ Características constructivas:

Kit compuesto por:

- Bomba BE 25-M
- Kit impulsión apto para combustibles y líquidos alimentarios.
- Contador de polipropileno con entrada y salida en latón, con contador total y parcial. Presión máxima 3 bar.
- Bancada soporte
- Filtro de aspiración

PRECISION: ±5%
KIT VALIDO SOLO PARA USO PRIVADO



■ Applications:

This modern kit is the best solution for measuring liquids in private use, such as diesel, wine, soft and salt water, chemical solutions, milk, etc...when it is necessary to guarantee relatively high flows at relatively low pressures.

■ Construction:

A kit comprising:

- BE 25-M pump
- Drive kit suitable for fuels and food liquids.
- Polypropylene counter with brass inlet and outlet, total and partial counter. Maximum pressure 3 bar.
- Support bench
- Suction filter

PRECISION: ±5%
KIT ONLY SUITABLE FOR PRIVATE USE.

Tipo Type	Tensión Tension	Potencia Power	m³/h	Dimensiones Dimensions
KIT BE-25-Contador	II 230	0,5 CV.	2,7	350 x 200 x 480



■ Aplicaciones:

Este filtro para vino con bomba incorporada de la serie BE facilita muchísimo, dentro del ambiente doméstico, la operación de filtrado de impurezas de líquidos como vino, agua, etc....

Este kit incorpora una bomba modelo BE 20 M (con un sólo sentido de giro).

El caudal de esta bomba es de 360 lts./h y una máxima potencia absorbida de 30 Watt.

■ COMO SE USAN LOS CARTONES FILTRANTES

- Los filtros de refinado Cód. CKPV 4 sirven para filtrar el vino tras la terminación. Dichos filtros retienen las partículas más gruesas que se encuentran en suspensión. Por ello no producen un buen acabado del vino.
- Los filtros para el acabado Cód. CKPV 8 se usan para retener las partículas más pequeñas y dar brillo al vino tras el trasiego. Se usan como una segunda filtración.
- Los filtros clarificadores Cód. CKPV 16 dan brillo al vino porque quitan las microimpurezas que se encuentran en suspensión. Use solamente tras haber filtrado el vino por lo menos una vez con los filtros para el acabado.

■ Applications:

This wine filter with built-in BE series pump makes domestic impurity filtering operations very easy with products such as wine, water, etc...

The kit includes a BE 20 M pump (turning in only one direction).

The flow is 360 lt./h with a maximum absorbed power of 30 watts.

■ HOW TO USE THE FILTERING CARDS

- *The CKPV 4 refined cards serve to filter wine following termination. The filter retain the coarser particles found in suspension and therefore do not produce a good wine finish.*
- *The CKPV 8 finish cards are used to retain the smaller particles and give shine to wine following transfer. They are used as a second filtration.*
- *The CKPV 16 clearing filters give wine shine because they remove the micro impurities that are found in suspension. Use only when the wine has been filtered at least once with the filters for finishing.*



DIESEL KIT

Compuesto por:
5 metros de manguera hidrocarburos,
pistola graduación caudal (abrir-cerrar)
filtro aspiración



PISTOLA AUTOMÁTICA

Cierra el paso del líquido
cuando el depósito está lleno.
Caudal máximo: 3.600 lts./h.

■ Aplicaciones:

Electrobomba autoaspirante de anillo líquido, especial para trasiego de gas-oil. Autoaspirante hasta 4 metros, en aspiraciones horizontales de gran longitud es importante instalar una tubería de diámetro superior al de entrada de la bomba.

■ Características constructivas:

Cuerpo y soporte en fundición gris, con tratamiento anticorrosivo incluso en su superficie interna, turbinas en bronce y cierre mecánico resistente al hidrocarburo y eje en acero inoxidable.

■ Motor:

Asíncrono, cerrado y de ventilación externa. Protección termo-amperimétrica incorporada y condensador fijo.

Grado de protección IP-55, según normativa vigente para trasiego de gas-oil.

Aislamiento: clase F.

Temperatura máxima del agua: + 50° C

Temperatura máxima ambiente: + 40° C

■ Applications:

A liquid ring self-driving pump, special for the transfer of diesel fuel. Self-driving up to 4 metres, in long horizontal suction, it is important to install a pipe with a diameter larger than that of the pump inlet.

■ Construction:

Body and support in grey cast iron with rustproof treatment even on the internal surface, impellers in bronze, mechanical seal resistant to hydrocarbons and shaft in stainless steel.

■ Motor:

Sealed asynchronous with external ventilation. Built-in thermo-amperimetric protection and fixed capacitor.

IP-55 protection, according with the regulations for diesel transfer.

Insulation: class F.

Maximum water temperature: + 50° C.

Maximum ambient temperature: + 40° C.

Tipo Type	Cond. µF	r.p.m.	A II 230 V	Potencia		Caudal m ³ /h / Flow m ³ /h							Ø Asp. Imp.
				HP	KW	0	0,3	0,6	1,2	1,8	2,4	2,7	
Altura m.c.a. / Height w.c.m.													
MD-75	16	2.900	4,2	0,8	0,59	51	46	41	32	22	12	6	1"



GPS



GPC

■ Aplicaciones:

Equipos especialmente diseñados para el suministro de gas-oil a calderas de calefacción. En aspiraciones horizontales de gran longitud, instalar tubería de diámetro superior al de la aspiración de la bomba.

Modelo COMPACTO "GPC"

Compuesto por:
Electrobomba MD 75, vaso exp. 5 Lts. hidrocarburos, presostato trabajo y seguridad con rearme manual incorporado, rácór de 5 vías, manómetro, válvula de retención en aspiración, caja con pilotos de señalización, interruptor puesta en marcha, válvula reductora de caudal y bancada general en chapa doblada.

Modelo SIMPLE "GPS"

Compuesto por:
Electrobomba MD 75, vaso exp. 5 Lts. hidrocarburos, presostato de trabajo, rácór 5 vías y manómetro

■ Applications:

Units specially designed for supplying diesel fuel to the burner. In long horizontal suctions, install a pipe with a diameter larger than that of the pump inlet.

GPC COMPACT Model

Comprising:
MD 75 electropump, 5 lts. hydrocarbon expansion tank, working pressure gauge, safety pressure gauge, 5 watt connector, manometer, retention valve in suction, box with warning lights, starting switch, flow reducer valve and general bench in folded plate.

GPS SIMPLE Model

Comprising:
MD 75 electropump, 5 Lts. hydrocarbon expansion tank, working pressure gauge, 5 watt connector and manometer.

Tipo / Type		HP	Voltaje Voltage	"A"	Ø ASP/IMP	Peso Kg.		Caudal l/h.	Presión bar
Simple	Doble					GPG	GPG D		
GPC		0,8	II 230V	4,2	1"	12	-	600	1-5
GPS		0,8	II 230V	4,2	1"	8	-	600	1-5





■ **Aplicaciones:** Bombas magnéticas monobloc desprovistas de sello mecánico, lo que las hace muy adecuada para la elevación de líquidos agresivos tales como: **ácidos débiles, líquidos corrosivos.** Muy utilizadas para aguas saladas, laboratorios, tratamientos de superficies, soluciones de revelado fotográfico, etc.

■ **Características constructivas:** El principio de funcionamiento de las bombas de arrastre magnético es el de que la transmisión se efectúa a través de la atracción de dos imanes concéntricos y compensados, lo que asegura a través del polipropileno un aislamiento total del líquido a bombear con el motor y el exterior. Todas las partes en contacto con el líquido son en polipropileno excepto los casquillos que son de Rulón-Grafito y las tóricas en Vitón. Eje y arandelas en cerámica.

■ **Motor:** Asíncrono y de ventilación externa, a 2.850 r.p.m. protección IP-44, aislamiento clase F.

MAXIMA TEMP. AMBIENTE: 40° C.
MAXIMA TEMP. LIQUIDO BOMBEADO: 80° C.
VISCOSIDAD MAXIMA: 30 CPS.
DENSIDAD MAXIMA: 1,3

NO DEBE TRABAJAR EN SECO Y NO RECOMENDABLE PARA LIQUIDOS CON PARTICULAS EN SUSPENSION

■ **Applications:** Single block magnetic pumps without a mechanical seal, which makes them highly suitable for raising aggressive liquids such as: weak acids, corrosive liquids. Used widely for salt waters, laboratories, surface treatments, photographic developing solutions, etc.

■ **Construction:** The working principle of the magnetic drag pumps is that the transmission is developed by the attraction of two concentric, compensated magnets, which, through polypropylene, ensures full insulation of the liquid to be pumped from the motor and the exterior. All parts in contact with the liquid are in polypropylene, excepts for the bushings, which are in Rulon-Graphite and Viton o-rings. Shaft and washers in ceramic.

■ **Motor:** Asynchronous with external ventilation at 2,850 rpm, IP-44 protection, class F insulation.

MAX. AMBIENT TEMPERATURE: 40° C
MAX. TEMP. PUMPED LIQUID: 80° C
MAXIMUM VISCOSITY: 30 CPS
MAXIMUM DENSITY: 1.3

NOT FOR DRY WORKING AND NOT RECOMMENDABLE FOR LIQUIDS WITH SUSPENDED PARTICLES

Tipo Type	Voltaje Voltage	Watt.	Altura m.c.a. / Height w.c.m.				Ø	
			0	2	4	5	ASP.	IMP.
			Caudal m³/h / Flow m³/h					
HCM 75	II 230	100	3,9	3,2	2,1	1,2	3/4"	3/4"
HCM 100	II 230	150	5,1	4,2	3	2,2	1"	1"

Bombas de Vaciado de Bidones

Serie "EL"



■ **Aplicaciones:** Bomba ideal para el vaciado de bidones de 200 lts. u otros que contengan líquidos de una variadísima gama de ácidos o bases. Incorpora caña de 900 mm. (bajo demanda 1.200 mm.).

■ **Características constructivas:** La novedad más destacable de esta bomba consiste en que en el tubo se ha dispuesto un husillo-espiral (tornillo de Arquímedes) que hace llegar el fluido hasta el impulsor situado en la parte superior de la caña. Materiales de construcción íntegramente en PPV (PP con fibra).

■ **Motor:** A 2.850 r.p.m., 50 Hz, monofásico 230 V
MAXIMA TEMP. LIQUIDO BOMBEADO: 50° C.
VISCOSIDAD MAXIMA: 300 CPS.
DENSIDAD MAXIMA: 1,6

NO DEBE TRABAJAR EN SECO MAS DE 2 MIN. Y NO RECOMENDABLE PARA LIQUIDOS CON PARTICULAS EN SUSPENSION.

■ **Applications:** An ideal pump for emptying 200 litre drums or others containing liquids of a broad range of acids or bases.

■ **Construction:** The most important novelty of this pump is that the pipe has been provided with a spindle-spiral (in Archimedes form) to make the liquid flow to the drive on the upper part of the cane. Entire PPV (PP with fibre) construction.

■ **Motor:** 2,850 rpm, 50 Hz. Single phase 230 V.
MAX. TEMP. PUMPED LIQUID: 50° C
MAXIMUM VISCOSITY: 300 CPS
MAXIMUM DENSITY: 1.6

DRY WORKING SHOULD NOT BE UNDERTAKEN FOR MORE THAN 2 MIN., AND NOT RECOMMENDABLE FOR LIQUIDS WITH SUSPENDED PARTICLES.

Tipo	Voltaje	Watt.	Caudal máx. / Max. Flow	Altura máx. / Max. Height	Peso / Weight
EL 450	II 230	300	5,6 m³/h	7 m.c.a.	6 Kg.

Tabla Selección Rápida "ROTOR HÚMEDO"	124
--	-----

Tabla Selección Rápida "ROTOR SECO"	126
--	-----

ROTOR HÚMEDO

Serie Circuladoras Domésticas "VA"	130
---------------------------------------	-----

Serie Pequeñas Instalaciones Colectivas "A-B-D"	132
--	-----

Circuladoras Calefacción-Refrigeración "BMH-BPH-DMH-DPH"	134
---	-----

Serie Agua Sanitaria "VS"	138
---------------------------	-----

ROTOR SECO

Serie "ALM-ALP"	139
-----------------	-----

Serie "KLM-KLP-DKLM-DKLP"	140
---------------------------	-----

Serie "CM"	142
------------	-----

Serie "CP"	145
------------	-----



MODELO		MODELO		P1 MAX. W	Q m³/h l/min	0	0,6	1,2	1,8		
MONOFASICA SIMPLE	TRIFASICA SIMPLE	MONOFASICA GEMELA	TRIFASICA GEMELA			0	10	20	30		
VA 35/130	-	-	-	71		4,3	3,9	3,4	2,8		
VA 35/180											
VA 55/130	-	-	-	82		5,4	4,7	4,5	3,3		
VA 55/180											
VA 55/180 X											
VA 65/130	-	-	-	102		6,3	5,8	5,3	4,3		
VA 65/180											
VA 65/180 X											
VS 8/150	-	-	-	40	H (m)	0,83	0,75	0,52	0,22		
VS 16/150	-	-	-	54		1,82	1,75	1,65	1,44		
VS 35/150	-	-	-	71		4,1	3,7	3,3	2,82		
VS 65/150	-	-	-	103		6	5,55	5,05	4,25		
A 50/180 XM	-	D 50/250.40 M	-	116		5,8	5,7	5,6	5,35		
B 50/250.40 M											
A 56/180 XM	-	D 56/250.40 M	-	140		5,83	5,8	5,75	5,7		
B 56/250.40 M											
A 80/180 XM	-	D 80/250.40 M	-	169		8	7,8	7,6	7,3		
B 80/250.40 M											
A 110/180 XM	-	D 110/250.40 M	-	246	11,2	11	10,8	10			
B 110/250.40 M											
-	A 50/180 XT B 50/250.40 T	-	D 50/250.40 T	113	5,7	5,6	5,5	5,4			
-	A 56/180 XT B 56/250.40 T	-	D 56/250.40 T	121	5,9	5,85	5,8	5,75			
-	A 80/180 XT B 80/250.40 T	-	D 80/250.40 T	161	7,8	7,7	7,4	7,1			
-	A 110/180 XT B 110/250.40 T	-	D 110/250.40 T	-	11,2	11	10,8	10			
BPH 65/250.40 M	-	DPH 65/250.40 M	-	316	7,2			6,8			
BPH 120/250.40 M	-	DPH 120/250.40 M	-	510	11			10,3			
BPH 60/280.50 M	-	DPH 60/280.50 M	-	595	7,65			7,5			
BPH 60/340.65 M	-	DPH 60/340.65 M	-	735	6,8			6,79			
-	BMH 30/250.40 T	-	DMH 30/250.40 T	192	3,3			3,1			
-	BPH 60/250.40 T	-	DPH 60/250.40 T	348	7,65			7,4			
-	BPH 120/250.40 T	-	DPH 120/250.40 T	536	12						
-	BMH 30/280.50 T	-	DMH 30/280.50 T	255	3,15						
-	BMH 60/280.50 T	-	DMH 60/280.50 T	410	5,83						
-	BPH 60/280.50 T	-	DPH 60/280.50 T	589	7,95						
-	BPH 120/280.50 T	-	DPH 120/280.50 T	870	11,7						
-	BPH 150/280.50 T	-	DPH 150/280.50 T	1130	15						
-	BPH 180/280.50 T	-	DPH 180/280.50 T	1630	18,4						
-	BMH 30/340.65 T	-	DMH 30/340.65 T	270	3,15						
-	BMH 60/340.65 T	-	DMH 60/340.65 T	445	5,4						
-	BPH 60/340.65 T	-	DPH 60/340.65 T	756	7,4						
-	BPH 120/340.65 T	-	DPH 120/340.65 T	1275	10,9						
-	BPH 150/340.65 T	-	DPH 150/340.65 T	2800	14,9						
-	BPH 180/340.65 T	-	DPH 180/340.65 T	1760	17,9						
-	BMH 30/360.80 T	-	DMH 30/360.80 T	484	3,9						
-	BMH 60/360.80 T	-	DMH 60/360.80 T	763	5,7						
-	BPH 120/360.80 T	-	DPH 120/360.80 T	1820	11,8						
-	BPH 150/360.80 T	-	DPH 150/360.80 T	2710	15,3						
-	BPH 180/360.80 T	-	DPH 180/360.80 T	2310	17,5						

	2,4	3	4,2	5,4	7,2	9,6	12	14,4	18	21	24	27	30	33	36	42	54	60	72	
	40	50	70	90	120	160	200	240	300	350	400	450	500	550	600	700	900	1000	1200	
	2,15	1,4																		
	2,6	1,75	0,85																	
	3,4	2,4																		
	1,07	0,6																		
	2,2	1,6	1,05																	
	3,4	2,6	1,8	1,05																
	5,15	4,8	4,05	3,2	1,55	2,6	0,85													
	5,65	5,55	5,25	4,85	4															
	7	6,6	5,8	4,8	3,1	4,5	1,7													
	9,9	9,8	9	8,2	6,8															
	5,2	4,9	4,3	3,6																
	5,7	5,6	5,3	4,9	4															
	6,8	6,6	5,8	4,9	3															
	9,9	9,8	9	8,2	6,8	4,5	1,7													
	6,7	6,5	6,2	5,8	5	3,7	2													
	10,1	9,8	9,2	8,6	7,65	6,2	4,35	2,4												
	7,45	7,4	7,3	7,2	6,98	6,7	6,2	5,75	4,6	3,45	2,3									
	6,75	6,7	6,6	6,57	6,5	6,35	6,2	5,95	5,5	4,93	4,35	3,6	2,85	2,03	1,2					
	2,95	2,85	2,5	2,1	1,15															
	7,3	7,2	6,8	6,4	5,45	3,9	2,25													
	11	10,7	10,1	9,5	8,4	6,8	4,7	2,2												
	3,02	3	2,93	2,85	2,65	2,3	1,75	1,2												
	5,65	5,6	5,49	5,35	5,1	4,75	4,2	3,65	2,62											
	7,75	7,7	7,6	7,5	7,35	6,92	6,45	5,85	4,65	3,53	2,4									
			11,3	11	10,75	10,25	9,6	8,9	7,75	6,58	5,4	4	2,6							
			14,6	14,4	14	13,6	12,7	11,8	10,5	9	7,5									
					17,4	17	16,4	15,6	14,4	13,2	12	10,4	8,8	7	5,2					
			3,09	3,02	2,98	2,85	2,55	2,25	1,65											
			5,15	5,05	4,9	4,7	4,45	4,1	3,45	2,85	2,25									
			7,35	7,3	7,24	7,1	6,9	6,65	6,15	5,53	4,9	4,1	3,3	2,35	1,4					
			10,75	10,68	10,6	10,5	10,38	10,2	9,8	9,25	8,7	7,93	7,15	6,18	5,2	3				
			14,88	14,83	14,75	14,65	14,55	14,3	13,88	13,27	12,65	11,83	11	10,18	9,35	7,15				
					17,8	17,7	17,5	17,3	16,8	16,25	15,7	14,9	14,1	13,1	12,1	10				
					3,85	3,8	3,75	3,65	3,48	3,29	3,1	2,78	2,45	2,1	1,75					
					5,66	5,61	5,59	5,5	5,4	5,2	5	4,78	4,55	4,23	3,9	3,1				
					11,65	11,58	11,5	11,4	11,25	11	10,75	10,48	10,2	9,80	9,39	8,37	5,65			
					15,1	15,06	14,99	14,92	14,75	14,63	14,5	14,25	14	13,7	13,4	12,4	10,3	8,15	6	
					17,4	17,25	17,1	16,8	16,25	15,63	15	14,35	13,7	12,85	12	10,1	5,5			

MODELO		MODELO		P2 NOMINAL		Q m³/h l/min	H				
MONOFASICA SIMPLE	TRIFASICA SIMPLE	MONOFASICA GEMELA	TRIFASICA GEMELA	HP	KW		0	3,6	4,8	6	12
						0	60	80	100	200	
-	CP 40/1900T	-	-	1	0,8	176	176	174	17	14	
-	CP 40/2300T	-	-	1,5	1,1	21,8	21,8	21,3	21	18	
-	CP 40/2700T	-	-	2	1,5	26,9	26,9	26,7	26,2	23,2	
-	CP 40/3500T	-	-	3	2,2	34,8	34,9	34,7	34,2	31,7	
-	CP 40/3800T	-	-	4	3				38	35	
-	CP 40/4700T	-	-	5,5	4				47	44	
-	CP 40/5500T	-	-	7,5	5,5				55	53	
-	CP 40/6200T	-	-	10	7,5				62	59	
-	CP 50/2200T	-	-	1,5	1,1				20	16,5	
-	CP 50/2600T	-	-	2	1,5				25	22	
-	CP 50/3100T	-	-	3	2,2				31	28,5	
-	CP 50/4100T	-	-	5,5	4				40,7	38,5	
-	CP 50/4600T	-	-	7,5	5,5						
-	CP 50/5100T	-	-	10	7,5						
-	CP 50/5650T	-	-	10	7,5						
-	CP 65/1470T	-	-	2	1,5	14,7			14,5	14,3	
-	CP 65/1900T	-	-	3	2,2	19			18,7	18,4	
-	CP 65/2280T	-	-	4	3	22,8			22,5	22,3	
-	CP 65/2640T	-	-	5,5	4	26,4			26,2	26	
-	CP 65/3400T	-	-	7,5	5,5	34					
-	CP 65/4100T	-	-	10	7,5	41					
-	CP 65/4700T	-	-	15	11	47					
-	CP 65/5500T	-	-	20	15	55					
-	CP 65/6150T	-	-	25	18,5	61,5					
-	CP 65/6750T	-	-	30	22	67,5					
-	CP 65/7350T	-	-	30	22	73,5					
-	CP 65/9250T	-	-	40	30	92,5					
-	CP 80/1400T	-	-	3	2,2	14					
-	CP 80/1700T	-	-	4	3	17					
-	CP 80/2050T	-	-	5,5	4	20,5					
-	CP 80/2400T	-	-	7,5	5,5	24					
-	CP 80/2770T	-	-	10	7,5	27,7					
-	CP 80/3250T	-	-	15	11	32,5					
-	CP 80/4000T	-	-	20	15	40					
-	CP 80/5150T	-	-	25	18,5	51,5					
-	CP 80/5650T	-	-	30	22	56,5					
-	CP 80/6850T	-	-	40	30	68,5					
-	CP 80/8600T	-	-	50	37	86					
-	CP 80/9600T	-	-	60	45	96					
-	CP 80/10200T	-	-	75	55	102					
-	CP 100/1600T	-	-	5,5	4	16					
-	CP 100/1950T	-	-	7,5	5,5	19,5					
-	CP 100/2350T	-	-	10	7,5	23,5					
-	CP 100/2400T	-	-	15	11	24					
-	CP 100/3050T	-	-	20	15	30,5					
-	CP 100/3550T	-	-	25	18,5	35,5					
-	CP 100/3850T	-	-	30	22	38,5					
-	CP 100/4800T	-	-	40	30	48					
-	CP 100/5600T	-	-	50	37	56					
-	CP 100/6300T	-	-	60	45	63					
-	CP 100/8300T	-	-	75	55	83					
-	CP 125/4750T	-	-	50	37	46,5					
-	CP 125/5300T	-	-	60	45	51,5					
-	CP 125/5800T	-	-	75	55	57,5					



■ Aplicaciones:

Bomba para circulación de agua caliente en instalaciones domésticas de calefacción centralizadas, de tipo cerrado y presurizadas o a vaso abierto. Idóneas también para instalaciones de energía solar.

■ Características Constructivas:

Cuerpo bomba en fundición, carcasa motor en aluminio, turbina en tecnopolímero, eje rotor, camisa protección del rotor en acero inoxidable, anillo en cerámica y anillo cierre en etileno propileno.

■ Motor:

Motor a dos polos de tipo asíncrono de rotor húmedo, sin sello mecánico, proyectado para trabajar a 3 velocidades. Rotor montado sobre cojinetes en grafito.

Campo de prestaciones:

de 0,5 a 4 m³/h con alturas hasta 6,3 metros.

Campo de temperatura del líquido: de +2° C a + 110° C

Líquido bombeado:

limpio, libre de sustancias sólidas, no viscoso, químicamente neutro, cercano a las características del agua.

Mínima presión de aspiración requerida:

- 1,5 metros para VA 35/55.
- 2,5 metros para VA 65.

Grado de protección del motor: IP-44.

Aislamiento: clase F.

■ Applications:

Pump for circulating hot water in closed and pressurised or open tank centralised home heating and air conditioning systems.

Also suitable for solar power systems.

■ Construction characteristics:

cast iron hydraulic unit and wet rotor motor Die-cast aluminium motor casing. Technopolymer impeller.

No overload protection required.

Protection level: IP 44, Insulating class: F, Cable grommet: PG 11

Standard voltage: single-phase 230 V / 50 Hz

■ Operating range:

From 0.5 to 4 m³/h with head up to 6.3 metres.

Liquid temperature range: from -10°C to +110°C.

To prevent condensation from forming inside the motor, the pumped liquid temperature must always be over the room temperature.

Characteristics of pumped liquid: clean, free from solids and mineral oils, non viscous, chemically neutral, close to the characteristics of water (max. glycol 30%).

VA 35/130-180

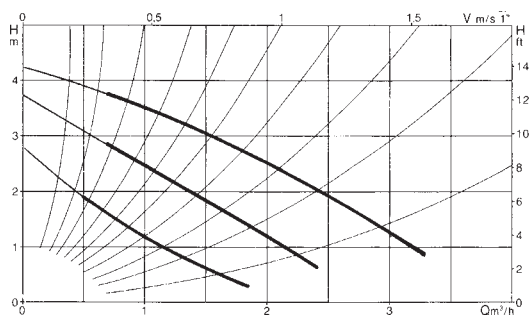

VA 55/130-180

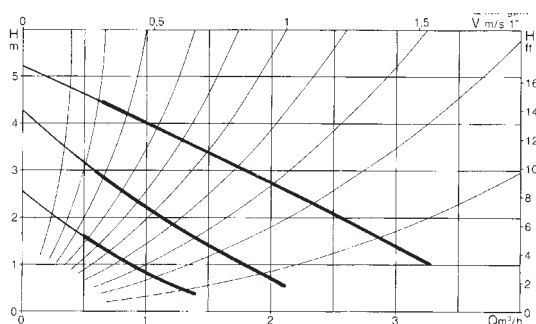

VA 65/130-180

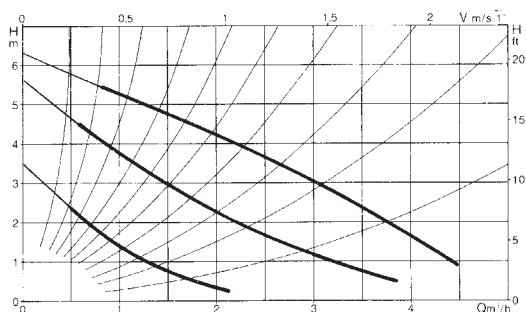

CIRCULADORAS DOMÉSTICAS

Tipo Type	Alimentación 50 HZ	Rácores	Datos Eléctricos					Entre Ejes mm.	Peso Kg.
			Vel.	r.p.m. 1/min.	P1 máx. W	Cons. A	Cons. µF		
VA 35/130	1 x 230 V	1"	1	1.440	44	0,2	2	130	2,65
VA 35/180	1 x 230 V	1"	2	1.910	60	0,28		180	2,8
			3	2.370	71	0,31			
VA 55/130	1 x 230 V	1"	1	1.330	45	0,2	2,5	130	2,65
VA 55/180	1 x 230 V	1"	2	1.815	64	0,29		180	2,8
VA 55/180 X	1 x 230 V	1 1/4"	3	2.330	82	0,36		180	2,9
VA 65/130	1 x 230 V	1"	1	1.050	51	0,24	2,5	130	2,65
VA 65/180	1 x 230 V	1"	2	1.460	78	0,35		180	3,15
VA 65/180 X	1 x 230 V	1 1/4"	3	2.100	102	0,45		180	3,15



Aplicaciones: Bomba para circulación de agua caliente en instalaciones domésticas de calefacción centralizadas, de tipo cerrado y presurizadas o a vaso abierto. Idóneas también para instalaciones de energía solar.

Características: Cuerpo bomba en fundición, carcasa motor en aluminio. Turbina en Tecnopolímero, eje rotor, camisa de protección del rotor y disco cierre en acero inoxidable.

Anillo en cerámica y anillo sello en etileno-propileno. Motor a 2 polos, asíncrono de rotor húmedo sin sello mecánico, a tres velocidades. Rotor montado sobre cojinetes en grafito.

Campo de prestaciones: de 1 a 14 m³/h. hasta 11 m.c.a.

Campo de temperatura del líquido: +2° C a +110° C.

Líquido bombeado: Limpio, libre de sustancias sólidas, no viscoso, no cristalizado y neutro.

Máxima presión del ejercicio: 10 bar (1000 Kpa).

Mínima presión de aspiración: Valores a Q max. y Temp. de líquido a + 90° C: 1,5 mts. para A50 - B50 - D50, A56 - B56 - D56

2,5 mts. para A80 - B80 - D80, A110 - B110 - D110

Grados de protección: IP-41, IP-44 (trifase)

Clase de aislamiento: F



Applications:

Pump for circulating hot water in small closed and pressurised or open tank civil and industrial community heating and air-conditioning systems.

Construction characteristics:

Single body comprising cast iron hydraulic unit and wet rotor motor Die-cast aluminium motor casing.

Technopolymer impeller. Tempered stainless steel driving shaft mounted on graphite bearings lubricated by the pumped liquid. Stainless steel protective rotor sleeve, stator sleeve and closing flange. Ceramic thrust bearing, E.P.D.M. O-rings and brass air outlet cap.

For the three-phase version the motor must be connected to the power supply through an external contactor.

Protection level: IP 44. Insulating class: F

Tipo Type	Alimentación 50 HZ	Rácores	Datos Eléctricos					Entre Ejes mm.	Peso Kg.
			Velocidad	r.p.m. 1/min.	P1 máx W	Cons. A	Cond. µF		
A 50/180 XM	1 x 230 V	1 1/4" F	1	2.297	168	0,80	4	180	4,8
			2	2.651	189	0,92			
			3	2.791	184	0,92			
A 50/180 XT	3 x 400 V	1 1/4" F	1	2.520	129	0,23	-	180	5
			2	2.838	201	0,50			
A 56/180 XM	1 x 230 V	1 1/4" F	1	1.394	224	1	7	180	4,8
			2	2.117	294	1,32			
			3	2.658	271	1,18			
A 56/180 XT	3 x 400 V	1 1/4" F	1	2.178	200	0,32	-	180	5
			2	2.708	291	0,60			
A 80/180 XM	1 x 230 V	1 1/4" F	1	1.688	218	1	7	180	4,8
			2	2.374	260	1,17			
			3	2.683	256	1,12			
A 80/180 XT	3 x 400 V	1 1/4" F	1	2.227	186	0,30	-	180	5
			2	2.727	272	0,57			
A 110/180 XM	1 x 230 V	1 1/4" F	1	2.052	361	1,64	12	180	7,5
			2	2.552	393	1,78			
			3	2.746	410	1,77			
A 110/180 XT	3 x 400 V	1 1/4" F	1	2.341	289	0,48	-	180	7,7
			2	2.759	403	0,90			
B 50/250.40 M D 50/250.40 M	1 x 230 V	DN 40 - PN10	1	2.215	180	0,85	2,5	250	8,6
			2	2.616	194	0,95			
			3	2.766	195	0,95			
B 50/250.40 T D 50/250.40 T	3 x 400 V	DN 40 - PN10	1	2.502	139	0,25	-	250	8,8
			2	2.827	197	0,52			
B 56/250.40 M D 56/250.40 M	1 x 230 V	DN 40 - PN10	1	1.485	228	1,06	7	250	8,6
			2	2.226	287	1,30			
			3	2.636	282	1,23			
B 56/250.40 T D 56/250.40 T	3 x 400 V	DN 40 - PN10	1	2.178	200	0,33	-	250	8,8
			2	2.704	297	0,60			
B 80/250.40 M D 80/250.40 M	1 x 230 V	DN 40 - PN10	1	1.615	223	1	7	250	8,6
			2	2.356	262	1,20			
			3	2.674	264	1,15			
B 80/250.40 T D 80/250.40 T	3 x 400 V	DN 40 - PN10	1	2.226	187	0,31	-	250	8,8
			2	2.724	271	0,57			
B 110/250.40 M D 110/250.40 M	1 x 230 V	DN 40 - PN10	1	2.052	361	1,64	12	250	9,4
			2	2.552	393	1,78			
			3	2.746	410	1,77			
B 110/250.40 T D 110/250.40 T	3 x 400 V	DN 40 - PN10	1	2.341	289	0,48	-	250	9,6
			2	2.759	403	0,90			

A 50/180 XM - B 50/250.40 M - D50/250.40 M

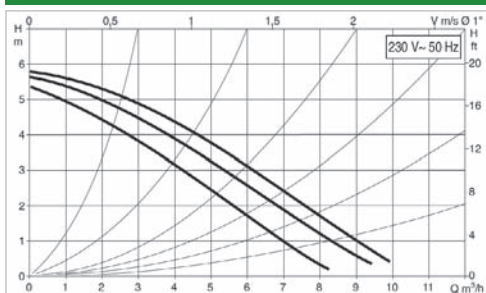

A 50/180 XT - B 50/250.40 T - D50/250.40 T



A 56/180 XM - B 56/250.40 M - D56/250.40 M



A 56/180 XT - B 56/250.40 T - D56/250.40 T

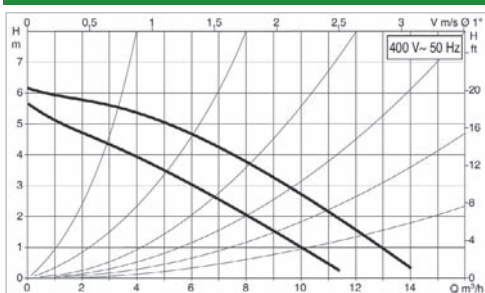

A 80/180 XM - B 80/250.40 M - D80/250.40 M

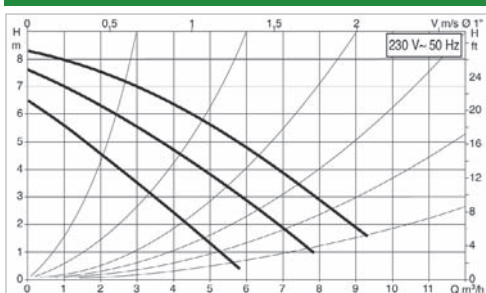

A 80/180 XT - B 80/250.40 T - D80/250.40 T

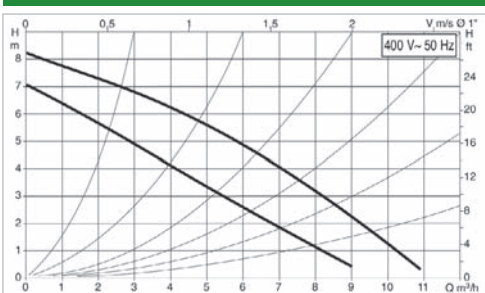

A 110/180 XM - B 110/250.40 M - D110/250.40 M

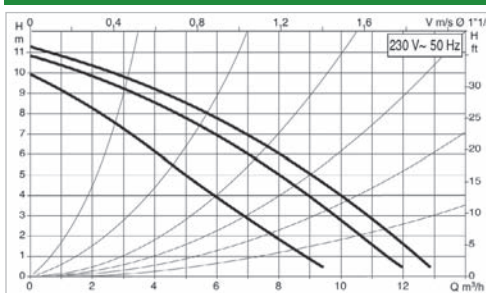

A 110/180 XT - B 110/250.40 T - D110/250.40 T

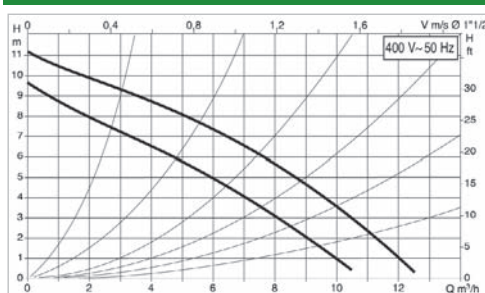

Para ver los rendimientos hidráulicos de las bombas trifásicas a 230 V consulten Catálogo Técnico Circuladoras
To see hydraulic performance of the three phase 230 V pumps check the Circulating pump Technical Catalogue

■ Aplicaciones:

Bomba para circulación de agua en instalaciones colectivas de calefacción y refrigeración para usos civiles e industriales. Todos los modelos están disponibles en versión simple y gemela.

■ Características Constructivas:

Cuerpo único formado por la parte hidráulica en fundición de hierro y motor a rotor húmedo.

Carcasa motor en fundición de hierro. Bocas de aspiración e impulsión embridadas y provistas de un orificio roscado para manómetro de control. Turbina en tecnopolímero, eje motor en acero inoxidable templado montado sobre cojinete en grafito lubricado por el mismo líquido bombeado. Camisa de protección del rotor y camisa estator en acero inoxidable. Anillo cierre en cerámica, anillo goma en etileno propileno y tapón de vaciado de aire en latón. Motor de tipo asíncrono a cuatro polos para las versiones BMH y DMH, a dos polos para las versiones BPH y DPH. Los circuladores monofásicos han sido proyectados para trabajar a tres velocidades a 230 V, mientras que los circuladores trifásicos han sido proyectados para funcionar a dos velocidades a 230 V trif. y a tres velocidades a 400 V. La velocidad de funcionamiento viene regulada a través de un selector especial colocado en la caja de bornes con el fin de adaptar el funcionamiento del circulador a las características de la instalación.

■ Campo de prestaciones:

de 1,5 a 78 m³/h con alturas hasta 15 metros.

■ Campo de temperatura del líquido:

de -10° C a + 120° C

Para Monofásicas y BPH 150 de -10° C a +110° C



■ Applications:

Pump for circulating water in civil and industrial community heating and air-conditioning systems. All models are available in both the single and twin versions.

■ Construction characteristics:

Single body comprising cast iron hydraulic unit and wet rotor motor. Aluminium motor casing. Technopolymer impeller. Tempered stainless steel driving shaft mounted on graphite bearings lubricated by the pumped liquid. Stainless steel protective rotor sleeve and stator sleeve. Ceramic thrust bearing, E.P.D.M. Orings and brass air outlet cap.

Circulator protection level: IP 44 both single-phase and three-phase.

Insulating class: H - Cable.

Standard voltage: single-phase 230V/50Hz

three-phase 230V-400V/50Hz

This product complies with EN 60335-2-51 European standard

Tipo Type	Aliment. 50 HZ	Bridas	Entre Ejes mm.
BMH 30/250.40T DMH 30/250.40T	3 x 230 V 3 x 400 V	DN 40	250
BPH 60/250.40 M DPH 60/250.40 M	1 x 230 V	DN 40	250
BPH 60/250.40 T DPH 60/250.40 T	3 x 230 V 3 x 400 V	DN 40	250
BPH 120/250.40 M DPH 120/250.40 M	1 x 230 V	DN 40	250
BPH 120/250.40 T DPH 120/250.40 T	3 x 230 V 3 x 400 V	DN 40	250
BMH 30/280.50T DMH 30/280.50T	3 x 230 V 3 x 400 V	DN 50	280
BMH 60/280.50T DMH 60/280.50T	3 x 230 V 3 x 400 V	DN 50	280
BPH 60/280.50 M DPH 60/280.50 M	1 x 230 V	DN 50	280
BPH 60/280.50.T DPH 60/280.50.T	3 x 230 V 3 x 400 V	DN 50	280
BPH 120/280.50 T DPH 120/280.50 T	3 x 230 V 3 x 400 V	DN 50	280
BPH 150/280.50.T DPH 150/280.50.T	3 x 230 V 3 x 400 V	DN 50	280
BPH 180/280.50T DPH 180/280.50T	3 x 230 V 3 x 400 V	DN 50	280

Tipo Type	Aliment. 50 HZ	Bridas	Entre Ejes mm.
BMH 30/340.65 T DMH 30/340.65 T	3 x 230 V 3 x 400 V	DN 65	340
BMH 60/340.65 T DMH 60/340.65 T	3 x 230 V 3 x 400 V	DN 65	340
BPH 60/340.65 M DPH 60/340.65 M	1 x 230 V	DN 65	340
BPH 60/340.65 T DPH 60/340.65 T	3 x 230 V 3 x 400 V	DN 65	340
BPH 120/340.65 T DPH 120/340.65 T	3 x 230 V 3 x 400 V	DN 65	340
BPH 150/340.65 T DPH 150/340.65 T	3 x 230 V 3 x 400 V	DN 65	340
BPH 180/340.65 T DPH 180/340.65 T	3 x 230 V 3 x 400 V	DN 65	340
BMH 30/360.80 T DMH 30/360.80 T	3 x 230 V 3 x 400 V	DN 80	360
BMH 60/360.80.T DMH 60/360.80.T	3 x 230 V 3 x 400 V	DN 80	360
BPH 120/360.80 T DPH 120/360.80 T	3 x 230 V 3 x 400 V	DN 80	360
BPH 150/360.80 T DPH 150/360.80 T	3 x 230 V 3 x 400 V	DN 80	360
BPH 180/360.80T DPH 180/360.80T	3 x 230 V 3 x 400 V	DN 80	360

Circuladoras Calefacción-Refrigeración
Serie "BMH-BPH-DMH-DPH"

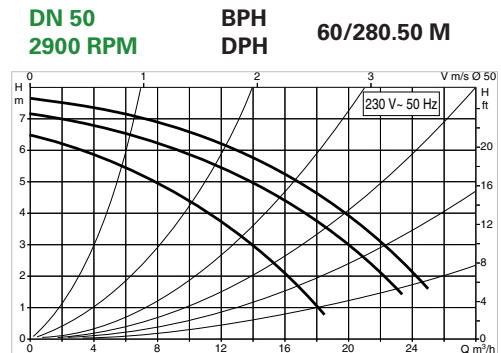
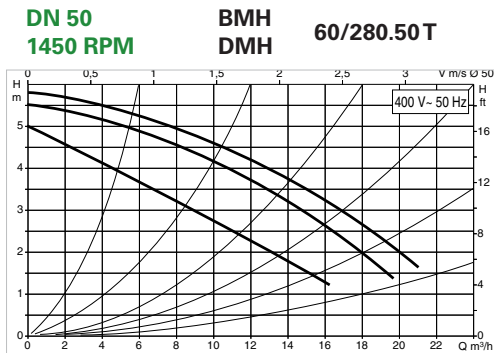
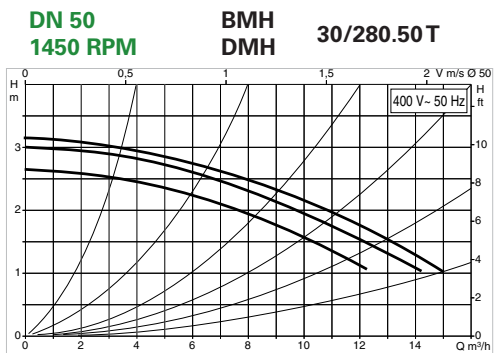
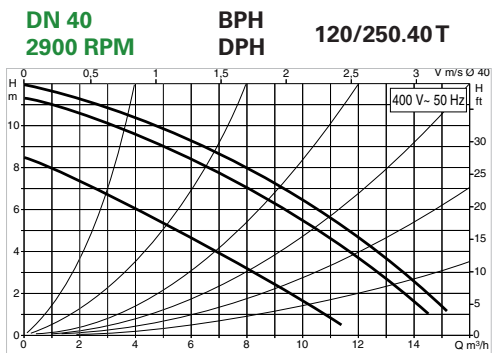
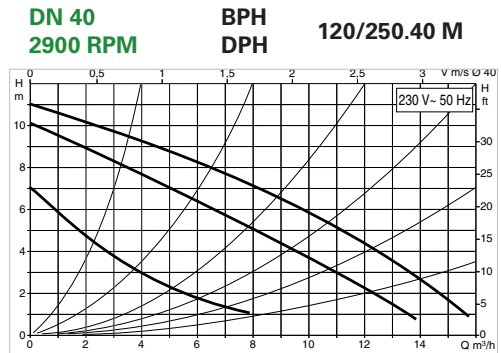
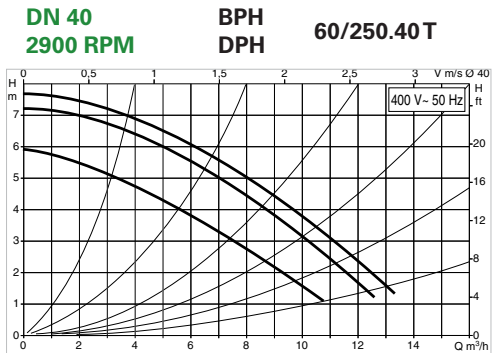
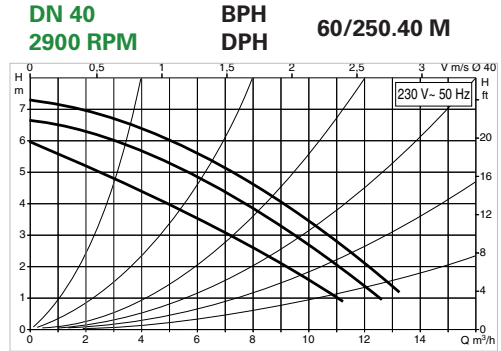
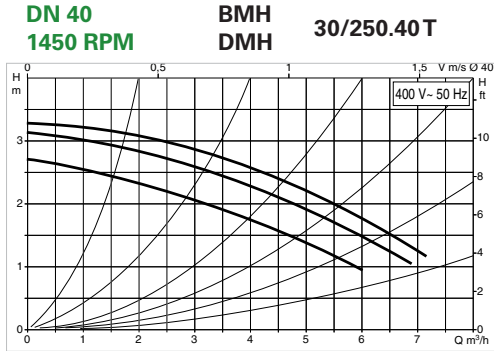

Para ver los rendimientos hidráulicos de las bombas trifásicas a 230 V consulten Catálogo Técnico Circuladoras
To see hydraulic performance of the three phase 230 V pumps check the Circulating pump Technical Catalogue



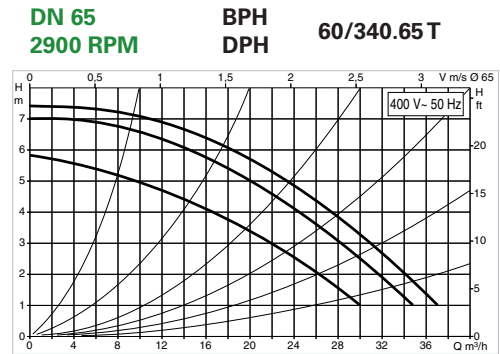
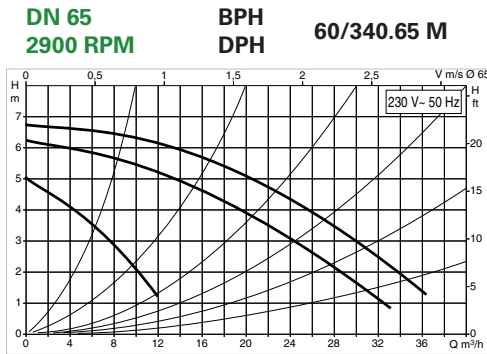
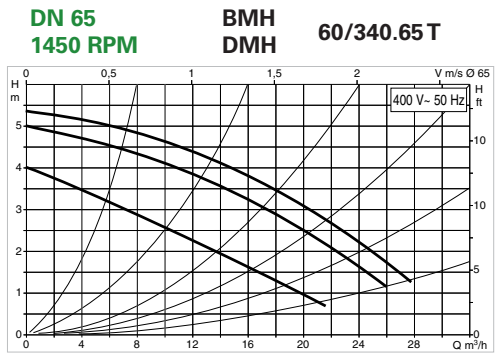
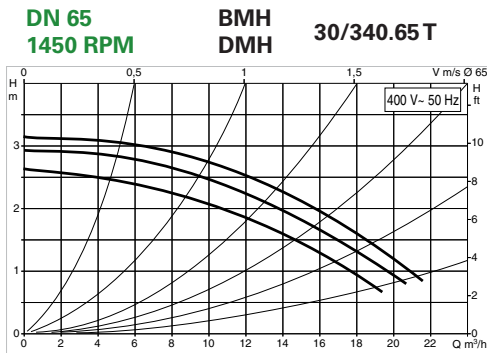
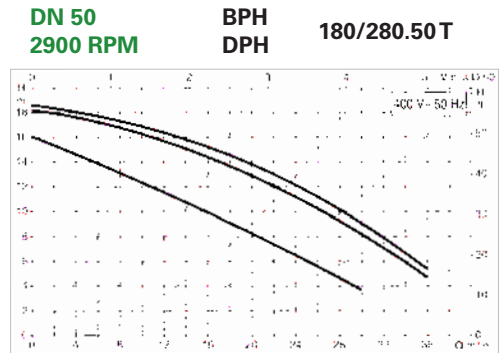
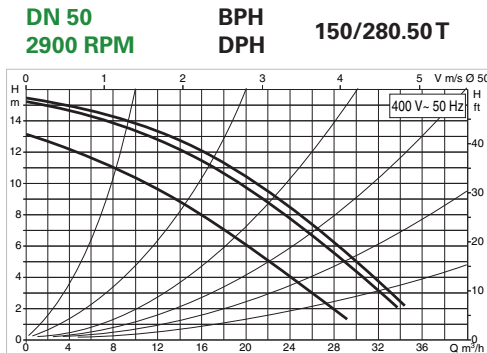
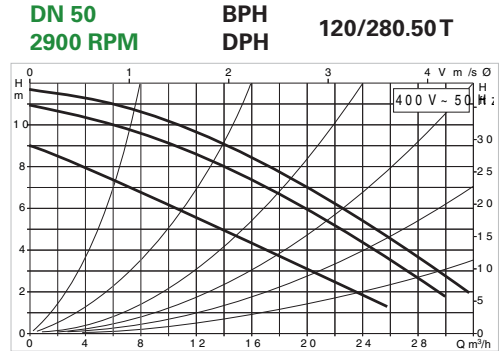
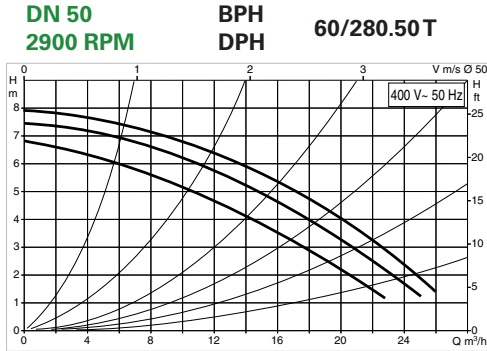

Para ver los rendimientos hidráulicos de las bombas trifásicas a 230 V consulten Catálogo Técnico Circuladoras
To see hydraulic performance of the three phase 230 V pumps check the Circulating pump Technical Catalogue

Circuladoras Calefacción-Refrigeración
Serie "BMH-BPH-DMH-DPH"

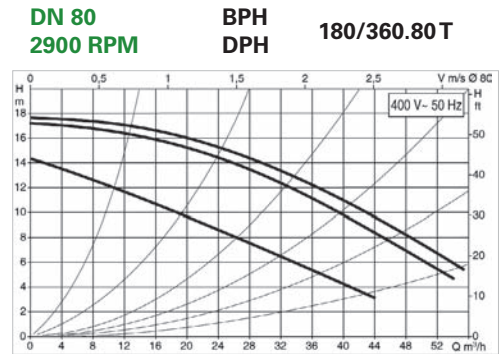
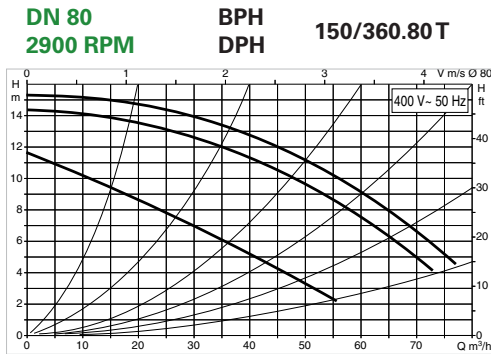
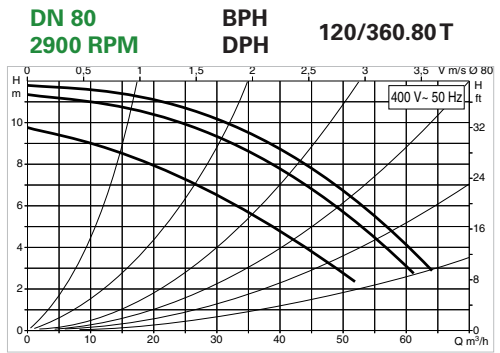
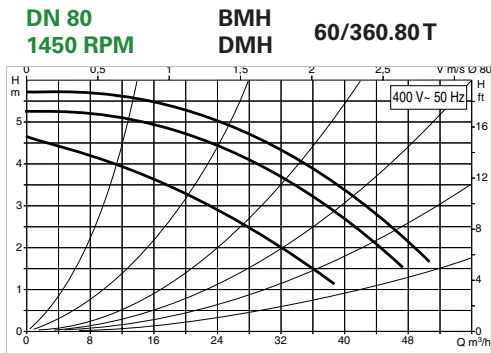
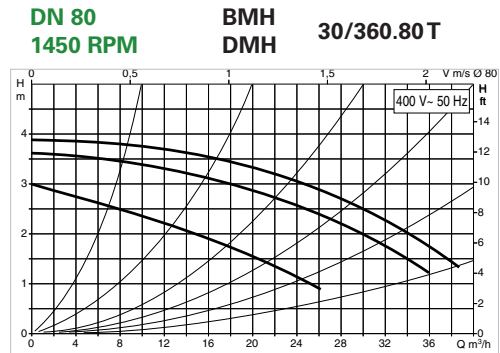
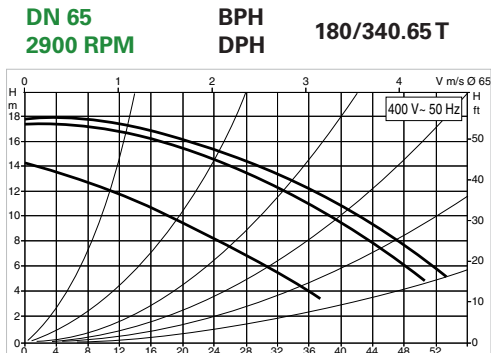
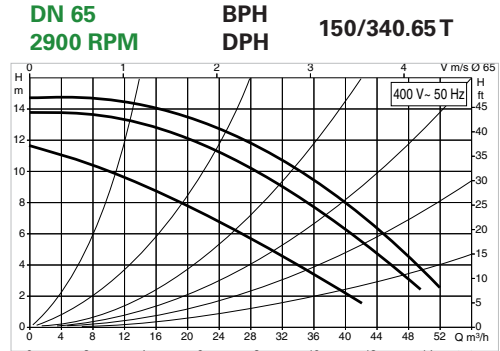
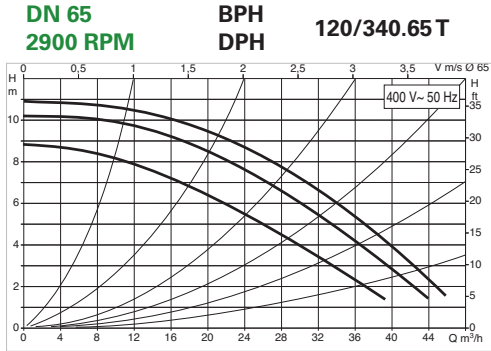

Para ver los rendimientos hidráulicos de las bombas trifásicas a 230 V consulten Catálogo Técnico Circuladoras
 To see hydraulic performance of the three phase 230 V pumps check the Circulating pump Technical Catalogue





■ Aplicaciones:

Bomba de circulación para instalaciones de agua caliente sanitaria de tipo cerrado o a vaso abierto.

■ Características Constructivas:

Cuerpo Bomba en bronce, carcasa motor en aluminio, turbina en tecnopolímero, eje rotor, camisa de protección del rotor y disco cierre en acero inoxidable.

Anillo en cerámica y anillo sello en etilenopropileno.

Motor, asíncrono de rotor húmedo sin sello mecánico.

Rotor montado sobre cojinetes en grafito.

Campo de prestaciones: de 0,5 a 5m³/h hasta 6,5 m.c.a.

Campo de temperatura del líquido: +2° C a +110° C.

Líquido bombeado:

Limpio, libre de sustancias sólidas, no viscoso, no cristalizado y neutro.

Máxima presión de ejercicio: 10 bar (1000K Pa).

Mínima presión de ejercicio:

valores a Q máx. y temp. del líquido a +90° C: 2,5 mts.

Grado de protección: IP-41

Clase de aislamiento: F.

■ Applications:

Pump for circulating hot domestic water in closed and pressurised or open tank systems.

Also suitable for solar power systems.

■ Construction characteristics:

Single body comprising bronze hydraulic unit and wet rotor motor. Die-cast aluminium motor casing. Technopolymer impeller. Ceramic driving shaft mounted on graphite bearings lubricated by the pumped liquid. Stainless steel protective rotor sleeve, stator sleeve and closing flange. Ceramic thrust bearing, E.P.D.M. O-rings and brass air outlet cap.

Two or four pole asynchronous motor with squirrel cage rotor. Motor self-protected against resistance. No overload protection required.

Protection level: IP 44. Insulating class: F

Rated voltage: single-phase 230 V / 50 Hz

Tipo Type	Alimentación 50 HZ	Rácores	Datos Eléctricos				Entre Ejes mm.	Peso Kg.
			r.p.m. 1/min.	P1 máx W	Cons. A	Cond. µF		
VS 8-150	1 x 230V~	1" Latón	1400	52	0,26	2,5	150	3,1
VS 16-150	1 x 230V~		1400	70,5	0,35	2	150	3,5
VS 35-150	1 x 230V~		2680	67,5	0,32	2	150	3,1
VS 65-150	1 x 230V~		2680	121	0,58	3	150	3,1

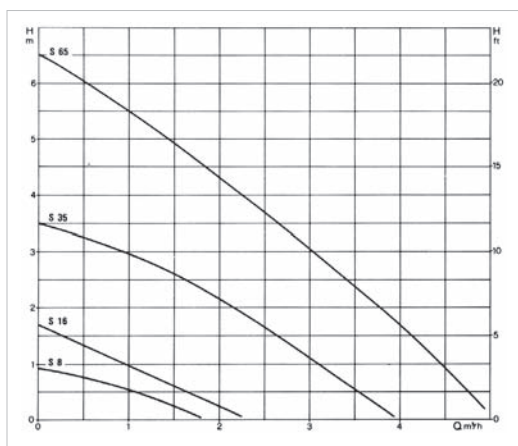

Centrífugas Circuladoras

Serie "ALM-ALP"



■ Aplicaciones:

Bomba de circulación para instalaciones de calefacción, refrigeración y agua caliente sanitaria de tipo cerrado o a vaso abierto.

■ Características Constructivas:

Cuerpo bomba y soporte motor en fundición para ALM 500 - ALP 2000, en bronce para los modelos ALM 200 - ALP 800.

Turbina en Tecnopolímero B, sello mecánico en carbón/cerámica. Eje Rotor en acero inoxidable.

Motor de tipo asíncrono, cerrado y refrigerado a ventilación externa a 4 polos para las ALM y a 2 polos para las ALP.

Protección Termoamperimétrica y condensador permanente incorporado en versión monofásica.

Construcción SEGUN NORMATIVAS CEI.

Campo de Prestaciones: de 2 a 8,5 m³/h. hasta 20 mts.

Líquido de Bombeado: Limpio, sin sustancias sólidas, no viscoso, no cristalizado y químicamente neutro.

Campo de Temperatura del líquido: de -15° C a + 120° C.

Máxima Temperatura ambiente: + 40° C.

Máxima Presión de Trabajo: 10 bar (1.000 Kpa).

Grado de Protección: IP-44.

Cuadro de Aislamiento: F.

■ Applications:

Circulation pump for hot or cold water in-line connections, suitable for installation in series directly to the piping in civil and industrial heating, conditioning and hot water plants.

■ Constructional features of the pump

Pump body and motor support in cast iron for ALM 500 and ALP 2000, and in bronze for ALM 200 and ALP 800.

Intake and delivery connection: 1" 1/2 M-GAS for ALM 200 and ALP 800 and 2" M-GAS for ALM 500 and ALP 2000.

Technopolymer impeller, carbon/ceramic mechanical seal. Constructional features of the motor. Induction motor, closed and cooled with external ventilation, four-pole for the ALM version and two-pole for the ALP version.

Rotor mounted on oversized, greased-for-life ball bearings to guarantee silent running and long life.

Manufactured according to: CEI 2-3 standards

ALM 200 - ALP 800

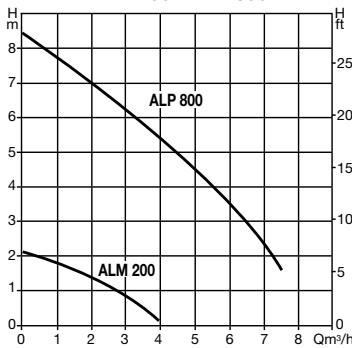

ALM 500 - ALP 2000

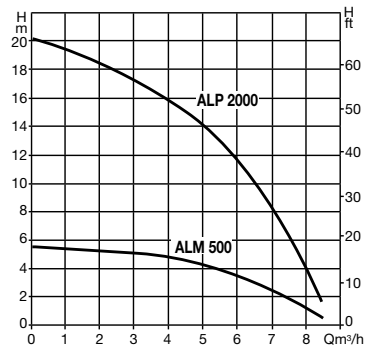

Tipo Type	Alimentación 50 HZ	Rácores	Datos Eléctricos						Entre Ejes mm.	Peso Kg.
			r.p.m. 1/min.	P1 máx W	P2 NOMINAL KW	HP	Cons. A	Cond. µF		
ALM 200 M	1 x 230 V~	1" F	1380	95	0,06	0,08	0,5	5	180	7
ALM 200 T	3 x 230/400 V~	1" F	1380	70	0,06	0,08	0,5-0,3	-	180	7
ALP 800 M	1 x 230 V~	1" F	2820	210	0,37	0,5	2,5	12,5	180	7
ALP 800 T	3 x 230/400 V~	1" F	2820	200	0,37	0,5	2-1,2	-	180	7
ALM 500 M	1 x 230 V~	1 1/4" F	1380	220	0,25	0,33	1,1	5	250	14
ALM 500 T	3 x 230/400 V~	1 1/4" F	1380	210	0,25	0,33	1,1-0,63	-	250	14
ALP 2000 M	1 x 230 V~	1 1/4" F	2820	750	0,55	0,75	3,8	16	250	14
ALP 2000 T	3 x 230/400 V~	1 1/4" F	2820	700	0,55	0,75	2,5-1,45	-	250	14



■ **Aplicaciones:**

Bomba de circulación para instalaciones de calefacción, refrigeración y agua caliente sanitaria de tipo cerrado o a vaso abierto.

■ **Características Constructivas:**

Cuerpo bomba y soporte motor en fundición. Turbina en tecnopolímero B, sello mecánico en carbón/cerámica. Eje rotor en acero inoxidable.

Motor tipo asincrono, cerrado y refrigerado a ventilación externa a 4 polos para las KLM y a 2 polos para las KLP.

Protección term-amperimétrica y condensador permanente incorporado en versión monofásica.

Construcción según Normativas CEI.

Campo de prestaciones: de 2 a 70 m³/h hasta 12 mts.

Líquido bombeado:

Limpio, sin sustancias sólidas, no viscoso, no cristalizado y químicamente neutro.

Campo de temperatura del líquido: de -15° C a + 120° C.

Máxima temperatura ambiente: + 40° C

Máxima presión de trabajo: 10 bar (1000 Kpa).

Grado de protección: IP 44 caja bornes IP 55 (DN 50-65-80)

Grado de aislamiento: F.



■ **Applications:** Circulation pump for hot or cold water in-line connections, suitable for installation in series directly to the piping in civil and industrial heating, conditioning and hot water plants.

■ **Constructional features of the pump:** Pump body and motor support in cast iron. Flanged suction and delivery connections in PN 10 with threaded holes for control pressure gauges. This range can also accept counterflanges in PN 6 in order to facilitate pump interchange in existing installations.

Technopolymer impeller. Carbon/ceramic mechanical seal. The twin version allows the pumps to be used alternately where a backup unit is required or used simultaneously.

Tipo Type	Alimentación 50 HZ	Bridas	Datos Eléctricos						Entre Ejes mm.	Peso Kg.
			r.p.m. 1/min.	P1 máx W	P2 NOMINAL KW	HP	Cons. A	Cond. µF		
KLM-DKLM 40/300 M	1 x 230 V~	DN 40-PN 10	1400	0,23	0,25	0,33	1,15	5	250	17/40
KLM-DKLM 40/300 T	3 x 230/400 V~	DN 40-PN 10	1400	0,22	0,25	0,33	1,1 - 0,63	-	250	17/40
KLP-DKLP 40/600 M	1 x 230 V~	DN 40-PN 10	2800	0,55	0,37	0,5	2,6	10	250	18/41
KLP-DKLP 40/600 T	3 x 230/400 V~	DN 40-PN 10	2850	0,5	0,37	0,5	1,9 - 1,1	-	250	18/41
KLP-DKLP 40/900 M	1 x 230 V~	DN 40-PN 10	2800	0,6	0,37	0,5	2,8	10	250	19/42
KLP-DKLP 40/900 T	3 x 230/400 V~	DN 40-PN 10	2850	0,57	0,37	0,5	2,1 - 1,2	-	250	19/42
KLP-DKLP 40/1200 M	1 x 230 V~	DN 40-PN 10	2800	0,75	0,55	0,75	3,8	14	250	20/43
KLP-DKLP 40/1200 T	3 x 230/400 V~	DN 40-PN 10	2850	0,7	0,55	0,75	2,4 - 1,4	-	250	20/43
KLM-DKLM 50/300 M	1 x 230 V~	DN 50-PN 10	1370	0,36	0,25	0,33	1,85	10	280	24/44
KLM-DKLM 50/300 T	3 x 230/400 V~	DN 50-PN 10	1370	0,3	0,25	0,33	1,2 - 0,7	-	280	24/44
KLM-DKLM 50/600 M	1 x 230 V~	DN 50-PN 10	1370	0,45	0,25	0,33	2,1	10	280	26/51
KLM-DKLM 50/600 T	3 x 230/400 V~	DN 50-PN 10	1370	0,4	0,25	0,33	1,4 - 0,8	-	280	26/51
KLP-DKLP 50/900 M	1 x 230 V~	DN 50-PN 10	2800	0,93	0,75	1	4,2	25	280	27/52
KLP-DKLP 50/900 T	3 x 230/400 V~	DN 50-PN 10	2800	0,73	0,75	1	2,8 - 1,6	-	280	27/52
KLP-DKLP 50/1200 M	1 x 230 V~	DN 50-PN 10	2800	1,1	0,75	1	5	25	280	29/54
KLP-DKLP 50/1200 T	3 x 230/400 V~	DN 50-PN 10	2800	1,05	0,75	1	3,3 - 1,9	-	280	29/54
KLM-DKLM 65/300 T	3 x 230/400 V~	DN 65-PN 10	1350	0,4	0,25	0,33	1,4 - 0,8	-	340	26/49
KLM-DKLM 65/600 T	3 x 230/400 V~	DN 65-PN 10	1380	0,55	0,37	0,5	2 - 1,15	-	340	30/55
KLP-DKLP 65/900 T	3 x 230/400 V~	DN 65-PN 10	2820	1,05	1,1	1,5	3,8 - 2,2	-	340	32/57
KLP-DKLP 65/1200 T	3 x 230/400 V~	DN 65-PN 10	2820	1,45	1,1	1,5	4,7 - 2,7	-	340	34/61
KLM-DKLM 80/300 T	3 x 230/400 V~	DN 80-PN 10	1350	0,4	0,25	0,33	1,4 - 0,8	-	360	32/47
KLM-DKLM 80/600 T	3 x 230/400 V~	DN 80-PN 10	1400	1	0,75	1	3,4 - 1,95	-	360	36/63
KLP-DKLP 80/900 T	3 x 230/400 V~	DN 80-PN 10	2820	1,8	1,84	2,5	6,3 - 3,6	-	360	38/68
KLP-DKLP 80/1200 T	3 x 230/400 V~	DN 80-PN 10	2820	2,4	1,84	2,5	7,6 - 4,4	-	360	42/75

DN 40

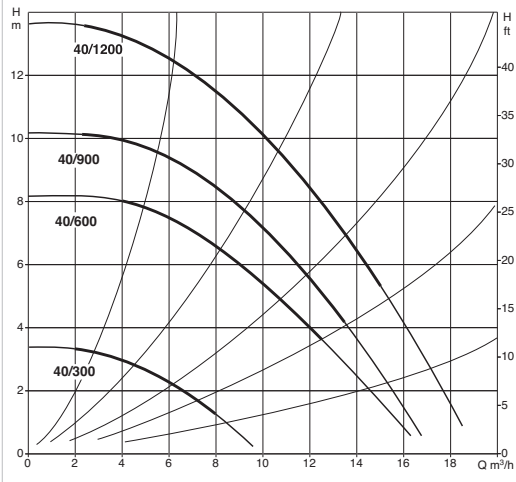

DN 50

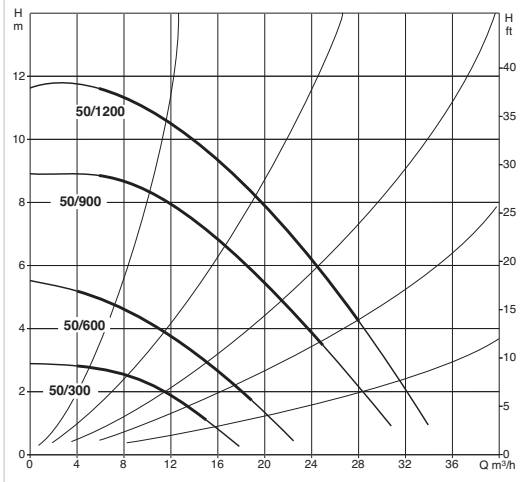

DN 65

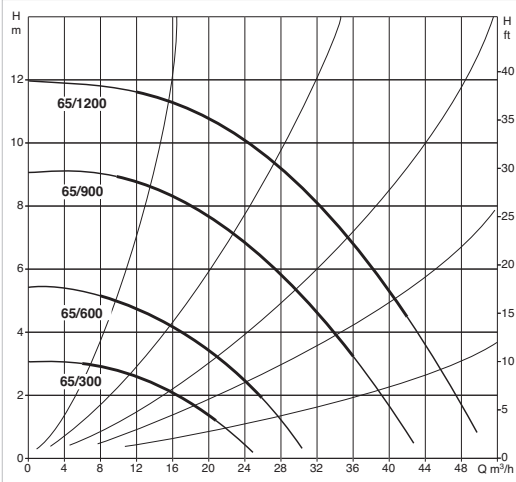

DN 80

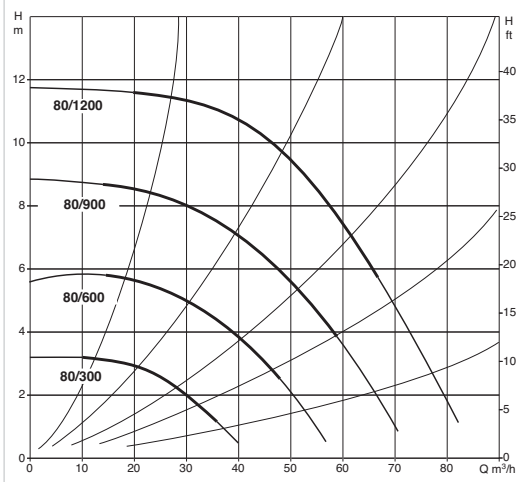



■ **Aplicaciones:**

Bomba de circulación para instalaciones de calefacción, refrigeración y agua caliente sanitaria de tipo cerrado o a vaso abierto.

■ **Características Constructivas:**

Cuerpo bomba, soporte motor, turbina y tapa ventilador en fundición.

De SERIE con contrabridas.

Sello mecánico en carbón/cerámica.

Eje Rotor en acero inoxidable.

Motor de tipo asíncrono, cerrado y refrigerado a ventilación externa a 4 polos.

CONSTRUCCIÓN SEGUN NORMATIVAS CEI.

Campo de Prestaciones: de 6 a 420 m³/h hasta 41 mts.

Líquido Bombeado: Limpio, sin sustancias sólidas, no viscoso, no cristalizado y químicamente neutro.

Campo de Temperatura del líquido: de -15° C a + 120° C.

Máxima Temperatura ambiente: + 40° C.

Máxima Presión de Trabajo: 16 bar (1.600 Kpa).

Grado de Protección: IP-44 caja bornes IP-55.

Grado de Aislamiento: F.

■ **Applications:** Circulating pump with in-line connections, suitable for civil and industrial heating, conditioning, refrigeration and hot water for plumbing.

■ **Constructional features of the pump:** Body and support in cast iron. Cast iron impeller for all models from CM 65 to CM 150 and in tephnopolymer for models from CM 40 to CM 50. Flanged suction and delivery connections in PN 16 with threaded holes for control pressure gauges. Carbon/ceramic mechanical seal.

■ **Constructional features of the motor:** Four-pole induction motor, closed and cooled with external ventilation. Rotor mounted on oversized, greased-for-life ball bearings to guarantee silent running and long life.

DISPONEMOS DE TODA LA SERIE DE ROTOR SECO EN VERSIONES CON BOMBA GEMELA Y VERSIONES "E" QUE INCLUYEN VARIADOR DE FRECUENCIA PARA CONSEGUIR UNA PRESIÓN DIFERENCIAL CONSTANTE. INCLUYEN TRANSDUCTOR DE PRESIÓN DIFERENCIAL

CM - 40

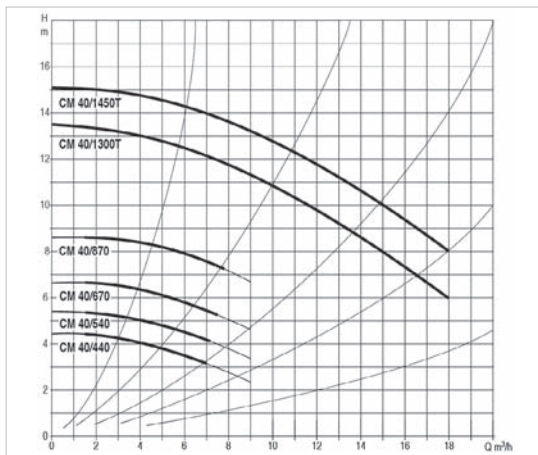

CM - 50

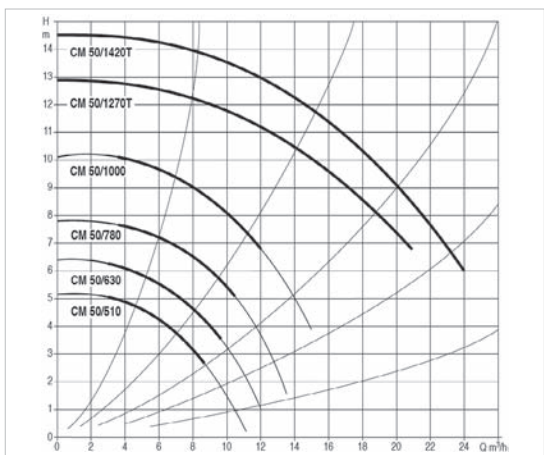

CM - 65

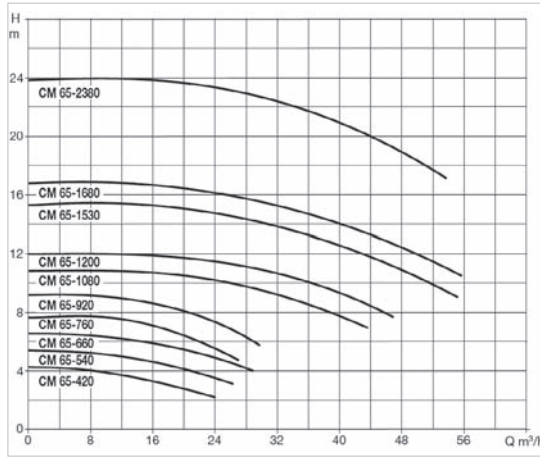

CM - 80

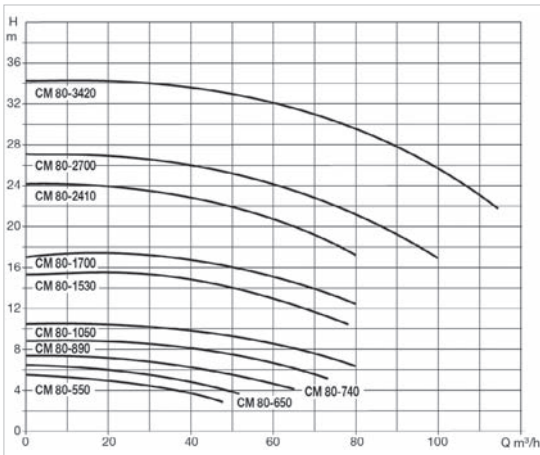

CM - 100

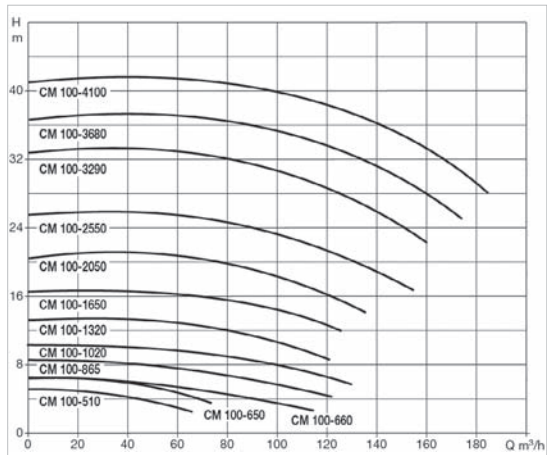

CM - 125

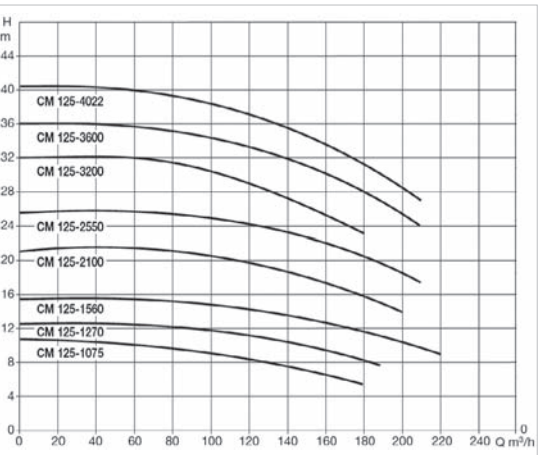

CM - 150

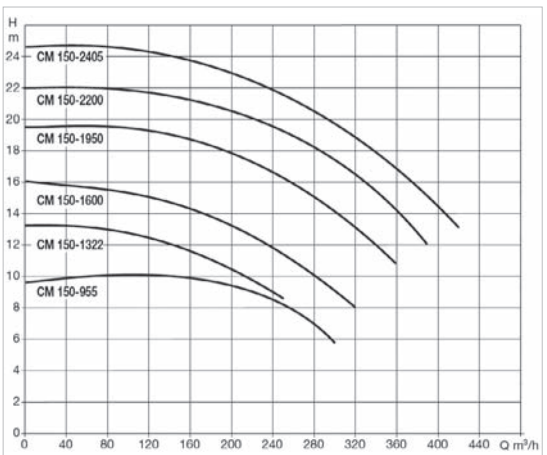

CP - 40

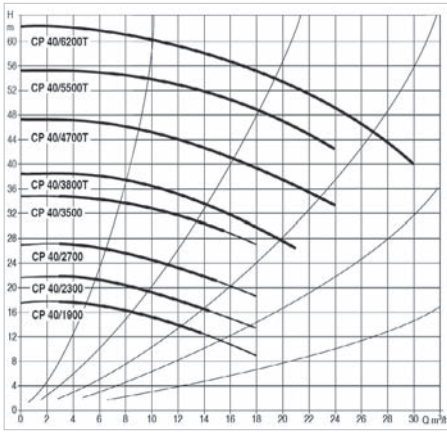

CP - 50

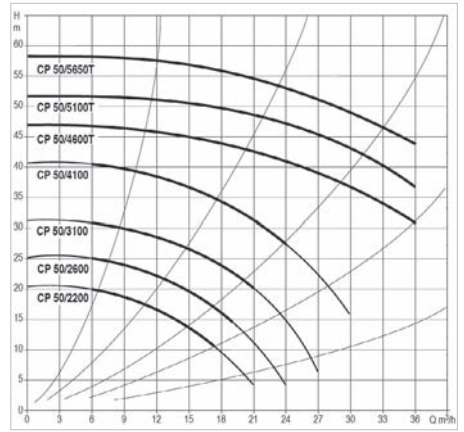

CP - 65

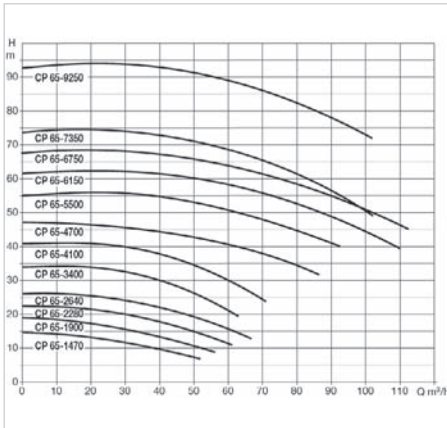

CP - 80

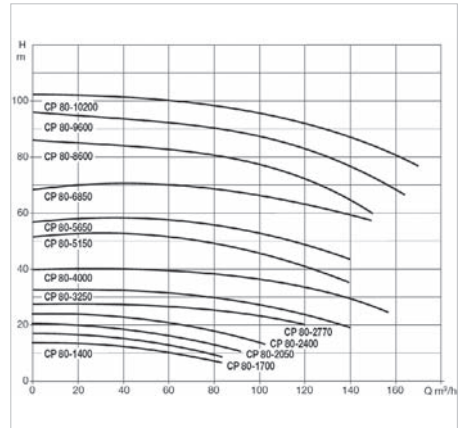

CP - 100

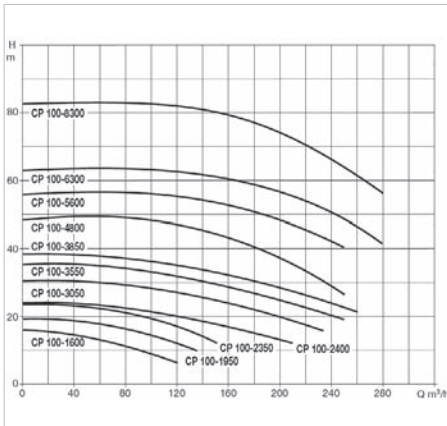

CP - 125

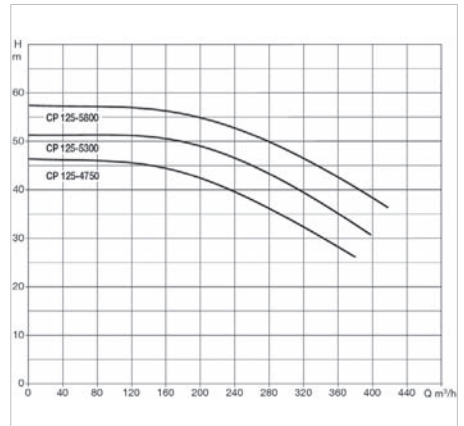

PARA MAS INFORMACION CONSULTAR NUESTRO CATALOGO TECNICO DE CIRCULADORAS
CHECK OUR TECHNICAL CATALOGUE OF CIRCULATING PUMPS FOR MORE INFORMATION

Serie "PRESSCONTROL-MASCONTROL-CONTROLPRES" 148

Serie "EASYVARIO" 149

ACCESORIOS

Válvula de Pie, Retención 150

Caudalímetros 150

Presostatos 151

Manómetros 151

Interruptor de Nivel 151

Rácor de 5 Vías 151

Serie "PRESSCONTROL-MASCONTROL-CONTROLPRES"



Presscontrol



Mascontrol



Controlpres

■ Aplicaciones:

Los controladores de presión **Presscontrol-Mascontrol-Controlpres** son unos presurizadores de nueva concepción equipados con un sistema electrónico estudiado para ordenar los datos de presión y flujo procedentes de una onda magnética emitida por un sensor. Este exclusivo sistema controla automáticamente el funcionamiento de la electrobomba para mantener una presión y caudal constante, evitando de esta manera la fastidiosa variación de presión que se produce en los sistemas tradicionales con depósito acumulador.

El **Controlpres** es un sistema de control para electrobombas que, además de las características de los anteriores dispositivos permite la regulación (reducción) de la presión máxima generada por la bomba hasta llegar al valor de presión deseado.

■ Características constructivas:

Grado de Protección IP-65.

El Presscontrol, Mascontrol y el Controlpres equipan un pequeño panel en la parte frontal de aparato con indicadores luminosos de:

- Conectado a tensión
- Bomba en marcha
- Fallo (por falta de agua o sobre consumo)

Eliminación del golpe de ariete gracias a un muelle regulador tarado.

Paro automático de la bomba en caso de falta de agua, evitando el funcionamiento en seco, que produciría averías.

Características	PRESSCONTROL	MASCONTROL	CONTROLPRES
Tensión monofásica / single ph.	230 V.	230 V.	230 V.
Intensidad máxima / max. int.	10 A.	16 A.	16 A.
Frecuencia / Frequency	50-60 Hz.	50-60 Hz.	50-60 Hz.
Campo regulación de la presión	-	-	2,5 - 7 bar
Presión máx. admitida / max. press.	10 bar	10 bar	10 bar
Conexiones / Connections	1"	1 1/4"	1 1/4"
Presión arranque	1,5 bar	1,5 bar	1,5 bar

■ Applications:

Presscontrol - Mascontrol - Controlpres pressure controllers are pressurisers with a new conception, fitted with an electronic system intended to order the pressure and flow data of a magnetic wave emitted by a sensor. This exclusive system automatically controls the working of the electropump to maintain a constant pressure and flow, thus avoiding the annoying pressure changes that occur in traditional systems with an accumulator tank.

CONTROLPRES is an electronic system, that permits the regulation (reducing) of the maximum pressure of the pump

■ Construction:

IP-65 protection.

The Presscontrol, Mascontrol and Controlpres have a small panel on the front of the apparatus with light indicators for:

- Turned on
- Pump running
- Failure (empty water or overload)

Elimination of water hammer shock absorber knock by means of a gauged regulator spring.

Automatic pump stop in the event of a lack of water, preventing the dry working that causes breakdowns

USO ADECUADO PARA VIVIENDAS MONO Y PLURIFAMILIARES, BOMBAS SUMERGIBLES PARA POZO RIEGOS DE JARDIN, INDUSTRIAS, CAMPINGS, ETC.

El desnivel desde el aparato hasta el punto más alto de utilización no debe superar los 15 m.c.a.

No necesita ninguna regulación ni mantenimiento

THE MAXIMUM HEIGHT TO THE HIGHER POINT OF THE INSTALLATION CAN NOT BE HIGHER THAN 15 m.c.a.



POSICIONES DE TRABAJO / WORKING POSITIONS



■ Descripción:

El EV es un nuevo sistema compacto para el control de bombas a VELOCIDAD VARIABLE capaz de mantener la presión CONSTANTE en la instalación al cambiar el caudal de demanda (de hecho funciona de igual forma al equipo convencional con variador de frecuencia pero integrando una serie de ventajas muy interesantes).

Está compuesto por un Variador de velocidad, un sensor de presión y un sensor de flujo lo que hace de él un sistema extremadamente compacto y sencillo de instalar. A su vez el sistema al estar totalmente integrado es sencillo de programar y puede adaptarse a equipos de presión de una o varias bombas (máximo 6 bombas en paralelo), en este ultimo caso, cada bomba deberá incorporar un EV activándose a través del cable de conexión el software de comunicación que hace que actúen en modo Principal-Auxiliar/es y alternando entre ellas en cada arranque.

■ Ventajas Principales:

- 1-Extremadamente SILENCIOSO.
 - 2-Sencilla Instalación.
 - 3-Ahorro de espacio. Evitamos la instalación de grandes acumuladores.
 - 4-Sencilla Programación.(Solo programamos Presión de trabajo y consumo bomba).
 - 5-Protección Amperométrica de la bomba (exceso de consumo).
 - 6-Protección contra trabajo en seco. (falta de agua).
 - 7-Ahorro energético muy importante.
 - 8-Trabajo a presión fija.
 - 9-Evitamos golpes de ariete y sobrepresiones en la Instalación.
- Ø Entrada (asp): 1 1/4" mach. Ø de Salida (imp): 1 1/2" hem.
 - IP-55, temperatura máxima 50° C

■ Description:

The EV is a new compact system for controlling VARIABLE SPEED pumps, capable of maintaining a CONSTANT pressure in the installation when the demand flow is changed (in fact it works in the same way as the conventional unit with a frequency inverter, but including a series of very useful advantages).

It comprises a speed inverter, a pressure sensor and a flow sensor, which make it an extremely compact system and easy to install. In turn, as the system is fully integrated, it is simple to programme and may be adapted to pressure units of one or several pumps (maximum 6 pumps in parallel); in this last case each pump must include a EV activating the communications software through a connection cable, making them work in Main-Auxiliary mode and alternating between them on each start-up.

■ Main advantages:

- 1-Extremely SILENT.
 - 2-Simple installation.
 - 3-Saves space. We avoid installing large accumulators.
 - 4-Simple programming (we only programme the working pressure and pump consumption).
 - 5-Amperometric protection of the pump (excessive consumption).
 - 6-Protection against dry working (lack of water).
 - 7-Very large energy savings.
 - 8-Work at a fixed pressure.
 - 9-We avoid ram knocks and over-pressure in the installation.
- Inlet Ø: 1 1/4" male. Outlet Ø: 1 1/2" female.
 - IP-55, maximum temperature 50° C

Modelo	Tensión Entrada (Alimentación)	Tensión Salida (Motor)	Amperaje máximo (A)	Regulación (bar)	Conectividad variadores
EVB MM-4,3 A	1 x 230 V monofásico	1 x 230 V monofásico	4,3 A	1 - 6 bar	NO
EVB MM-8,5 A	1 x 230 V monofásico	1 x 230 V monofásico	8,5 A	1 - 6 bar	NO
EVB MT2-4,5 A	1 x 230 V monofásico	3 x 230 V trifásico	4,5 A	1 - 9 bar	NO
EVD MT2-10,5 A	1 x 230 V monofásico	3 x 230 V trifásico	10,5 A	1 - 15 bar	SI
EVD TT3-7,5 A	3 x 400 V trifásico	3 x 400 V trifásico	7,5 A	1 - 15 bar	SI
EVD TT3-13,3 A	3 x 400 V trifásico	3 x 400 V trifásico	13,3 A	1 - 15 bar	SI



VALVULAS DE PIE / Foot Valve	3/4"	1"	1 1/4"	1 1/2"	2"	2 1/2"	3"	4"
VAL. RETENCIÓN / Retention Valve								

VALVULAS PIE
FOOT VALVE



VALVULAS RETENCIÓN
RETENTION VALVE



INYECTOR DE AIRE / AIR INJECTOR



Tipo / Type	Depósitos tanks lts.
MINI	0 - 500 P.max 6 bar
MIDI	0 - 1000 P.max 8 bar
MAXI	1000 - 2000 P.max 8 bar

CAUDALÍMETRO
FLOW METER



Caudalímetro Flow meter	Caudal / Flow max.	Caudal / Flow min.
2"	33.000	9.000
2 1/2"	54.000	15.000
3"	67.500	18.000
4"	120.000	30.000
6"	234.000	54.000

ANTIARIETE

Capacidad Capacity lts.	Presión Pressure bar
0,16	20
25	
50	
100	
200	
350	



EMPALME TERMORRETRACTIL



LIMITES APLICACION
PARA CABLES

DE Ø 8 A Ø 25

CIERRES MECANICOS
MECHANICAL SEAL



PRESOSTATOS / PRESSURE GAUGE



SQUARE D

Tipo	Reg. Kgs/cm ²	Conexión	Descripción
FSG-2	1,4 - 4,6	1/4" Gas	
FYG-22	2,8 - 7		
FYG-32	5,6 - 10,5		
FSG-2/M4	1,4 - 4,6	1/4" Gas	Con dispositivo de seguridad, desconexión a falta de presión de alimentación
FXG-2	1 - 6		INVERSADO

TELEMECANICA

Tipo	Reg. Kgs/cm ²	Conexión
TELEM 6 Kg.	0,9 - 6	1/4" Gas
TELEM 12 Kg.	1,3 - 12	

SACI

Tipo	Reg. Kgs/cm ²	Conexión
SK-2	1,4 - 4,6	1/4" Gas

**RACOR 5 VIAS
5 WAY FITTING**



MANOMETRO / MANOMETER



INTERRUPTOR DE BOYA / SWITCH LEVEL



SACI - 2
LLENADO O VACIADO
DE DEPOSITOS

INCLUYE 2 METROS DE CABLE

NORMAL Y GLICERINA
0 - 10 Kg./cm²

Conexión 1/4" Gas

MANGUITO ANTIVIBRATORIO



1"	1 1/4"	1 1/2"	2"
LONGITUD 600 m.			



Serie "OSMOSIS INVERSA DOMÉSTICA"

153

Serie "DESCALCIFICADORES"

154

Serie "FILTROS DE CARTUCHO"

156

Serie "OSMOSIS INVERSA DOMÉSTICA"



■ Aplicaciones:

Equipos de osmosis inversa domésticos para la producción de agua con un bajo contenido en sales, libre de virus y contaminantes químicos.

■ Características:

Equipos de funcionamiento automático sin electricidad. Grifo dispensador cromado de caño largo. Acumulador de membrana en polipropileno, para acumulación del agua osmotizada. Capacidad 11 lts. a 3,5 kg/cm². Racords de conexión rápidos. Completamente ensamblados. Incluyen tubos y accesorios de instalación. Relación Rechazo-Producto 3-1. Salinidad máxima 2.500 mg/l. Límites presión de trabajo 2,5-6 bar. Temperatura de trabajo 5° a 35° C. El rendimiento de los equipos es variable en función de distintos parámetros como la presión, temperatura, salinidad del agua y estado de los distintos elementos.

■ Descripción modelo:

Modelo GENIUS-4/75

Equipo osmosis inversa 5 etapas. Filtración + decoloración GAC + decoloración + membrana osmosis inversa + carbón activo in-line.

■ Applications:

The domestic reverse osmosis are ideal to have water with low content of salt, free of viruses and toxic chemical products.

■ Characteristics:

Automatic filtration without electricity. Chromium-plating long neck tap. Membrane accumulator in polypropylene, to storage osmotized water. Capacity 11 lts/m at 3,5 Kg/cm². includes fast connections, and are presented completely assembled.

The relation between rejected and product is a 3 to 1. The maximum saliniti 2.500 mg/l.

Pressure limits go to from 2,5 bar to 6 bar.

Water temperature 5°-35° C.

The rendiment of set may vary depending on different factors such as pressure, temperature, salinity, etc...

■ Description:

Model GENIUS - 4/75

Reverse osmosis in 5 stages. Filtration + decoloration GAC+ decoloration + reverse osmosis membrane + in-line active carbon.

Modelo	Membrana	Producción	Rechazo
Osmosis inv. GENIUS-4/75	75 gdp	100 litros/día	>90%



Descalcificador Compacto



Descalcificador By-bloc



Válvula Volumétrica

■ Aplicaciones:

El agua en su ciclo hidrológico al filtrarse en la tierra o escurrirse, disuelve las sales minerales que constituyen su salinidad. Parte de estas sales (cálcicas y magnésicas) son causa de la **dureza**, que es causa de graves problemas, incrustaciones y averías en las tuberías e instalaciones, ropa áspera, piel seca, lavados, aclarados y acabados deficientes, electrodomésticos deficientes son prueba de ello. Los descalcificadores de Bombas Saci han sido construidos con componentes de gran robustez y fiabilidad. Nuestra gama de descalcificadores con dos posibilidades distintas de control, (cronométrico o volumétrico), diseñados y optimizados para responder a todas las necesidades domésticas y profesionales que puedan presentarse garantizan plenamente la satisfacción de su elección.

■ Descalcificador Compacto:

Descalcificadores automáticos de construcción en un solo cuerpo, diseñados para cubrir las necesidades de la mayoría de viviendas con poca disponibilidad de espacio.

■ Descalcificador By-bloc:

Descalcificadores by-bloc, tanque de resinas intercambiadoras y depósito de sal separados, diseñados para aplicaciones domésticas, colectivas e industriales de pequeño y mediano caudal.

■ Control Cronométrico:

Descalcificadores de funcionamiento electromecánico, con control cronométrico. La regeneración se inicia automáticamente sobre un programa de 1 a 7 días predeterminado en función de las características de la instalación y modelo de aparato, a la hora predeterminada y controlada por un reloj diario.

■ Applications:

In its cycle, when it filters into the land or drains off, water dissolves the mineral salts that make up its salinity. Part of these salts (calcium and magnesium salts) are the cause of hardness which is responsible for serious problems, incrustations and faults in pipes and installations, rough clothes, dry skin, deficient washing, rinsing and finishing, faulty household electrical appliances are a sign of this. Bombas Saci softener have been manufactured with strong, reliable components. Our range of softener with two different control possibilities (timed or volumetric), designed and optimised to respond to all possible domestic and professional requirements, fully guarantee satisfaction in your choice.

■ Compact softener:

Automatic softener with a single body construction, designed to cover the needs of most homes with little space.

■ By-bloc softener:

By-bloc softener, exchanger resins tank and separate salt deposit, designed for domestic, collective and industrial small and medium-flow applications.

■ Timed Control:

Softener with electromechanical working. Regeneration begins automatically on a pre-set program of 1 to 7 days, which depends on the characteristics of the installation and the model of equipment, at a set time controlled by a daily clock.

■ Control Volumétrico:

Descalcificadores controlados por microprocesador, de control por volumen. La regeneración se inicia automáticamente en función del agua, modelo de aparato, consumo de agua tratada controlado por el contador de agua integrado en la válvula y control de constante del microprocesador que determina el momento más adecuado para el inicio de la regeneración. Consiguiendo de este modo un funcionamiento más económico gracias a un importante ahorro de agua y sal regenerante.

Todos los descalcificadores equipan de serie señalizaciones que indican que proceso se está realizando.

Opcionalmente recomendamos la instalación del by-pass, y un filtro de cartucho en la entrada.

■ Pasos a seguir para averiguar el descalcificador necesario:

- 1.º - Determinar la dureza del agua en ° HF (grados franceses), mediante un comprobador (por debajo de 25 ° HF no se requiere descalcificador). Para uso industrial a partir de 0° HF es necesario.
- 2.º - Calcular el consumo de agua diario (en circunstancias normales el consumo doméstico puede ser 200 litros/persona/día). El caudal resultante diario lo multiplicamos por 3 para hacer una regeneración cada 3 días.
- 3.º - Con el consumo de caudal (x 3) obtenido en el paso anterior (Ciclo entre Regeneraciones) y la dureza en ° HF (con rangos desde 25 hasta 50 ° HF), localizar en la tabla los litros de resina que necesitamos. De esta manera podremos determinar el tipo de descalcificador necesario para nuestra instalación.

■ Volumetric Control:

Microprocessor-controlled softener, controlled by volume. Regeneration begins automatically depending on the water, model of equipment, treated water consumption controlled by the water counter built into the constant valve and control of the microprocessor, which determines the best time to start regeneration, thus achieving more economical running thanks to significant savings in water and regenerating salt.

All softener have signals as standard that indicate the process that is being performed.

As an option, we recommend that the by-pass should be installed, as well as a cartridge filter on the inlet.

■ Steps for determining the decalcifier that is required:

- 1.º - Determine the hardness of the water in ° HF (French degrees) using a checker (under 25 ° HF, no decalcifier needed). For industrial use, one is necessary from 0° HF.
- 2.º - Calculate the daily water consumption (under normal circumstances, domestic consumption may be 200 litres / person / day). The resulting daily flow is multiplied by 3 to make a generation every 3 days.
- 3.º - With the flow consumption (x3) obtained in the previous step (cycle between regenerations) and the hardness in ° HF (with ranges from 25 to 50 ° HF), find the litres of resin we need from the table. In this way we are able to determine the kind of decalcifier we need for our installation.

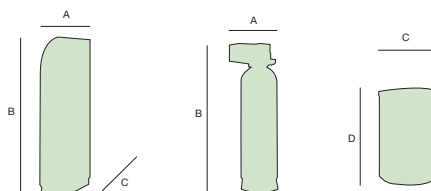

Litros Resina	Capacidad Intercambio °Hf x m³	Caudal Máximo m³/h	Consumo Sal Kgs.	Ciclo entre regeneraciones m³						Dimensiones				
				20°	30°	40°	50°	60°	70°	A	B	C	D	Depósito sal
8 Comp.	48	0,8	1,6	2,4	1,6	1,2	1	0,8	0,6	310	650	425		75 Lts.
12 Comp.	72	0,9	2,4	3,6	2,4	1,8	1,4	1,2	1,1	310	1.120	425		75 Lts.
15 Comp./ By bloc	90	1,2	3	4,5	3	2,2	1,8	1,5	1,3	310	1.120	425	680	100 Lts.
20 Comp./ By bloc	120	1,6	4	6	4	3	2,4	2	1,7	310	1.120	425	680	100 Lts.
25 Comp.	150	2	5	7,5	5	3,8	3	2,5	2,1	310	1.120	425		100 Lts.
30 Comp./By bloc	180	2,4	6	9	6	4,5	3,6	3	2,6	310	1.120	425	100	100 Lts.
45 By bloc	270	2,8	9	13,5	9	6,7	5,4	4,5	3,8	255	1.590	530	800	150 Lts.
70 By bloc	420	2,8	14	21	14	11	8,4	7	6	330	1.590	530	1.050	200 Lts.
100 By bloc	600	4	20	30	20	15	12	10	9	355	1.950	750	1.150	300 Lts.
125 By bloc	750	5	25	38	25	19	15	13	11	405	1.950	750	1.150	300 Lts.





Los Filtros de Cartucho son generalmente utilizados en el marco doméstico e industrial para la eliminación de partículas en suspensión y de todos aquellos sabores, debidos a la excesiva cloración del agua.

Cartridge Filters are generally used in domestic and industrial circumstances to eliminate particles in suspension and all undesired tastes caused by excessive chlorine in the water.

PORTACARTUCHOS	LONGITUD	CONEXIONES
	10"	1"

■ PORTACARTUCHOS:

Están constituidos por materiales atóxicos e idóneos para uso alimentario. Rácor de entrada, salida y purgador en latón. Carcasa transparente para verificar el estado del cartucho.

■ CARTUCHOS FILTRANTES:

Existen diversos tipo de cartuchos, según la necesidad que se requiere.

- Polipropileno bobinado:** cartucho apropiado para uso alimentario, cuya función básica es la de suprimir las partículas en suspensión como arena, óxido, etc.
- Malla lavable:** cartucho apropiado para uso alimentario, cuya función básica es la de suprimir las partículas en suspensión como arena, óxido, etc. Su ventaja principal estriba en que es lavable.
- Carbón activo:** cartucho apropiado para uso alimentario, cuya función básica es la de depurar y dechlorar las sustancias químicas disueltas en el agua, evitando de esta manera, los olores y sabores producidos por estas.
- Polifosfatos:** el agua en contacto con los polifosfatos sufre un tratamiento que elimina los nefastos efectos de la cal. Es aconsejable su instalación a la salida de descalcificadores.

■ CARTRIDGE HOLDER:

They are made in atoxic materials ideal for use with foodstuffs. Inlet, outlet and bleeder connections in brass. Transparent housing to check the state of the cartridge.

■ FILTERING CARTRIDGES:

There are several types of cartridges, depending on the required needs.

- Reeled polypropylene:** a cartridge suitable for use with foodstuffs, the basic function of which is to eliminate the particles in suspension, such as sand, rust, etc.
- Washable mesh:** a cartridge suitable for use with foodstuffs, the basic function of which is to eliminate particles in suspension, such as sand, rust, etc. The main advantage lies in the fact that it is washable.
- Active carbon:** a cartridge suitable for use with foodstuffs, the basic function of which is to purify and dechlorinate the chemical substances dissolved in the water, thus preventing the smells and tastes caused by them.
- Polyphosphates:** the water in contact with the polyphosphates undergoes a treatment that eliminates the harmful effects of lime. It should be installed on the outlet of decalcifiers.

TIPO / TYPE	CONEXIONES CONEXIONS	FILTRACION FILTRATION	CAUDAL MAXIMO MAXIMUM FLOW	PRESION MAXIMA MAXIMUM PRESSURE	TEMPERATURA MAX. MAX. TEMPERATURE
POLIPROPILENO BOBINADO	1"	50 micras	2,2 m ³ /h	8 Kg/cm ²	45° C
MALLA LAVABLE	1"	80 micras	2,8 m ³ /h	8 Kg/cm ²	45° C
CARBON ACTIVO	1"	5 micras	2,8 m ³ /h	8 Kg/cm ²	45° C
POLIFOSFATOS	1"	-	2,8 m ³ /h	8 Kg/cm ²	45° C

Serie "IDROPRESS - EXPANSORES"	158
Serie "ACUMULADOR"	159
Serie "VASOS CALEFACCIÓN AGUA SANITARIA"	160
Serie "GALVANIZADOS"	161
Serie "PRESSURE WAVE - CHALLENGER"	162



MEMBRANA RECAMBIABLE.

HOMOLOGADOS POR EL MINISTERIO DE INDUSTRIA Y CONFORMES A LA DIRECTIVA 97/23/CE.

TEMPERATURA MÁXIMA DE SERVICIO: 100° C

MANUFACTURED ACCORDING TO THE EUROPEAN DIRECTIVE 97/23/CE ON PRESSURE EQUIPMENT.

Construidos en chapa de acero embutido con acabado exterior fosfatado pintado y secado. Versiones inox. en chapa de acero inox. 304. Con membrana de caucho sintético, atóxica e intercambiable. Ideal para uso alimentario.

Replaceable bladder hidropneumatic tanks with synthetic rubber bladder painted in ral 3013.

Maximum working temperature: 100° C

EXPANSORES DE MEMBRANA

Expansores	Presión	Ø D Diámetro	H - Altura	Ø Conexión	Figura
Exp. 5 lts.	10 BAR	200	265	1"	A
Exp. 15 lts.	10 BAR	270	320	1"	B
Exp. 25 lts.	8 BAR	350	410	3/4"	A
Exp. 25 lts.	8 BAR	350	410	1"	A
Exp. 25 lts. inox.	8 BAR	350	410	1"	A
Exp. 50 lts.	10 BAR	360	620	1"	B
Exp. 50 lts.	16 BAR	360	640	1"	B

FIGURA A



FIGURA B



IDROPRESS HORIZONTAL DE MEMBRANA

Expansores	Presión	L - Largo	H - Altura	Ø Conexión	Figura
Idropress 20 lts.	10 BAR	425	270	1"	C
Idropress 50 lts.	10 BAR	620	360	1"	C
Idropress 50 lts. inox.	10 BAR	620	360	1"	C
Idropress 80 lts.	10 BAR	625	450	1"	C

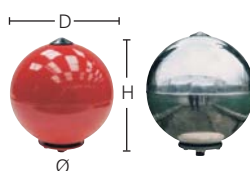
FIGURA C



Construidos en chapa de acero embutido con acabado exterior fosfatado pintado y secado.

The correct air pressure for the tanks in the installations should be 0.2 Kg/cm2 below the starting pressure of the pumps.

This pressure should be checked periodically

EXPANSORES DE MEMBRANA HIDROCARBUROS (Gas-oil)

Expansores	Presión	Ø D Diámetro	H - Altura	Ø Conexión	Figura
2 lts. Gas-oil	3 BAR	230	130	3/4"	-
5 lts. Gas-oil	10 BAR	200	265	3/4"	A
15 lts. Gas-oil	10 BAR	270	320	3/4"	B
25 lts. Gas-oil	8 BAR	350	410	3/4"	A



La presión de aire idonea que deben tener los depósitos, debe de ser 0,2 bar inferior a la presión de arranque de las bombas. Esta presión debe ser revisada periódicamente.



FIGURA D



FIGURA E

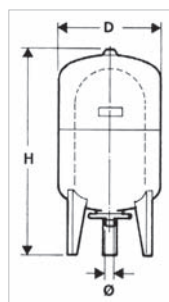

FIGURA F

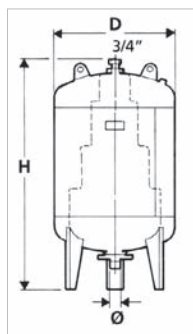

■ DEPOSITOS DE MEMBRANA:

Construidos en chapa de acero embutido con acabado exterior fosfatado pintado y secado. Con membrana de caucho sintético, atóxica e intercambiable. Especial para uso alimenticio. Bajo demanda se pueden suministrar en construcción horizontal.

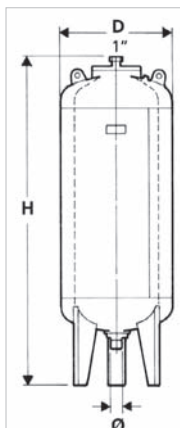
Temperatura máxima de servicio: 100° C.

Homologados por el Ministerio de Industria y conformes a la directiva 97/23/CE.

La presión de aire idonea que deben tener los depósitos en las instalaciones, debe de ser de 0,2 bar inferior a la presión de arranque de las bombas. Esta presión se debe revisar periódicamente.

■ MEMBRANE TANKS:

Built in stuffed steel plate with phosphated, painted and dried exterior finish.

With diaphragm in disposable atoxic synthetic rubber, special for use with foodstuffs.

On request, it may be supplied in a horizontal construction.

Service temperature 100° C.

MANUFACTURED ACCORDING TO THE EUROPEAN DIRECTIVE 97/23/CE ON PRESSURE EQUIPMENT.

The correct air pressure for the tanks in the installations should be 0.2 Kg/cm2 below the starting pressure of the pumps.

This pressure should be checked periodically

ACUMULADORES DE MEMBRANA

ACUMULADORES	PRESION	Ø D DIAMETRO	H - ALTURA	Ø CONEXION	FIGURA
Acum. 50 lts.	10 BAR	360	760	1"	D
Acum. 50 lts. inox.		360	760	1"	D
Acum. 80 lts.		450	750	1"	D
Acum. 100 lts.		450	870	1"	D
Acum. 100 lts. inox.		450	870	1"	D
Acum. 150 lts. fuelle		485	1.080	1 1/4"	E
Acum. 200 lts. fuelle		550	1.075	1 1/4"	E
Acum. 300 lts. fuelle		650	1.178	1 1/4"	E
Acum. 500 lts.		600	2.065	1 1/2"	F
Acum. 500 lts. fuelle		750	1.450	1 1/2"	E
Acum. 700 lts.		700	2.085	1 1/2"	F
Acum. 700 lts. fuelle	8 BAR	800	1.700	1 1/2"	E
Acum. 900 lts.	10 BAR	800	2.155	1 1/2"	F
Acum. 1.400 lts.		1.000	2.320	2"	F
Acum. 2.000 lts.		1.200	2.630	DN 80	F
Acum. 3.000 lts.		1.200	3.630	DN 80	F

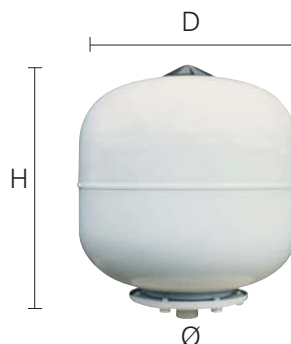

■ Vasos de Expansión de membrana fija destinados a trabajar en inst. de calefacción y refrigeración para absorber los aumentos de volumen producidos por la elevación de la temperatura. Construidos en chapa de acero de la calidad y espesor que responden a las normas Técnicas exigidas. Membrana en SBR.

Homologados por el Ministerio de Industria y conformes a la directiva 97/23/CE.

TEMPERATURA MÁXIMA DEL AGUA: 100 ° C

■ Fixed bladder expansion vessel are designed for working in water heating and cooling systems to absorb the volume increase when temperature goes up. Maximum water temperature: 100° C.

MANUFACTURED ACCORDING TO THE EUROPEAN DIRECTIVE 97/23/CE ON PRESSURE EQUIPMENT.

Capacidad Capacity Litros	Presión Máxima Max. pressure bar	Dimensiones / Dimensions		Salida / Outlet Ø
		D mm.	H mm.	
5	8	200	240	3/4"
8	4	200	328	3/4"
12	4	270	305	3/4"
18	4	270	405	3/4"
25	8	320	425	3/4"
35	4	360	465	3/4"
50	4	360	630	3/4"
80	6	485	590	1"
100	6	485	655	1"
140	6	485	945	1"
200	6	600	875	1"
250	6	600	1.105	1"
300	6	600	1.270	1"
400	6	600	1.510	1"

Vasos de Expansión Agua Caliente Sanitaria:
pintados de blanco.

Hot sanitary water expansion vessel:
White painted.

Capacidad Capacity Litros	Presión Máxima Max. pressure bar	Dimensiones / Dimensions		Salida / Outlet Ø
		D mm.	H mm.	
5	10	200	245	3/4"
8	10	200	350	3/4"
11	10	270	320	3/4"
18	10	270	425	3/4"
25	8	350	410	1"

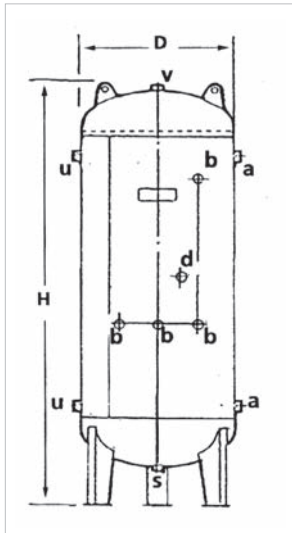

■ Características constructivas:

Construidos en chapa de acero y galvanizados en caliente tanto interior como exteriormente, completados con tomas para todos los accesorios, requeridas para su perfecta instalación. Bajo demanda se pueden suministrar en construcción horizontal.

HOMOLOGADOS POR EL MINISTERIO DE INDUSTRIA Y CONFORMES A LA DIRECTIVA 97/23/CE.

ATENCIÓN: En caso de necesitar el depósito galvanizado para un equipo de presión, recuerden escoger un inyector de aire para cada bomba del equipo. Debemos tener en cuenta que para depósitos de hasta 1.000 lts. el inyector idóneo es el I-600, y para depósitos de 1.000 a 2.000 lts. el idóneo es el SP-II.

■ Construction:

Built in steel plate and hot galvanized on the inside and outside, completed with sockets for all accessories required for a perfect installation. On request they may be supplied in a horizontal construction.

MANUFACTURED ACCORDING TO THE EUROPEAN DIRECTIVE 97/23/CE ON PRESSURE EQUIPMENT.

Capacidad litros	Presión max. de trabajo BAR	D Ø Exterior	H mm.	a-u	d	V - S	b
100	10	400	1.090	1 1/2"	-	1 1/2"	1/2"
200	10	500	1.385	1 1/2"	-	1 1/2"	1/2"
300	10	550	1.615	1 1/2"	-	1 1/2"	1/2"
500	8	650	1.860	1 1/2"	-	1 1/2"	1/2"
750	8	750	2.080	1 1/2"	-	1 1/2"	1/2"
1.000	8	800	2.373	1 1/2"	-	1 1/2"	1/2"
1.250	8	900	2.380	2"	1 1/2"	1 1/2"	1/2"
1.500	8	950	2.465	2"	1 1/2"	1 1/2"	1/2"
2.000	8	1.100	2.490	2"	1 1/2"	1 1/2"	1/2"
2.500	8	1.100	3.045	2 1/2"	1 1/2"	1 1/2"	1/2"
3.000	8	1.200	3.200	2 1/2"	1 1/2"	1 1/2"	1/2"
4.000	8	1.400	3.140	4"	1 1/2"	1 1/2"	1/2"
5.000	8	1.400	3.790	4"	1 1/2"	1 1/2"	1/2"

Para otras presiones de trabajo, consultar a nuestro Departamento Técnico.
For other working pressures, contact our technical Department.



5 AÑOS DE GARANTIA
5 YEAR WARRANTY

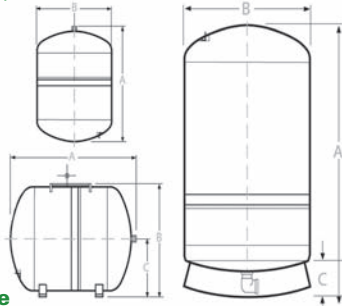

Serie Pressure wave

Depósitos de membrana fija en butilo de alto grado, no recambiable, aptos para agua caliente/fría. Incluyen revestimiento interior del depósito en la parte mojada en polipropileno virgen, que hace innecesario cualquier tipo de mantenimiento, revestimiento exterior en poliuretano sobre base de epoxi. Conexión de entrada y salida en acero inoxidable. Incluyen válvula de aire anti-escape.

Tipo / Type	Presión Máxima Max. pressure bar	Dimensiones / Dimensions			Salida / Outlet Ø
		A mm.	B mm.	C mm.	
PEWB 24	10	360	280	-	1"
PWB 35 Vertical	10	555	318	120	1"
PWB 60 Vertical	10	626	388	104	1"
PWB 80 Vertical	10	790	388	104	1"
PWB 100 Vertical	10	626	388	104	1"
PWB 150 Vertical	10	790	388	104	1"
PWB 20 Horizontal	10	439	289	151	1"
PWB 60 Horizontal	10	528	414	213	1"
PWB 80 Horizontal	10	724	414	216	1"

5 AÑOS DE GARANTIA
5 YEAR WARRANTY



Serie Challenger

Depósitos de doble membrana fija en butilo de alto grado, no recambiable, aptos para agua caliente/fría. Carecen de cualquier tipo de mantenimiento, revestimiento exterior en poliuretano sobre base de epoxi. Conexión de entrada y salida en acero inoxidable. Incluyen válvula de aire anti-escape.

Tipo / Type	Presión Máxima Max. pressure bar	Dimensiones / Dimensions				Salida / Outlet Ø
		A mm.	B mm.	C mm.	D mm.	
GC 200	10	1033	533	66	431	1 1/4"
GC 240	10	1212	533	66	431	1 1/4"
GC 310	10	1500	533	66	431	1 1/4"
GC 450	10	1529	660	69	540	1 1/4"

Equipos EASY VARIO SYSTEM 1 bomba	164
Equipos EASY VARIO SYSTEM 2 bombas	165
Especificaciones Equipos Presión	166
Cálculo de Equipos de Presión	167
Tabla Selección Eq. Presión Bombas V-NOX - VAT	172
Tabla Selección Eq. Presión Bombas XV	174
Tabla Selección Eq. Presión Bombas K - MN	176
Especificaciones Eq. Contra incendios	178
Eq. Contra incendios norma UNE 23-500-90	
Tabla de Selec. Eq. C.I. Serie UE 1 Principal Eléctrica	182
Tabla de Selec. Eq. C.I. Serie UEE 2 Principales Eléctricas	183
Tabla de Selec. Eq. C.I. Serie UD 1 Principal Diesel	184
Tabla de Selec. Eq. C.I. Serie UED 1 Pral. Eléctrica y 1 Principal Diesel	185
Eq. Contra incendios norma CEPREVEN RT2-ABA	
Tabla de Selec. Eq. C.I. Serie CE 1 Principal Eléctrica	186
Tabla de Selec. Eq. C.I. Serie CEE 2 Principales Eléctricas	187
Tabla de Selec. Eq. C.I. Serie CD 1 Principal Diesel	188
Tabla de Selec. Eq. C.I. Serie CED 1 Pral. Eléctrica y 1 Principal Diesel	189
Cuadros Eléctricos	
Cuadros Eléctricos Equipos de Presión y Bombas de Aguas Fecales	190
Cuadros Eléctricos con Arrancador Progresivo	191
Cuadros Eléctricos VARIO-SYSTEM con Variador de Frecuencia	192
Cuadros Eléct. Equipos Contra incendios	193
Cuadros Eléctricos Bombas de Piscina	194
Cuadros Eléct. Bombas Sumergibles de Pozo	194

■ Los grupos de presión EASY VARIO de una sola bomba han sido diseñados y fabricados para satisfacer las necesidades de presión constante a variaciones de caudal en las más modernas instalaciones incorporando además ventajas tan excepcionales como un importante AHORRO ENERGÉTICO y un comportamiento ABSOLUTAMENTE SILENCIOSO.

■ Funcionamiento:

Para empezar a trabajar solo debemos programar la presión de trabajo que deseamos en la instalación, para lo cual pulsamos dos teclas y la predefinimos en el display. Cuando la presión de trabajo desciende a causa de un consumo de agua, la bomba entra en funcionamiento automáticamente manteniendo la presión absolutamente constante en la instalación, a medida que vamos aumentando la demanda de agua el variador va aumentando la frecuencia de la bomba hasta hacerla llegar a su velocidad máxima. El grupo para automáticamente en el momento que se supere el valor de presión de trabajo programado en una secuencia igual pero inversa a la descrita para su arranque.

En caso de falta de agua en la alimentación del grupo, el variador EV lo detecta inmediatamente y para la bomba automáticamente para evitar daños en el grupo.

■ The EASY VARIO pressure units with a single pump have been designed and manufactured to satisfy the need for constant pressure with flow variations in the most modern installations, also including such exceptional advantages as considerable ENERGY SAVINGS and an ABSOLUTELY SILENT behaviour.

■ Operation:

To start work, we just have to programme the working pressure we want in the installation, for which we press two keys and predefine it on the display. When the working pressure falls due to water consumption, the pump automatically comes into operation, maintaining an absolutely constant pressure in the installation; as we increase the demand for water, the inverter increases the frequency of the pump



until it reaches its maximum speed. The unit will stop automatically when the working pressure value is exceeded that is programmed in sequence, the same but inversely to that described for starting.

If there is a lack of water in the unit supply, the EV inverter detects it immediately and stops the pump automatically to avoid damage to the unit.

Tipo Type	Pot. HP	Alimentación Entrada Equipo	Caudal m ³ /h / Flow m ³ /h									Diámetro	
			1,5	3	4,5	6	7	8	9	10	11	ASP.	IMP.
			Altura m.c.a. / Height w.c.m.										
EASY VARIO 1 x V-NOX 303	1,2	230 V Mono	39	37	35	32	28	24	20	14	8	1 1/2"	1 1/4"
EASY VARIO 1 x V-NOX 304	1,5	230 V Mono	51	50	46	42	37	32	26	18	12	1 1/2"	1 1/4"
EASY VARIO 1 x V-NOX 305	2	230 V Mono	65	62	58	52	46	40	32	24	14	1 1/2"	1 1/4"
EASY VARIO 1 x V-NOX 306	3	230 V Mono	77	75	70	63	56	48	38	28	16	1 1/2"	1 1/4"
EASY VARIO 1 x V-NOX 307	3	230 V Mono	90	86	79	70	65	54	42	32	18	1 1/2"	1 1/4"
EASY VARIO 1 x V-NOX 308	4	400 V Trif	103	100	92	84	74	64	52	36	21	1 1/2"	1 1/4"
EASY VARIO 1 x V-NOX 309	4	400 V Trif	117	112	104	92	83	70	56	42	23	1 1/2"	1 1/4"
EASY VARIO 1 x V-NOX 310	5,5	400 V Trif	129	124	116	104	92	79	64	48	26	1 1/2"	1 1/4"

Tipo Type	Pot. HP	Alimentación Entrada Equipo	Caudal m ³ /h / Flow m ³ /h									Diámetro	
			1,5	3	4,5	6	9	12	15	18	21	ASP.	IMP.
			Altura m.c.a. / Height w.c.m.										
EASY VARIO 1 x V-NOX 403	2	230 V Mono	35	34	33	32	30	28	24	19	12	1 1/2"	1 1/4"
EASY VARIO 1 x V-NOX 404	3	230 V Mono	46	45	44	43	40	36	31	24	14	1 1/2"	1 1/4"
EASY VARIO 1 x V-NOX 405	4	400 V Trif	58	57	55	54	50	46	40	31	18	1 1/2"	1 1/4"
EASY VARIO 1 x V-NOX 406	4	400 V Trif	70	69	67	65	61	56	49	37	23	1 1/2"	1 1/4"
EASY VARIO 1 x V-NOX 407	5,5	400 V Trif	82	81	79	77	71	65	57	45	28	1 1/2"	1 1/4"

Equipos de 2 bombas con variador EASY VARIO

Serie "EASY VARIO 2 x V-NOX"

■ Los grupos de presión EASY VARIO de dos bombas han sido diseñados y fabricados para satisfacer las necesidades de presión constante a variaciones de caudal en las más modernas instalaciones incorporando además ventajas tan excepcionales como un importante AHORRO ENERGÉTICO y un comportamiento ABSOLUTAMENTE SILENCIOSO. Principalmente aptos para suministro de agua a presión a edificios, industrias, riegos etc...

Con este sistema no debemos olvidar que tenemos un equipo de dos bombas con dos variadores, lo cual significa que en caso de desconexión de un variador, siempre tenemos el otro para seguir funcionando de igual modo.

■ Funcionamiento:

Para empezar a trabajar solo debemos programar la presión de trabajo que deseamos en la instalación, para lo cual pulsamos dos teclas y la predefinimos en el display. Cuando la presión de trabajo desciende a causa de un consumo de agua la primera bomba entra en funcionamiento automáticamente manteniendo la presión absolutamente constante en la instalación, a medida que vamos aumentando la demanda de agua el variador va aumentando la frecuencia de la bomba hasta hacerla llegar a su velocidad máxima en aquel punto si continua el aumento de demanda de agua entrará en funcionamiento la segunda bomba (auxiliar) para seguir manteniendo la presión de trabajo fija. El grupo y las bombas pararan automáticamente en el momento que se supere el valor de presión de trabajo programado en una secuencia igual pero inversa a la descrita para su arranque.

El grupo alternará en cada arranque el orden de entrada de las bombas. En caso de falta de agua en la alimentación del grupo, el variador lo detecta inmediatamente y para la bomba automáticamente para evitar daños en el grupo.

■ The EASY VARIO pressure units with two pumps have been designed and manufactured to satisfy the need for constant pressure with flow variations in the most modern installations, also including such exceptional advantages as considerable ENERGY SAVINGS and an ABSOLUTELY SILENT behaviour. Mainly suitable for supplying pressurised water to buildings, industries, sprinklers, etc.



Las fotografías pueden mostrar elementos opcionales disponibles bajo demanda.

Pictures can show optional accessories available on demand

With this system, we must not forget that we have the two-pump unit with two inverters, which means that in the event of disconnecting one inverter, we always have the other to continue working in the same way.

■ Operation:

To start work, we just have to programme the working pressure we want in the installation, for which we press two keys and predefine it on the display. When the working pressure falls due to water consumption, the first pump automatically comes into operation, keeping the pressure absolutely constant in the installation as we increase the frequency of the pump to reach maximum speed. At this point, if the demand for water continues to increase, the second pump will start up (auxiliary) to continue to maintain a fixed working pressure. The unit and the pumps will stop automatically when the working pressure value is exceeded that is programmed in sequence, the same but inversely to that described for starting. The unit will alternate the input order of the pumps on each start-up. If there is a lack of water in the unit supply, the inverter detects it immediately and stops the pump automatically to avoid damage to the unit.

Tipo Type	Pot.	Alimentacion Entrada Equipo	Caudal m ³ /h 2 bombas / Flow m ³ /h 2 pumps									Diámetro	
			3	6	9	12	14	16	18	20	22		
	HP	Caudal m ³ /h 1 bomba / Flow m ³ /h 1 pump									ASP.	IMP.	
			Altura m.c.a. / Height w.c.m.										
EASY VARIO 2 x V-NOX 303	2 x 1,2	230 V Mono	39	37	35	32	28	24	20	14	8	11/2"	21/2"
EASY VARIO 2 x V-NOX 304	2 x 1,5	230 V Mono	51	50	46	42	37	32	26	18	12	11/2"	21/2"
EASY VARIO 2 x V-NOX 305	2 x 2	230 V Mono	65	62	58	52	46	40	32	24	14	11/2"	21/2"
EASY VARIO 2 x V-NOX 306	2 x 3	230 V Mono	77	75	70	63	56	48	38	28	16	11/2"	21/2"
EASY VARIO 2 x V-NOX 307	2 x 3	230 V Mono	90	86	79	70	65	54	42	32	18	11/2"	21/2"
EASY VARIO 2 x V-NOX 308	2 x 4	400 V Trif	103	100	92	84	74	64	52	36	21	11/2"	21/2"
EASY VARIO 2 x V-NOX 309	2 x 4	400 V Trif	117	112	104	92	83	70	56	42	23	11/2"	21/2"
EASY VARIO 2 x V-NOX 310	2 x 5,5	400 V Trif	129	124	116	104	92	79	64	48	26	11/2"	21/2"

Tipo Type	Pot.	Alimentacion Entrada Equipo	Caudal m ³ /h 2 bombas / Flow m ³ /h 2 pumps									Diámetro	
			3	6	9	12	18	24	30	36	42		
	HP	Caudal m ³ /h 1 bomba / Flow m ³ /h 1 pump									ASP.	IMP.	
			Altura m.c.a. / Height w.c.m.										
EASY VARIO 2 x V-NOX 403	2 x 2	230 V Mono	35	34	33	32	30	28	24	19	12	11/2"	21/2"
EASY VARIO 2 x V-NOX 404	2 x 3	230 V Mono	46	45	44	43	40	36	31	24	14	11/2"	21/2"
EASY VARIO 2 x V-NOX 405	2 x 4	400 V Trif	58	57	55	54	50	46	40	31	18	11/2"	21/2"
EASY VARIO 2 x V-NOX 406	2 x 4	400 V Trif	70	69	67	65	61	56	49	37	23	11/2"	21/2"
EASY VARIO 2 x V-NOX 407	2 x 5,5	400 V Trif	82	81	79	77	71	65	57	45	28	11/2"	21/2"

• Para otros equipos rogamos seleccionen equipos VARIO SYSTEM standard o consulten con nuestro departamento técnico.





■ APLICACIONES:

Los equipos de presión son conjuntos diseñados para el suministro automático de agua a presión a distintos tipos de instalaciones como pueden ser: bloques de viviendas, apartamentos, urbanizaciones, riegos, edificios comerciales, hoteles, instalaciones deportivas, industrias, etc.

■ SERIES:

1) Equipos de presión con cuadro eléctrico standard:

El control de la Presión se lleva a cabo mediante Presostatos y Depósito de Acumulación.

2) Equipos de presión Vario System con variador de frecuencia:

Control por Variador de Frecuencia para suministro de agua en aquellas Instalaciones más exigentes donde existan fluctuaciones de caudal y se requiera presión constante además de otras muchas ventajas tales como: presión constante, ahorro energético, eliminación golpe de ariete.

■ Equipos compuestos por:

Bomba(s), 1, 2 ó 3 presostatos, manómetro de glicerina, bancada general con soporte cuadro eléctrico, colector de impulsión compuesto con válvulas de bola y válvulas de retención, cuadro eléctrico de mando y protección incluyendo transductor de presión y un pequeño acumulador sólo para las versiones con variador de frecuencia.

En las siguientes tablas se indican 3 ejecuciones ya sean bombas verticales series V-NOX - VAT o Serie VX o bombas K - MN.

■ CALCULO DE EQUIPOS:

Para la selección del caudal en Equipos de Presión deben seguirse las "Normas Básicas para las Instalaciones Interiores de suministro de Agua" OM de 9.12.75 publicada en el BOE el 13.01.1976. Donde se establecen los Caudales y Presiones necesarias así como los Depósitos de Acumulación.

■ DETERMINACION DEL CAUDAL NECESARIO PARA BLOQUES DE VIVIENDAS:

El caudal de la bomba funcionando en el límite más alto de presión deberá aproximarse lo más posible a los valores expresados en la Tabla 1 en litros por minuto, en función del número de suministros que alimenta.

■ APLICATIONS:

The pressure units are units designed to automatically supply pressurised water to different kinds of installations, such as: housing blocks, apartments, housing estates, irrigation, commercial buildings, hotels, sport installations, industries, etc.

■ SERIES

1) Pressure units with standard electrical panel:

The pressure is controlled by Pressure Gauges and Pressure Tanks.

2) Vario System pressure units with frequency converter:

Controlled by Frequency Converter, for water supply in more demanding installations where there are fluctuations in the flow and constant pressure is required, as well as many other advantages .

■ Our booster sets includes:

1, 2 or 3 pumps and pressure gauges, 1 glycerine manometer, 1 base plate with control box support, general outlet collector with one retention valve and close valve for each pump, electrical control box with standard equipment or with inverter including the pressure trasducer.

At the next tables you can choose between three types of sets:

- Vertical pumps
- Vertical pumps in stainless steel
- Horizontal pump

■ UNIT CALCULATION:

To select the pressure units, it is necessary to follow the "Basic Rules for Interior Water Supply Installations" OM of 9.12.75 published in the Official State Bulletin on 13.01.1976, establishing the necessary Flows and Pressures and the Pressure Tanks.

■ DETERMINATION OF THE NECESSARY FLOW

For housing blocks:

The flow of the pump working at the highest pressure limit, must come as close as possible to the values expressed in Table 1 in litres per minute, depending on the number of supplies it feeds.

CAUDAL DE LA BOMBA EN / PUMPS FLOW IN m³/h

Nº de viviendas Nº of housing	TIPO / TYPE A	TIPO / TYPE B	TIPO / TYPE C	TIPO / TYPE D	TIPO / TYPE E
0 - 10	1,5	2,1	3	3,6	4,5
11 - 20	2,4	3,6	5,1	6	7,5
21 - 30	3,6	4,5	6,6	8,4	10,8
31 - 50	5,4	9	10,8	13,2	16,8
51 - 75	9	13,2	15	17,4	19,2
76 - 100	12	16,2	17,4	19,2	-
101 - 150	15	18	19,2	-	-

Zona sombreada mínimo 2 o más bombas en paralelo / Needed two or more pumps in paralel

CHECK OUR TECHNICAL CATALOGUE FOR MORE INFORMATION

■ DETERMINACION DE LA PRESION DE TRABAJO:

La Altura Manométrica requerida o Presión de arranque vendrá definida por la siguiente suma:

$$Pa = Hg + Pc + Hr + Ha$$

Ejemplo: tenemos un edificio de 4 plantas + 2 sótanos, el grupo de presión está situado en el primer sótano y con una altura de aspiración de 3,5 m.c.a.

La presión de servicio o de trabajo será:

Hg (Altura Geométrica): (4 plantas + 1 sótano) x 3 m.c.a. = 15 m.c.a.

Pc (Pérdidas de Carga 15% de Hg): 15% de 15 m.c.a. = 2,25 m.c.a.

Hr (Presión necesaria en el punto más alto) = 20 m.c.a. (orientativo)

Ha (Altura de Aspiración) = 3,5 m.c.a.

$$Pa = Hg + Pc + Hr + Ha = 15 \text{ m.c.a.} + 2,25 \text{ m.c.a.} + 20 \text{ m.c.a.} + 3,5 \text{ m.c.a.}$$

$$Pa = 40,75 \text{ m.c.a.} = 4,1 \text{ bar} = \text{Presión de trabajo}$$

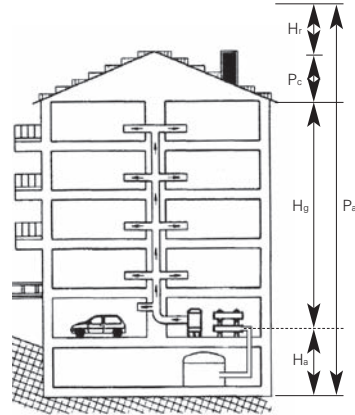

COMO GUÍA PRÁCTICA PODEMOS UTILIZAR LA SIGUIENTE TABLA:

	N.º de plantas del edificio										
	1	2	3	4	5	6	7	8	9	10	11
Presión arranque	25	30	35	40	44	48	52	56	60	65	70
Presión paro	40	45	50	55	59	63	67	71	75	80	85

■ DETERMINACION DEL DEPOSITO DE ACUMULACIÓN NECESARIO:

Tenemos 3 formas de cálculo del depósito acumulador:

A) Localizando sobre las tablas de selección adjuntas, las cuales indican el volumen mínimo de depósito de membrana requerido.

PRESION DE TRABAJO	CAUDAL LTS./H.									
	2.500	4.000	6.000	8.000	10.000	12.500	15.000	20.000	25.000	30.000
4 BAR	50 lts.	80 lts.	100 lts.	150 lts.	200 lts.	200 lts.	300 lts.	300 lts.	500 lts.	500 lts.
5 BAR	50 lts.	100 lts.	100 lts.	150 lts.	200 lts.	200 lts.	300 lts.	300 lts.	500 lts.	500 lts.
6 BAR	80 lts.	100 lts.	150 lts.	150 lts.	200 lts.	300 lts.	500 lts.	500 lts.	500 lts.	700 lts.
7 BAR	80 lts.	100 lts.	150 lts.	200 lts.	300 lts.	300 lts.	500 lts.	500 lts.	500 lts.	700 lts.
8 BAR	80 lts.	100 lts.	150 lts.	200 lts.	300 lts.	300 lts.	500 lts.	500 lts.	700 lts.	700 lts.

- Los volúmenes mínimos arriba reflejados se refieren a depósitos de membranas, para depósitos galvanizados multiplicar este volumen por 3 y añadir un inyector por bomba.

- Los equipos con variador de frecuencia ya incluyen un pequeño depósito de 25-100 lts. por lo cual no es necesario preveer ningún otro depósito.

B) Para mayores caudales, consultar el ábaco de selección de nuestro catálogo técnico de equipos.

C) Solo para viviendas y según la Normativa del Ministerio de Industria arriba citada, que establece que el volumen total del Depósito (agua + aire) en litros será igual o superior al que resulte de multiplicar los coeficientes de la siguiente tabla por el número de suministros que alimenta el recipiente.

Acumuladores de membrana

TIPO DE VIVIENDA	TIPO A	TIPO B	TIPO C	TIPO D	TIPO E
Coficiente	15	18	20	23	26

Acumuladores galvanizados

TIPO DE VIVIENDA	TIPO A	TIPO B	TIPO C	TIPO D	TIPO E
Coficiente	40	50	60	70	80

PARA OTRAS ESPECIFICACIONES CONSULTAR NUESTRO CATALOGO TECNICO DE EQUIPOS

■ DETERMINATION OF THE WORKING PRESSURE:

The Manometric Height required or starting Pressure is defined by the following sum:

$$Pa = Hg + Pc + Hr + Ha$$

Example: we have a 4 floor housing + 2 floor underground, the pressure unit is locate in the first floor below ground, and the suction head is 3,5 w.c.m.

The working pressure will be:

- Hg (Geometric Height): (4 floors + 2 Underfloor) x3 m.c.a. = 18 m.c.a.
- Pc (Load Losses): 15% de 18 m.c.a. = 2,7 m.c.a.
- Hr (Residual Height) = 20 m.c.a.
- Ha (Suction Height) = 3,5 m.c.a.

$$Pa = Hg + Pc + Hr + Ha = 18 \text{ m.c.a.} + 2,7 \text{ m.c.a.} + 20 \text{ m.c.a.} + 3,5 \text{ m.c.a.}$$

$$Pa = 44,2 \text{ m.c.a.} = 4,5 \text{ bar} = \text{Working pressure}$$

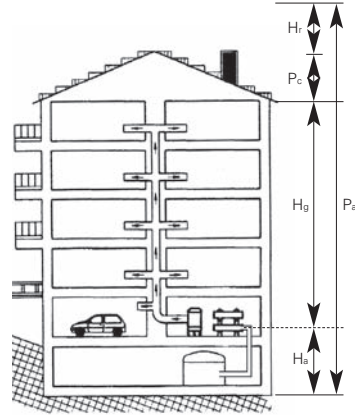

		N.º of Floors										
		1	2	3	4	5	6	7	8	9	10	11
Start pressure	w.c.m.	25	30	35	40	44	48	52	56	60	65	70
Stop pressure	w.c.m.	40	45	50	55	59	63	67	71	75	80	85

■ DETERMINATION OF THE PRESSURE TANKS VOLUME:

We have 3 options to calculate the ideal tank:

A) In the selection tables, which indicate the membrane tank minimum volume required.

WORKING PRESSURE	FLOW LTS./H.									
	2.500	4.000	6.000	8.000	10.000	12.500	15.000	20.000	25.000	30.000
4 BAR	50 lts.	80 lts.	100 lts.	150 lts.	200 lts.	200 lts.	300 lts.	300 lts.	500 lts.	500 lts.
5 BAR	50 lts.	100 lts.	100 lts.	150 lts.	200 lts.	200 lts.	300 lts.	300 lts.	500 lts.	500 lts.
6 BAR	80 lts.	100 lts.	150 lts.	150 lts.	200 lts.	300 lts.	500 lts.	500 lts.	500 lts.	700 lts.
7 BAR	80 lts.	100 lts.	150 lts.	200 lts.	300 lts.	300 lts.	500 lts.	500 lts.	500 lts.	700 lts.
8 BAR	80 lts.	100 lts.	150 lts.	200 lts.	300 lts.	300 lts.	500 lts.	500 lts.	700 lts.	700 lts.

- The minimum volumes stated above are referred to membrane tanks, for galvanized tanks we should multiply by three and add an air injector for each pump.
- Unit with an inverter already includes a small tank from 25 to 100 lts. hence, no other tank is necessary to preview.

B) For larger flows, consult the selection chart of pressure tanks, that was at the technical Catalog.

C) Only for housing and according to the above mentioned Regulations of the Ministry of Industry, which establish that the total volume of the tank (water + air) in litres will be the same or larger than that resulting from multiplying the coefficients of Table 3 by the number of supplies feeding the recipient.

Membrane tanks

TYPE OF HOUSING	TYPE A	TYPE B	TYPE C	TYPE D	TYPE E
Coefficient	15	18	20	23	26

Galvanized tanks

TYPE OF HOUSING	TYPE A	TYPE B	TYPE C	TYPE D	TYPE E
Coefficient	40	50	60	70	80

PROCEDIMIENTO PARA LA SELECCIÓN DE EQUIPOS DE PRESIÓN:

- Paso 1)** Seleccionar el punto de trabajo requerido en la instalación CAUDAL y PRESIÓN:
En caso de tener estos datos, pasar al segundo paso; en caso contrario, averiguarlo a través de la información técnica detallada en las 2 páginas anteriores del presente catálogo o bien si necesita más información consultar el catálogo técnico equipos Bombas Saci Controls.
- Paso 2)** Escoger el N° de bombas que compondrán nuestro equipo de presión, en función de si queremos todas las bombas activas o bien queremos una o más de reserva (en cuyo caso no se tendrán en cuenta estas para cubrir el caudal total necesario, pero sí se deben tener en cuenta en la composición del equipo).
- Paso 3)** Escoger el tipo de bombas que queremos en función de sus características constructivas, para ello encontraremos tres tablas de selección:
- Bombas Verticales Multicelulares con turbinas y difusores en tecnopolimero de alta resistencia o latón series: V-NOX - V - VAT. (Pág. 156-157)
 - Bombas Verticales Multicelulares con turbinas y difusores en Acero Inoxidable serie: VX (Pág. 158-159)
 - Bombas Horizontales monoturbina o biturbina series: K - HK - MN. (Pág. 160-161)
- Paso 4)** Una vez tenemos todos los datos necesarios, localizar el modelo idóneo de bomba que necesitamos sobre las tablas de selección de bombas en las que podremos observar el caudal de 1 sola bomba, de 2 bombas, de 3 bombas.
- Paso 5)** Posteriormente pasamos a las siguientes páginas para encontrar el modelo concreto de equipo que deseamos ya sea de 1,2 ó 3 bombas (recordando que en este último punto sí debemos tener en cuenta las bombas que queremos de reserva).
- Paso 6)** Por último, ya solo falta escoger el depósito acumulador que necesitamos, que tal y como se explica en la información técnica que se acompaña podemos escogerlo de diversas formas:
- Escoger el mínimo recomendado por BOMBAS SACI en función del caudal y la presión a las que debe trabajar, mediante la tabla adjunta en las páginas de especificaciones de cada equipo.
 - Para mayores caudales o presiones utilizar el ábaco de selección reflejado en Catálogo Técnico.
 - Escoger el volumen del depósito según las Normativas del Ministerio de Industria recogidas en página anterior.
- Paso 7)** Localizar el precio en TARIFA de:
- El equipo determinado ya sea con cuadro convencional o con Variador de Frecuencia (recordar que en caso de escoger el equipo con variador de frecuencia debemos anteponer la palabra VARIO delante de la denominación de equipo, por ejemplo, VARIO EP 3 x V-NOX 309.
 - El acumulador deseado de membrana o Galvanizado (+ 1 inyector por cada bomba en caso de ser galvanizado). Recuerden que los equipos con variador de frecuencia ya incorporan de serie un pequeño acumulador.

EJEMPLO DE CÁLCULO

Ejemplo: tenemos un edificio de 70 viviendas tipo E en 4 plantas + 2 sótanos, el grupo de presión debe ser de 3 bombas (dos para servicio más una en reserva) en el segundo sótano y con una altura de aspiración de 3,5 m.c.a.

Paso 1) El caudal necesario es: $Q =$ para 70 viv. tipo E = 19,2 m³/h (según tablas pag. 153)

La presión de servicio o de trabajo es: $P_a = 4,1$ bar (ejemplo pag. anterior).

Paso 2) Queremos un equipo de 3 bombas (2 bombas deben dar el caudal total + 1 de reserva)

Paso 3) Queremos escoger bombas de la Serie V.

Paso 4) Buscamos sobre las tablas de selección de bombas verticales tipo V-NOX V-VAT, equipo que con dos 2 bombas a la vez nos den 19,2 m³/h a 4,1 bar y localizamos las bombas V-NOX 309, V-52 o bien V-43 o bien VAT-127 L8, y nos quedamos con las V-52 (porque queremos turbinas y difusores en bronce).

Paso 5) La denominación del equipo que necesitamos es:

- EP 3x V-52 (si es un equipo con cuadro convencional)

- VARIO EP 3x V-52 (si es un equipo con cuadro con variador de frecuencia) ya incluye pequeño acumulador

Paso 6) Escogemos el depósito de acumulación necesario (en caso de escoger equipo con cuadro convencional)

- **Método 1:** depósito **mínimo de membrana** de 300 lts. (galvanizado mínimo de 900 lts.+3 inyectores aire)

- **Metodo 2:** según normativa (tablas página 154) depósito de membrana de 1.820 lts. (70 viv. x 26 lts.) o bien depósito galvanizado de 5.600 lts. (70 viv. x 80 lts.) + 3 inyectores de aire.

Paso 7) Localizar en tarifa precio de equipos y acumuladores necesarios y en el momento de pasar pedido, rogamos indiquen tensión de trabajo.

PARA OTRAS ESPECIFICACIONES CONSULTAR NUESTRO CATALOGO TECNICO DE EQUIPOS

PROCEDURE FOR SELECTING PRESSURE UNITS:

- Step 1)** Select the point required in the installation, FLOW and PRESSURE: If you have these data, pass on to the second step, otherwise, check with the technical information on Page 162-165 of this catalogue.
- Step 2)** Choose the number of pumps that will make up the pressure unit, depending on whether we want all the pumps active or we want one or more in reserve (in which case they will not be counted in covering the total necessary flow, but they must be borne in mind in the composition of the equipment).
- Step 3)** Choose the type of pump we want, depending on the constructive characteristics. We find three selection tables for this purpose:
- Multicellular Vertical Pumps with impellers and diffusers in high strength technopolymer or brass series: V-NOX - V - VAT. (page 168-169)
 - Multicellular Vertical Pumps with impellers and diffusers in stainless steel: VX (page 170-171)
 - Single impeller or twin impeller horizontal pumps: K - HK - MN. (page 172-173)
- Step 4)** Once we have all the necessary data, we locate the ideal kind of pump from the pump selection tables where we can see the flow for 1 single pump, 2 pumps, 3 pumps and 4 pumps
- Step 5)** Then we pass to the following pages to find specific specifications on the unit we want, that is, 1, 2, 3 or 4 pumps (remembering to bear in mind the pumps we want in reserve in this last point).
- Step 6)** Finally, we only need to choose the accumulator tank we need, which, as is explained in the technical information attached, we can choose in a variety of manners:
- Choose the minimum recommended by BOMBAS SACI depending on the flow and the pressure at which it must work, using the table attached on the specification pages of each unit.
 - For larger flows or pressure, use the selection abacus on page 5 in the technical Catalogue (B).
 - Choose the volume of the tank according to the Regulations of the Ministry of Industry presented on page 5 in the technical Catalogue (C).
- Step 7)** Locate the price in RATE of:
- The determined unit, albeit conventional or with a Frequency Inverter.
 - The membrane or galvanised tank required.

TIPO BOMBA PUMP TYPE	Potencia Bomba		CAUDAL TOTAL 3 BOMBAS / 3 PUMPS TOTAL FLOW													
	Pump Power		0	6	12	18	30	42	54	66	72	78	84	96	108	132
			CAUDAL TOTAL 2 BOMBAS / 2 PUMPS TOTAL FLOW													
			0	4	8	12	20	28	36	44	48	52	56	64	72	88
			CAUDAL TOTAL 1 BOMBA / 1 PUMPS TOTAL FLOW													
HP	KW	0	2	4	6	10	14	18	22	24	26	28	32	36	44	
		ALTURA m.c.a. / HEIGHT w.c.m.														
V-NOX 303	1,2	0,9	40	38	36	32	14									
V-NOX 304	1,5	1,1	53	51	48	42	18									
V-NOX 305	2	1,5	66	64	59	52	24									
V-NOX 306	3	2,2	79	76	72	63	28									
V-NOX 307	3	2,2	92	88	82	70	32									
V-NOX 308	4	3	106	102	95	84	36									
V-NOX 309	4	3	120	115	107	92	42									
V-NOX 310	5,5	4	133	126	119	104	48									
V-NOX 403	2	1,5	36	35	33	32	29	26	19	8						
V-NOX 404	3	2,2	47	46	44	43	38	33	24	10						
V-NOX 405	4	3	59	58	56	54	48	43	31	14						
V-NOX 406	4	3	70	69	67	64	58	52	36	17						
V-NOX 407	5,5	4	82	80	78	75	67	59	43	20						
VAT 127L-4	2	1,5	41	40	40	36	23	7								
VAT 127L-5	2	1,5	51	50	49	45	29	9								
VAT 127L-6	3	2,2	61	59	58	54	35	13								
VAT 127L-7	3	2,2	71	69	68	63	40	14								
VAT 127L-8	3	2,2	81	79	78	72	47	17								
VAT 127L-9	4	3	91	89	88	82	52	19								
VAT 127L-10	4	3	101	99	97	91	59	22								
VAT 127L-11	5,5	4	111	109	107	101	66	25								
VAT 127L-12	5,5	4	121	119	117	110	73	28								
VAT 127L-13	5,5	4	131	129	127	120	82	30								
VAT 163L-2	4	3	35	33	32,5	32	31,5	28	25	19	15	12				
VAT 163L-3	4	3	52	48	47,5	47	45	40	34	25	21	17				
VAT 163L-4	5,5	4	68	64	64,5	63	59	54	45	34	29	21				
VAT 163L-5	7,5	5,5	85	80	78	77,5	74	70	60	45	38	28				
VAT 163L-6	7,5	5,5	102	95	94	93	90	81	70	54	46	35				
VAT 163L-7	10	7,5	119	112	111	110	105	97	84	63	52	40				
VAT 163L-8	10	7,5	136	126	124	123	116	107	96	76	64	51				
VAT 163L-9	12,5	9,2	154	144	143	141	134	123	110	88	76	63				
VAT 205-2	10	7,5	53				51	50	48,5	46	45	44	43	41	39	23
VAT 205-3	12,5	9,2	79				77	75,5	74	72	70	68	66	62	58	35
VAT 205-4	20	15	105				103	100,5	98	95	93	91	88	83	77	47
VAT 205-5	20	15	132				128	125	123	120	117	114	110	104	96	58
VAT 205-6	25	18,5	158				154	150	147	143	140	137	132	120	114	70

PARA OTRAS ESPECIFICACIONES CONSULTAR NUESTRO CATALOGO TECNICO DE EQUIPOS
CHECK OUR TECHNICAL CATALOGUE FOR MORE INFORMATION

EQUIPOS 1 BOMBA
1 PUMP BOOSTER SET

TIPO EQUIPO 1 BOMBA 1 PUMP BOOSTER SET TYPE	Potencia Total Equipo HP	Ø IMP.
EP 1 x V-NOX 303	1,2	1 1/4"
EP 1 x V-NOX 304	1,5	1 1/4"
EP 1 x V-NOX 305	2	1 1/4"
EP 1 x V-NOX 306	3	1 1/4"
EP 1 x V-NOX 307	3	1 1/4"
EP 1 x V-NOX 308	4	1 1/4"
EP 1 x V-NOX 309	4	1 1/4"
EP 1 x V-NOX 310	5,5	1 1/4"
EP 1 x V-NOX 403	2	1 1/4"
EP 1 x V-NOX 404	3	1 1/4"
EP 1 x V-NOX 405	4	1 1/4"
EP 1 x V-NOX 406	4	1 1/4"
EP 1 x V-NOX 407	5,5	1 1/4"
EP 1 x VAT-127L-4	2	1 1/2"
EP 1 x VAT-127L-5	2	1 1/2"
EP 1 x VAT-127L-6	3	1 1/2"
EP 1 x VAT-127L-7	3	1 1/2"
EP 1 x VAT-127L-8	3	1 1/2"
EP 1 x VAT-127L-9	4	1 1/2"
EP 1 x VAT-127L-10	4	1 1/2"
EP 1 x VAT-127L-11	5,5	1 1/2"
EP 1 x VAT-127L-12	5,5	1 1/2"
EP 1 x VAT-127L-13	5,5	1 1/2"
EP 1 x VAT-163L-2	4	2"
EP 1 x VAT-163L-3	4	2"
EP 1 x VAT-163L-4	5,5	2"
EP 1 x VAT-163L-5	7,5	2"
EP 1 x VAT-163L-6	7,5	2"
EP 1 x VAT-163L-7	10	2"
EP 1 x VAT-163L-8	10	2"
EP 1 x VAT-163L-9	12,5	2"
EP 1 x VAT-205-2	10	2 1/2"
EP 1 x VAT-205-3	12,5	2 1/2"
EP 1 x VAT-205-4	20	2 1/2"
EP 1 x VAT-205-5	20	2 1/2"
EP 1 x VAT-205-6	25	2 1/2"

EQUIPOS 2 BOMBA
2 PUMP BOOSTER SET

TIPO EQUIPO 2 BOMBA 2 PUMP BOOSTER SET TYPE	Potencia Total Equipo HP	Ø IMP.
EP 2 x V-NOX 303	2 x 1,2	2 1/2"
EP 2 x V-NOX 304	2 x 1,5	2 1/2"
EP 2 x V-NOX 305	2 x 2	2 1/2"
EP 2 x V-NOX 306	2 x 3	2 1/2"
EP 2 x V-NOX 307	2 x 3	2 1/2"
EP 2 x V-NOX 308	2 x 4	2 1/2"
EP 2 x V-NOX 309	2 x 4	2 1/2"
EP 2 x V-NOX 310	2 x 5,5	2 1/2"
EP 2 x V-NOX 403	2 x 2	2 1/2"
EP 2 x V-NOX 404	2 x 3	2 1/2"
EP 2 x V-NOX 405	2 x 4	2 1/2"
EP 2 x V-NOX 406	2 x 4	2 1/2"
EP 2 x V-NOX 407	2 x 5,5	2 1/2"
EP 2 x VAT-127L-4	2 x 2	DN 100
EP 2 x VAT-127L-5	2 x 2	DN 100
EP 2 x VAT-127L-6	2 x 3	DN 100
EP 2 x VAT-127L-7	2 x 3	DN 100
EP 2 x VAT-127L-8	2 x 3	DN 100
EP 2 x VAT-127L-9	2 x 4	DN 100
EP 2 x VAT-127L-10	2 x 4	DN 100
EP 2 x VAT-127L-11	2 x 5,5	DN 100
EP 2 x VAT-127L-12	2 x 5,5	DN 100
EP 2 x VAT-127L-13	2 x 5,5	DN 100
EP 2 x VAT-163L-2	2 x 4	DN 100
EP 2 x VAT-163L-3	2 x 4	DN 100
EP 2 x VAT-163L-4	2 x 5,5	DN 100
EP 2 x VAT-163L-5	2 x 7,5	DN 100
EP 2 x VAT-163L-6	2 x 7,5	DN 100
EP 2 x VAT-163L-7	2 x 10	DN 100
EP 2 x VAT-163L-8	2 x 10	DN 100
EP 2 x VAT-163L-9	2 x 12,5	DN 100
EP 2 x VAT-205-2	2 x 10	DN 125
EP 2 x VAT-205-3	2 x 12,5	DN 125
EP 2 x VAT-205-4	2 x 20	DN 125
EP 2 x VAT-205-5	2 x 20	DN 125
EP 2 x VAT-205-6	2 x 25	DN 125

EQUIPOS 3 BOMBA
3 PUMP BOOSTER SET

TIPO EQUIPO 3 BOMBA 3 PUMP BOOSTER SET TYPE	Potencia Total Equipo HP	Ø IMP.
EP 3 x V-NOX 303	3 x 1,2	3"
EP 3 x V-NOX 304	3 x 1,5	3"
EP 3 x V-NOX 305	3 x 2	3"
EP 3 x V-NOX 306	3 x 3	3"
EP 3 x V-NOX 307	3 x 3	3"
EP 3 x V-NOX 308	3 x 4	3"
EP 3 x V-NOX 309	3 x 4	3"
EP 3 x V-NOX 310	3 x 5,5	3"
EP 3 x V-NOX 403	3 x 2	3"
EP 3 x V-NOX 404	3 x 3	3"
EP 3 x V-NOX 405	3 x 4	3"
EP 3 x V-NOX 406	3 x 4	3"
EP 3 x V-NOX 407	3 x 5,5	3"
EP 3 x VAT-127L-4	3 x 2	3"
EP 3 x VAT-127L-5	3 x 2	3"
EP 3 x VAT-127L-6	3 x 3	3"
EP 3 x VAT-127L-7	3 x 3	3"
EP 3 x VAT-127L-8	3 x 3	3"
EP 3 x VAT-127L-9	3 x 4	3"
EP 3 x VAT-127L-10	3 x 4	3"
EP 3 x VAT-127L-11	3 x 5,5	3"
EP 3 x VAT-127L-12	3 x 5,5	3"
EP 3 x VAT-127L-13	3 x 5,5	3"
EP 3 x VAT-163L-2	3 x 4	DN 125
EP 3 x VAT-163L-3	3 x 4	DN 125
EP 3 x VAT-163L-4	3 x 5,5	DN 125
EP 3 x VAT-163L-5	3 x 7,5	DN 125
EP 3 x VAT-163L-6	3 x 7,5	DN 125
EP 3 x VAT-163L-7	3 x 10	DN 125
EP 3 x VAT-163L-8	3 x 10	DN 125
EP 3 x VAT-163L-9	3 x 12,5	DN 125
EP 3 x VAT-205-2	3 x 10	DN 150
EP 3 x VAT-205-3	3 x 12,5	DN 150
EP 3 x VAT-205-4	3 x 20	DN 150
EP 3 x VAT-205-5	3 x 20	DN 150
EP 3 x VAT-205-6	3 x 25	DN 150

PARA OTRAS ESPECIFICACIONES CONSULTAR NUESTRO CATALOGO TECNICO DE EQUIPOS
CHECK OUR TECHNICAL CATALOGUE FOR MORE INFORMATION

TIPO BOMBA PUMP TYPE	Potencia Bomba		CAUDAL TOTAL 3 BOMBAS / 3 PUMPS TOTAL FLOW											
	Pump Power		0	6	12	18	24	30	36	42	54	66	72	84
			CAUDAL TOTAL 2 BOMBAS / 2 PUMPS TOTAL FLOW											
			0	4	8	12	16	20	24	28	36	44	48	56
	HP	KW	CAUDAL TOTAL 1 BOMBA / 1 PUMPS TOTAL FLOW											
			ALTURA m.c.a. / HEIGHT w.c.m.											
XV-F 5-8	1,5	1,1	52	48	43	33	22							
XV-F 5-10	2	1,5	65	63	56	45	32							
XV-F 5-14	3	2,2	93	91	82	67	46							
XV-F 5-16	3	2,2	107	103	93	76	53							
XV-F 5-20	4	3	135	131	119	98	69							
XV-F 5-29	5,5	4	197	192	176	148	106							
XV-F 5-36	7,5	5,5	246	236	215	181	132							
XV-F 10-6	3	2,2	59	59	59	58	54	46	37					
XV-F 10-9	4	3	90	89	89	87	81	70	57					
XV-F 10-10	5,5	4	101	100	100	98	91	79	65					
XV-F 10-12	5,5	4	121	120	120	118	108	95	77					
XV-F 10-16	7,5	5,5	162	162	162	156	145	128	114					
XV-F 10-22	10	7,5	223	223	223	218	202	178	145					
XV-F 15-5	5,5	4	68	67	67	66	65	64	62	58	51	40		
XV-F 15-7	7,5	5,5	97	97	96	95	93	90	87	82	72	59		
XV-F 15-9	10	7,5	125	123	122	121	120	117	114	108	95	76		
XV-F 15-14	15	11	195	193	192	190	187	183	178	170	149	120		
XV-F 15-17	20	15	237	235	233	232	229	225	217	208	182	147		
XV-F 20-5	7,5	5,5	70	70	70	69	69	68	67	65	61	54	50	37
XV-F 20-7	10	7,5	102	101	100	99	97	96	95	93	86	76	69	54
XV-F 20-10	15	11	145	145	144	143	142	141	139	135	124	110	103	80
XV-F 20-14	20	15	204	204	203	202	200	198	195	190	176	156	145	113
XV-F 20-17	25	18,5	250	249	247	246	245	241	238	232	216	193	179	140

PARA OTRAS ESPECIFICACIONES CONSULTAR NUESTRO CATALOGO TECNICO DE EQUIPOS
CHECK OUR TECHNICAL CATALOGUE FOR MORE INFORMATION

EQUIPOS 1 BOMBA

1 PUMP BOOSTER SET

TIPO EQUIPO 1 BOMBA 1 PUMP BOOSTER SET TYPE	Potencia Total Equipo HP	Ø IMP.
EP 1 x XV-F 5-8	1,5	DN 32
EP 1 x XV-F 5-10	2	DN 32
EP 1 x XV-F 5-14	3	DN 32
EP 1 x XV-F 5-16	3	DN 32
EP 1 x XV-F 5-20	4	DN 32
EP 1 x XV-F 5-29	5,5	DN 32
EP 1 x XV-F 5-36	7,5	DN 32
EP 1 x XV-F 10-6	3	DN 40
EP 1 x XV-F 10-9	4	DN 40
EP 1 x XV-F 10-10	5,5	DN 40
EP 1 x XV-F 10-12	5,5	DN 40
EP 1 x XV-F 10-16	7,5	DN 40
EP 1 x XV-F 10-22	10	DN 40
EP 1 x XV-F 15-5	5,5	DN 50
EP 1 x XV-F 15-7	7,5	DN 50
EP 1 x XV-F 15-9	10	DN 50
EP 1 x XV-F 15-14	15	DN 50
EP 1 x XV-F 15-17	20	DN 50
EP 1 x XV-F 20-5	7,5	DN 50
EP 1 x XV-F 20-7	10	DN 50
EP 1 x XV-F 20-10	15	DN 50
EP 1 x XV-F 20-14	20	DN 50
EP 1 x XV-F 20-17	25	DN 50

EQUIPOS 2 BOMBA

2 PUMP BOOSTER SET

TIPO EQUIPO 2 BOMBA 2 PUMP BOOSTER SET TYPE	Potencia Total Equipo HP	Ø IMP.
EP 2 x XV-F 5-8	2 x 1,5	2 1/2"
EP 2 x XV-F 5-10	2 x 2	2 1/2"
EP 2 x XV-F 5-14	2 x 3	2 1/2"
EP 2 x XV-F 5-16	2 x 3	2 1/2"
EP 2 x XV-F 5-20	2 x 4	2 1/2"
EP 2 x XV-F 5-29	2 x 5,5	2 1/2"
EP 2 x XV-F 5-36	2 x 7,5	2 1/2"
EP 2 x XV-F 10-6	2 x 3	2 1/2"
EP 2 x XV-F 10-9	2 x 4	2 1/2"
EP 2 x XV-F 10-10	2 x 5,5	2 1/2"
EP 2 x XV-F 10-12	2 x 5,5	2 1/2"
EP 2 x XV-F 10-16	2 x 7,5	2 1/2"
EP 2 x XV-F 10-22	2 x 10	2 1/2"
EP 2 x XV-F 15-5	2 x 5,5	DN 100
EP 2 x XV-F 15-7	2 x 7,5	DN 100
EP 2 x XV-F 15-9	2 x 10	DN 100
EP 2 x XV-F 15-14	2 x 15	DN 100
EP 2 x XV-F 15-17	2 x 20	DN 100
EP 2 x XV-F 20-5	2 x 7,5	DN 100
EP 2 x XV-F 20-7	2 x 10	DN 100
EP 2 x XV-F 20-10	2 x 15	DN 100
EP 2 x XV-F 20-14	2 x 20	DN 100
EP 2 x XV-F 20-17	2 x 25	DN 100

EQUIPOS 3 BOMBA

3 PUMP BOOSTER SET

TIPO EQUIPO 3 BOMBA 3 PUMP BOOSTER SET TYPE	Potencia Total Equipo HP	Ø IMP.
EP 3 x XV-F 5-8	3 x 1,5	3"
EP 3 x XV-F 5-10	3 x 2	3"
EP 3 x XV-F 5-14	3 x 3	3"
EP 3 x XV-F 5-16	3 x 3	3"
EP 3 x XV-F 5-20	3 x 4	3"
EP 3 x XV-F 5-29	3 x 5,5	3"
EP 3 x XV-F 5-36	3 x 7,5	3"
EP 3 x XV-F 10-6	3 x 3	3"
EP 3 x XV-F 10-9	3 x 4	3"
EP 3 x XV-F 10-10	3 x 5,5	3"
EP 3 x XV-F 10-12	3 x 5,5	3"
EP 3 x XV-F 10-16	3 x 7,5	3"
EP 3 x XV-F 10-22	3 x 10	3"
EP 3 x XV-F 15-5	3 x 5,5	DN 100
EP 3 x XV-F 15-7	3 x 7,5	DN 100
EP 3 x XV-F 15-9	3 x 10	DN 100
EP 3 x XV-F 15-14	3 x 15	DN 100
EP 3 x XV-F 15-17	3 x 20	DN 100
EP 3 x XV-F 20-5	3 x 7,5	DN 125
EP 3 x XV-F 20-7	3 x 10	DN 125
EP 3 x XV-F 20-10	3 x 15	DN 125
EP 3 x XV-F 20-14	3 x 20	DN 125
EP 3 x XV-F 20-17	3 x 25	DN 125

PARA OTRAS ESPECIFICACIONES CONSULTAR NUESTRO CATALOGO TECNICO DE EQUIPOS
CHECK OUR TECHNICAL CATALOGUE FOR MORE INFORMATION

TIPO BOMBA PUMP TYPE	Potencia Bomba		CAUDAL TOTAL 3 BOMBAS / 3 PUMPS TOTAL FLOW													
			0	6	12	18	24	30	36	42	48	54	60	66	72	78
	Pump Power		CAUDAL TOTAL 2 BOMBAS / 2 PUMPS TOTAL FLOW													
			0	4	8	12	16	20	24	28	32	36	40	44	48	52
	HP	KW	CAUDAL TOTAL 1 BOMBA / 1 PUMPS TOTAL FLOW													
		0	2	4	6	8	10	12	14	16	18	20	22	24	26	
		ALTURA m.c.a. / HEIGHT w.c.m.														
K-10	1	0,75	44	38	29	14										
K-15	1,5	1,1	44	41	36	32	26	19								
K-17	1,5	1,1	53	49	40	24										
K-20	2	1,5	50	46,5	42	40	33	22								
K-25	2,5	1,8	62	58	48	34										
K-30	3	2,2	65	61	58	52	36									
K-31	3	2,2	39	38	37	35	34	32,5	31	29	27	25				
K-40	4	3	74	70,5	67	61	44									
K-41	4	3	44	42,5	41	40	39	37,5	36	34	32	30				
K-55	5,5	4	84	82	79	75	67	55								
K-56	5,5	4	56	55	54	52	51	49,5	48	46	44	42				
K-75	7,5	5,5	77	76	75	73	72	70,5	69	67	64	60	52	47	43	
K-100	10	7,35	97	95,5	94	93	92	90,5	89	86	84	82	78	74	69	
K-125	12,5	9,2	88	86,5	85	83	82	81	80	78	77	76	72	69	65	59
K-150	15	11	99	98	97	96	95	94,5	94	93	92	90	86	83	80	75
MN 32-200 C	5,5	4				40	38,9	37,8	37,5	37	35,6	34,2	33,2	31,6	30	26
MN 32-200 B	7,5	5,5				52	51,2	50,4	50	49	47,9	46,8	46	44,35	42,7	39,1
MN 32-200 A	10	7,5				60	59,5	59	58	58	57	56	54,7	3	51,5	48
MN 32-250 C	12,5	9,2				68,5	68	67	67	66	65	63,5	62,5	60,6	58,7	54
MN 32-250 B	15	11				81	80	80	79	79	78	77	76	74	72,6	69
MN 32-250 A	20	15				93	92	91,5	91	91	90,5	90	89	87	85,7	82,5

PARA OTRAS ESPECIFICACIONES CONSULTAR NUESTRO CATALOGO TECNICO DE EQUIPOS
CHECK OUR TECHNICAL CATALOGUE FOR MORE INFORMATION

EQUIPOS 1 BOMBA
1 PUMP BOOSTER SET

TIPO EQUIPO 1 BOMBA 1 PUMP BOOSTER SET TYPE	Potencia Total Equipo HP	Ø IMP.
EP 1xK-10	1	1"
EP 1xK-15	1,5	1"
EP 1xK-17	1,5	1"
EP 1xK-20	2	1"
EP 1xK-25	2,5	1"
EP 1xK-30	3	1"
EP 1xK-31	3	1 1/4"
EP 1xK-40	4	1"
EP 1xK-41	4	1 1/4"
EP 1xK-55	5,5	1"
EP 1xK-56	5,5	1"
EP 1xK-75	7,5	1 1/4"
EP 1xK-100	10	1 1/4"
EP 1xK-125	12,5	1 1/4"
EP 1xK-150	15	1 1/4"
EP 1xMN 32-200 C	5,5	1 1/4"
EP 1xMN 32-200 B	7,5	1 1/4"
EP 1xMN 32-200 A	10	1 1/4"
EP 1xMN 32-250 C	12,5	1 1/4"
EP 1xMN 32-250 B	15	1 1/4"
EP 1xMN 32-250 A	20	1 1/4"

EQUIPOS 2 BOMBA
2 PUMP BOOSTER SET

TIPO EQUIPO 2 BOMBA 2 PUMP BOOSTER SET TYPE	Potencia Total Equipo HP	Ø IMP.
EP 2xK-10	2x1	2"
EP 2xK-15	2x1,5	2"
EP 2xK-17	2x1,5	2"
EP 2xK-20	2x2	2"
EP 2xK-25	2x2,5	2"
EP 2xK-30	2x3	2"
EP 2xK-31	2x3	3"
EP 2xK-40	2x4	2"
EP 2xK-41	2x4	3"
EP 2xK-55	2x5,5	2"
EP 2xK-56	2x5,5	3"
EP 2xK-75	2x7,5	DN 100
EP 2xK-100	2x10	DN 100
EP 2xK-125	2x12,5	DN 100
EP 2xK-150	2x15	DN 100
EP 2xMN 32-200 C	2x5,5	DN 100
EP 2xMN 32-200 B	2x7,5	DN 100
EP 2xMN 32-200 A	2x10	DN 100
EP 2xMN 32-250 C	2x12,5	DN 100
EP 2xMN 32-250 B	2x15	DN 100
EP 2xMN 32-250 A	2x20	DN 100

EQUIPOS 3 BOMBA
3 PUMP BOOSTER SET

TIPO EQUIPO 3 BOMBA 3 PUMP BOOSTER SET TYPE	Potencia Total Equipo HP	Ø IMP.
EP 3xK-10	3x1	2 1/2"
EP 3xK-15	3x1,5	3"
EP 3xK-17	3x1,5	2 1/2"
EP 3xK-20	3x2	3"
EP 3xK-25	3x2,5	2 1/2"
EP 3xK-30	3x3	3"
EP 3xK-31	3x3	DN 100
EP 3xK-40	3x4	3"
EP 3xK-41	3x4	DN 100
EP 3xK-55	3x5,5	3"
EP 3xK-56	3x5,5	DN 100
EP 3xK-75	3x7,5	DN 125
EP 3xK-100	3x10	DN 125
EP 3xK-125	3x12,5	DN 125
EP 3xK-150	3x15	DN 125
EP 3xMN 32-200 C	3x5,5	DN 125
EP 3xMN 32-200 B	3x7,5	DN 125
EP 3xMN 32-200 A	3x10	DN 125
EP 3xMN 32-250 C	3x12,5	DN 125
EP 3xMN 32-250 B	3x15	DN 125
EP 3xMN 32-250 A	3x20	DN 125

PARA OTRAS ESPECIFICACIONES CONSULTAR NUESTRO CATALOGO TECNICO DE EQUIPOS
CHECK OUR TECHNICAL CATALOGUE FOR MORE INFORMATION



■ APLICACIONES:

Los equipos de bombeo automáticos descritos en el presente catalogo, son conjuntos diseñados para ofrecer la mejor solución para el suministro de agua a presión en una instalación de protección de incendios, por lo cual son especialmente apropiados para muy diversas instalaciones como pueden ser: edificios públicos y privados, grandes superficies comerciales, almacenes, naves industriales, etc... Nuestra línea de equipos aquí reflejados han sido estudiados para garantizar un funcionamiento fiable y duradero incluso en las condiciones mas extremas, condiciones que en este tipo de aplicaciones son bastante comunes.

SACI PUMPS como punto de partida en el diseño de estos equipos ha tenido en cuenta una serie de premisas básicas:

- Cumplimiento estricto de la normativa vigente **UNE 23-500-90**, la reciente **EN 12845** y las reglas técnicas editadas por **CEPREVEN**.
- Ofrecer una amplia gama de equipos, ya sea en tipo de ejecución, varias bombas principales eléctricas o diesel, normativas UNE, EN ó CEPREVEN y como no, en prestaciones de los mismos: hasta 288 m³/h de caudal nominal y hasta 120 m.c.a. de altura manométrica.
- Diseño compacto, robusto y totalmente preparado, cableado para su puesta en marcha definitiva en destino garantizando de esta forma una **FÁCIL INSTALACIÓN** y un **MÍNIMO MANTENIMIENTO PREVENTIVO**.

■ EJECUCIONES:

Podemos encontrar diferentes gamas de equipos contra incendios bien diferenciadas:

- 1) Equipos bajo normas **UNE 23-500-90** que dividimos en 4 líneas en función de tipo y nº de bombas principales que incorporan:
 - **U.E.** Equipos que incorporan 1 bomba principal eléctrica y 1 bomba jockey.
 - **U.E.E.** Equipos que incorporan 2 bombas principales eléctricas y 1 bomba jockey.
 - **U.D.** Equipos que incorporan 1 bomba principal Diesel y 1 bomba jockey.
 - **U.E.D.** Equipos que incorporan 1 bomba principal eléctrica, 1 bomba principal diesel y 1 bomba jockey.
- 2) Equipos bajo regla técnica **CEPREVEN RT2-ABA** que dividimos en 4 líneas en función de tipo y nº de bombas principales que incorporan:
 - **C.E.** Equipos que incorporan 1 bomba principal eléctrica y 1 bomba jockey.
 - **C.E.E.** Equipos que incorporan 2 bombas principales eléctricas y 1 bomba jockey.
 - **C.D.** Equipos que incorporan 1 bomba principal Diesel y 1 bomba jockey.
 - **C.E.D.** Equipos que incorporan 1 bomba principal eléctrica, 1 bomba principal diesel y 1 bomba jockey.
- 3) Equipos bajo normas **EN 12845** (norma de reciente aplicación y de ámbito europeo) que dividimos en 4 líneas en función de tipo y nº de bombas principales que incorporan:
 - **N.E.** Equipos que incorporan 1 bomba principal eléctrica y 1 bomba jockey.
 - **N.E.E.** Equipos que incorporan 2 bombas principales eléctricas y 1 bomba jockey.
 - **N.D.** Equipos que incorporan 1 bomba principal Diesel y 1 bomba jockey.
 - **N.E.D.** Equipos que incorporan 1 bomba principal eléctrica, 1 bomba principal diesel y 1 bomba jockey.

Bajo demanda podemos ofertar cualquier ejecución no reflejada en el presente catálogo, otros equipos con normas UNE 23-590-98 para rociadores, o bien equipos ECI, que son aquellos que están contruidos bajo unas especificaciones internas, para aquellas instalaciones donde no se requiera una normativa específica.

PARA OTRAS ESPECIFICACIONES CONSULTAR NUESTRO CATALOGO TECNICO DE EQUIPOS

■ APPLICATIONS:

The automatic pumping units described herein are designed to offer the best solution for pressurised water supply in a fire fighting installation, and are therefore particularly suitable for highly diverse installations such as: Public and private buildings, large commercial areas, Stores, Warehouses, etc.

Our line of units we reflect here has been studied to guarantee reliable, lasting working even in the most extreme conditions, conditions where these kinds of applications are quite common.

In commencing the design of these units, BOMBAS SACI has borne in mind a series of basic premises:

- Strict compliance with current UNE 23-500 regulations and all the technical rules published by CEPREVEN normally demanded by insurance companies.
- Offer a wide range of units either in execution, several electric or diesel main pumps, UNE or CEPREVEN standards, or in output: up to 288 m³/h nominal flow and up to 120 m.c.a manometric height.
- Compact design, robust and totally prepared, wired for final commissioning at destination, thus guaranteeing an **EASY INSTALLATION** and **MINIMAL PREVENTIVE MAINTENANCE**.

■ EXECUTIONS:

This catalogue presents 3 different ranges of fire fighting equipment.

1) Units under UNE 23-500-90 standards, which we divide into 4 working lines depending on type and number of main pumps they include:

- **U.E.** Units incorporating 1 main electric pump and 1 jockey pump.
- **U.E.E.** Units incorporating 2 main electric pumps and 1 jockey pump.
- **U.D.** Units incorporating 1 main diesel pump and 1 jockey pump.
- **U.E.D.** Units incorporating 1 main electric pump, 1 main diesel pump and 1 jockey pump.

2) Units under CEPREVEN RT2-ABA 96 standards, which we divide into 4 working lines depending on type and number of main pumps they include:

- **C.E.** Units incorporating 1 main electric pump and 1 jockey pump.
- **C.E.E.** Units incorporating 2 main electric pumps and 1 jockey pump.
- **C.D.** Units incorporating 1 main diesel pump and 1 jockey pump.
- **C.E.D.** Units incorporating 1 main electric pump, 1 main diesel pump and 1 jockey pump.

3) Units under EN 12845 standards, which we divide into 4 working lines depending on type and number of main pumps they include:

- **N.E.** Units incorporating 1 main electric pump and 1 jockey pump.
- **N.E.E.** Units incorporating 2 main electric pumps and 1 jockey pump.
- **N.D.** Units incorporating 1 main diesel pump and 1 jockey pump.
- **N.E.D.** Units incorporating 1 main electric pump, 1 main diesel pump and 1 jockey pump.

On demand we can offer any kind of execution not reflected in this catalogue, other units with UNE 23-590-98 standards (Sprinklers, very close to the CEPREVEN), or ECI units, which are those built in accordance with internal specifications for installations not requiring specific regulations.

All the units reflected in the tables are prepared for working with loading suction, otherwise specify on the order.

Optional accessories FLOW METERS.

CHECK OUR TECHNICAL CATALOGUE FOR MORE INFORMATION

■ FUNCIONAMIENTO DE UN EQUIPO CONTRA INCENDIOS:

La bomba Jockey es la encargada de mantener la red presurizada, compensando las posibles fugas de la instalación. En caso de iniciarse un incendio y comenzar a abrirse puntos de consumo, la presión va disminuyendo hasta el punto en que se pone en marcha la bomba de caudal o principal.

En cuanto a la bomba principal, además de cumplir con el punto nominal de trabajo, debe cumplir las siguientes especificaciones:

- A caudal cero, la presión no será superior al 130% de la presión nominal.
- A caudal 140% del nominal, la presión no será inferior al 70% de la presión nominal.
- El motor debe dimensionarse para cumplir el punto del 140% del caudal nominal.

LAS BOMBAS PRINCIPALES SEGÚN NORMATIVA DEBEN ARRANCAR AUTOMÁTICAMENTE, PERO EL PARO DE LAS MISMAS DEBE SER OBLIGATORIAMENTE MANUAL.

■ CARACTERÍSTICAS CONSTRUCTIVAS:

Equipos compuestos por:

- Bomba centrífuga principal o de caudal, monobloc o sobrecargada (eléctrica o diesel).
- Bomba Jockey o auxiliar (eléctrica).
- Colector de impulsión completo (válvulas de bola y retención).
- Bancada general y soporte cuadro eléctrico.
- Acumulador, presostatos, manómetro de glicerina.
- Cuadro eléctrico de mando y protección del equipo en armario metálico con grado de protección IP-54, y según normativas aplicadas.
- Resto accesorios según tipo de normas.

Bajo demanda colector de pruebas equipado con caudalímetro.

Todos los equipos reflejados en las tablas son para trabajar con aspiración en carga, en caso contrario especificar en la solicitud de pedido.

■ COLECTORES DE PRUEBAS (Opcional bajo demanda):

BOMBAS SACI les ofrece 2 sistemas de medición de caudal para equipos contra incendios:

• **Medición Proporcional por tubo + flotador:**

Compuesto por Medidor de metacrilato de lectura directa con escala en Lts/min. y un pequeño flotador en AISI 316 + un tramo de tubo embridado lateralmente con unas dimensiones mínimas de 10 DN antes del medidor y 5 DN después de él. Exclusivamente para su utilización con tubería HORIZONTAL.



	DN 40	DN 50	DN 65	DN 80	DN 100	DN 150	DN 200
CAUDAL MIN.	5	9	15	18	30	54	108
CAUDAL MAX.	23	33	54	69	120	234	432

• **Medición por presión diferencial y disco de medida:**

Compuesto por Rotámetro (medidor) de cristal o metálico con flotador, disco de aforo + dos tramos de tubo embridados lateralmente con unas dimensiones mínimas de 10 DN antes del medidor y 5 DN después de él. Para su utilización con tubería HORIZONTAL o Vertical. El caudal que circula por el rotámetro es proporcional a la raíz cuadrada de la presión diferencial, que a su vez es proporcional al cuadrado del caudal principal.



	DN 65	DN 80	DN 100	DN 125	DN 150	DN 200	DN 250
CAUDAL MAX.	49	72	124	190	260	460	750

TODOS LOS EQUIPOS REFLEJADOS EN LAS TABLAS VIENEN PREPARADOS PARA TRABAJAR CON ASPIRACIÓN EN CARGA, EN CASO CONTRARIO, ESPECIFICAR EN LA SOLICITUD DE PEDIDO.

PARA OTRAS ESPECIFICACIONES CONSULTAR NUESTRO CATALOGO TECNICO DE EQUIPOS

■ WORKING PRINCIPLE OF FIRE FIGHTING UNITS:

MAIN PUMPS:

The main pump supplies the flow and pressure required by the system. It must be capable of driving at least 140% of the nominal flow at a pressure not below 70% of the nominal pressure. The motors of the main pumps must be sized for the maximum absorbed power of the pump at the overload point plus a safety margin.

Main pumps could be with electric motor or with diesel engine:

THE MAIN PUMPS, ACCORDING TO REGULATIONS, MUST START AUTOMATICALLY, BUT WILL NECESSARILY BE STOPPED MANUALLY.

JOCKEY" AUXILIARY PUMP

Multicellular vertical or horizontal pump with electric motor that keeps the lines pressurised and compensates possible leaks from the installation and preventing the main pump from starting due to a small leak.

The jockey pump STARTS AND STOPS AUTOMATICALLY through a signal from a pressure gauge.

■ OTHER COMPONENTS:

- Drive Collector: Sized for a maximum water speed of 3 m/s
- General Bench of the unit: In folded plate with a minimum thickness of 6 mm for small units and laminate profile for larger units, sized to offer great robustness.
- Non return valves: Calculated to achieve a minimal load loss.
- Close Valves: Butterfly type for sizes from 3" and Ball type for smaller sizes.
- Safety valves: Driven exhaust located on the drive unit of the main pumps under the retention valves and alongside the start failure pressure gauge, these must be calibrated to a pressure somewhat below the maximum for the pump and protect it from damage caused by zero flow.
- Pressure gauges: High quality, one is used for the start of each main pump, another for starting and stopping the jockey pump and another on the drive of each main pump next to the safety valve to make sure there is pressure with the pump running.
- start and control electrical control panel for electrical and diesel pumps according to the regulations.

OPTIONAL ELEMENTS UNDER DEMAND

All of our units may be personalised with a series of optional elements, such as suction collectors, non vibration sleeves. Our technical department will inform you of the prices and possibilities of these accessories.

■ TEST COLLECTORS (Optional on demand):

BOMBAS SACI offers 2 flow measuring systems for fire fighting equipment:

- Proportional Measurement by pipe + float:

Comprising a methacryllate measurer with direct reading and scale in l/min. and a small AISI 316 float + a section of side-flanged pipe with minimum dimensions of 10 DN before the measurer and 5 DN following it. Exclusively for use with HORIZONTAL piping.

- Measurement by differential pressure and measurement disk:

Comprising a glass or metal Rotametre (measurer) with a float, calibrated disk + two sections of side-flanged pipe with minimum dimensions of 10 DN before the measurer and 5 DN following it. Exclusively for use with HORIZONTAL or Vertical piping.

The flow circulating through the rotametre is proportional to the square root of the differential pressure, which in turn is proportional to the square of the main flow.



	DN 40	DN 50	DN 65	DN 80	DN 100	DN 150	DN 200
MIN. FLOW	5	9	15	18	30	54	108
MAX. FLOW	23	33	54	69	120	234	432



	DN 65	DN 80	DN 100	DN 125	DN 150	DN 200	DN 250
MAX. FLOW	49	72	124	190	260	460	750

CHECK OUR TECHNICAL CATALOGUE FOR MORE INFORMATION

UNE 23-500-90

TIPO EQUIPO <i>SET TYPE</i>	POTENCIA HP		CAUDAL NOMINAL m³/h / <i>Nominal Flow m³/h</i> Caudal de sobrecarga m³/h / <i>Overload flow m³/h</i>													
	PRAL. ELEC.	JOCKEY	12	18	24	30	36	42	48	60	72	84	96	108		
			17	25	34	42	50	59	67	84	101	118	134	151		
ALTURA NOMINAL m.c.a. / <i>Nominal Height w.c.m.</i> Altura de sobrecarga m.c.a. / <i>Overload height w.c.m.</i>																
U.E. / 404	3	1,1	36 26												U.E.	
U.E. / 405	4	1,3	46 34													
U.E. / 406	4	1,3	56 42													
U.E. / 407	5,5	2	65 51													
U.E. / 163-5	7,5	3	72 63													
U.E. / 75	7,5	3	69 65	60 43												
U.E. / 100	10	4	89 85	82 69												
U.E. / 150	15	4	94 91	90 78												
U.E. / 420 B	7,5	1,7	46 42	43 37												
U.E. / 420 A	10	1,7	58 55	56 50	53 44											
U.E. / 425 B	15	3		70 65	67 56											
U.E. / 425 A	20	4		87 82	84 76											
U.E. / 520 C	12,5	1,7				43 37	40 34	39 28								
U.E. / 520 B	15	1,7				49 43	47 40	45 34								
U.E. / 520 A	20	2				56 52	55 50	53 46								
U.E. / 525 C	20	3				69 63	68 62	66 58								
U.E. / 525 B	25	3				76 71	75 69	73 65								
U.E. / 525 A	30	4				88 83	86 81	85 77								
U.E. / 616 A	20	1,5							40 39	40 37	39 35	38 32				
U.E. / 652 C	20	1,5							45 42	44 39	42 36	41 32				
U.E. / 652 B	25	2							50 47	49 44	47 42	46 38				
U.E. / 652 A	30	2							57 55	56 52	55 50	53 47				
U.E. / 525 S23-30	30	3							67 56	62 48						
U.E. / 525 S24-40	40	3							74 65	70 55						
U.E. / 525 S25-40	40	4							82 72	78 63						
U.E. / 525 S26-40	40	4				94 94	94 92	93 90	90 88	88 82						
U.E. / 652 S21-40	40	2											59 55	57 50	55 43	
U.E. / 652 S22-40	40	3											66 62	64 58	62 53	
U.E. / 625 S24-50	50	3											71 64	70 60	66 50	
U.E. / 625 S25-50	50	3											80 71	78 67	73 60	
U.E. / 625 S26-60	60	4											92 87	91 82	89 80	87 73

PARA OTRAS ESPECIFICACIONES CONSULTAR NUESTRO CATALOGO TECNICO DE EQUIPOS
CHECK OUR TECHNICAL CATALOGUE FOR MORE INFORMATION

UNE 23-500-90

TIPO EQUIPO SET TYPE	POTENCIA HP			CAUDAL NOMINAL m³/h / Nominal Flow m³/h Caudal de sobrecarga m³/h / Overload flow m³/h												
	PRAL. ELEC.	AUX. ELEC.	JOCKEY	12	18	24	30	36	42	48	60	72	84	96	108	
				17	25	34	42	50	59	67	84	101	118	134	151	
ALTURA NOMINAL m.c.a. / Nominal Height w.c.m. Altura de sobrecarga m.c.a. / Overload height w.c.m.																
U.E.E. / 404	3	3	1,1	36 26												
U.E.E. / 405	4	4	1,3	46 34												
U.E.E. / 406	4	4	1,3	56 42												
U.E.E. / 407	5,5	5,5	2	65 51												
U.E.E. / 163-5	7,5	7,5	3	72 63												
U.E.E. / 75	7,5	7,5	3	69 65	60 43											
U.E.E. / 100	10	10	4	89 85	82 69											
U.E.E. / 150	15	15	4	94 91	90 78											
U.E.E. / 420 B	7,5	7,5	1,7	46 42	43 37											
U.E.E. / 420 A	10	10	1,7	58 55	56 50	53 44										
U.E.E. / 425 B	15	15	3		70 65	67 56										
U.E.E. / 425 A	20	20	4		87 82	84 76										
U.E.E. / 520 C	12,5	12,5	1,7				43 37	40 34	39 28							
U.E.E. / 520 B	15	15	1,7				49 43	47 40	45 34							
U.E.E. / 520 A	20	20	2				56 52	55 50	53 46							
U.E.E. / 525 C	20	20	3				69 63	68 62	66 58							
U.E.E. / 525 B	25	25	3				76 71	75 69	73 65							
U.E.E. / 525 A	30	30	4				88 83	86 81	85 77							
U.E.E. / 616 A	20	20	1,5							40 39	40 37	39 35	38 32			
U.E.E. / 652 C	20	20	1,5							45 42	44 39	42 36	41 32			
U.E.E. / 652 B	25	25	2							50 47	49 44	47 42	46 38			
U.E.E. / 652 A	30	30	2							57 55	56 52	55 50	53 47			
U.E.E. / 525 S23-30	30	30	3							67 56	62 48					
U.E.E. / 525 S24-40	40	40	3							74 65	70 55					
U.E.E. / 525 S25-40	40	40	4							82 72	78 63					
U.E.E. / 525 S26-40	40	40	4				94 94	94 92	93 90	90 88	88 82					
U.E.E. / 652 S21-40	40	40	2										59 55	57 50	55 43	
U.E.E. / 652 S22-40	40	40	3										66 62	64 58	62 53	
U.E.E. / 625 S24-50	50	50	3										71 64	70 60	66 50	
U.E.E. / 625 S25-50	50	50	3										80 71	78 67	73 60	
U.E.E. / 625 S26-60	60	60	4										92 87	91 82	89 80	87 73

U.E.E.

PARA OTRAS ESPECIFICACIONES CONSULTAR NUESTRO CATALOGO TECNICO DE EQUIPOS
CHECK OUR TECHNICAL CATALOGUE FOR MORE INFORMATION

UNE 23-500-90

TIPO EQUIPO SET TYPE	POTENCIA HP		CAUDAL NOMINAL m ³ /h / Nominal Flow m ³ /h Caudal de sobrecarga m ³ /h / Overload flow m ³ /h												
	AUX. DIESEL	JOCKEY	12	18	24	30	36	42	48	60	72	84	96	108	
			17	25	34	42	50	59	67	84	101	118	134	151	
ALTURA NOMINAL m.c.a. / Nominal Height w.c.m. Altura de sobrecarga m.c.a. / Overload height w.c.m.															
U.D. / 404	7,6	1,1	36 26												
U.D. / 405	7,6	1,3	46 34												
U.D. / 406	7,6	1,3	56 42												
U.D. / 407	10,3	2	65 51												
U.D. / 163-5	10,3	3	72 63												
U.D. / 75	10,3	3	69 65	60 43											
U.D. / 100	14	4	89 85	82 69											
U.D. / 150	24	4	94 91	90 78											
U.D. / 420 B	7,6	1,7	46 42	43 37											
U.D. / 420 A	10,3	1,7	58 55	56 50	53 44										
U.D. / 425 B	17,6	3		70 65	67 56										
U.D. / 425 A	24	4		87 82	84 76										
U.D. / 520 C	11,5	1,7				43 37	40 34	39 28							
U.D. / 520 B	11,5	1,7				49 43	47 40	45 34							
U.D. / 520 A	17,6	2				56 52	55 50	53 46							
U.D. / 525 C	24	3				69 63	68 62	66 58							
U.D. / 525 B	24	3				76 71	75 69	73 65							
U.D. / 525 A	24	4				88 83	86 81	85 77							
U.D. / 616 A	24	1,5							40 39	40 37	39 35	38 32			
U.D. / 652 C	24	1,5							45 42	44 39	42 36	41 32			
U.D. / 652 B	24	2							50 47	49 44	47 42	46 38			
U.D. / 652 A	24	2							57 55	56 52	55 50	53 47			
U.D. / 525 S23-30	39	3							67 56	62 48					
U.D. / 525 S24-40	39	3							74 65	70 55					
U.D. / 525 S25-40	39	4							82 72	78 63					
U.D. / 525 S26-40	39	4				94 94	94 92	93 88	90 82	88 71					
U.D. / 652 S21-40	39	2											59 55	57 50	55 43
U.D. / 652 S22-40	39	3											66 62	64 58	62 53
U.D. / 625 S24-50	64	3											71 64	70 60	66 50
U.D. / 625 S25-50	64	3											80 71	78 67	73 60
U.D. / 625 S26-60	64	4											92 87	91 82	89 80

U.D.

PARA OTRAS ESPECIFICACIONES CONSULTAR NUESTRO CATALOGO TECNICO DE EQUIPOS
CHECK OUR TECHNICAL CATALOGUE FOR MORE INFORMATION

UNE 23-500-90

TIPO EQUIPO SET TYPE	POTENCIA HP			CAUDAL NOMINAL m³/h / Nominal Flow m³/h Caudal de sobrecarga m³/h / Overload flow m³/h												
	PRAL. ELEC.	AUX. DIESEL.	JOCKEY	12	18	24	30	36	42	48	60	72	84	96	108	
				17	25	34	42	50	59	67	84	101	118	134	151	
ALTURA NOMINAL m.c.a. / Nominal Height w.c.m. Altura de sobrecarga m.c.a. / Overload height w.c.m.																
U.E.D. / 404	3	7,6	1,1	36 26												
U.E.D. / 405	4	7,6	1,3	46 34												
U.E.D. / 406	4	7,6	1,3	56 42												
U.E.D. / 407	5,5	10,3	2	65 51												
U.E.D. / 163-5	7,5	10,3	3	72 63												
U.E.D. / 75	7,5	10,3	3	69 65	60 43											
U.E.D. / 100	10	14	4	89 85	82 69											
U.E.D. / 150	15	24	4	94 91	90 78											
U.E.D. / 420 B	7,5	7,6	1,7	46 42	43 37											
U.E.D. / 420 A	10	10,3	1,7	58 55	56 50	53 44										
U.E.D. / 425 B	15	17,6	3		70 65	67 56										
U.E.D. / 425 A	20	24	4		87 82	84 76										
U.E.D. / 520 C	12,5	11,5	1,7				43 37	40 34	39 28							
U.E.D. / 520 B	15	11,5	1,7				49 43	47 40	45 34							
U.E.D. / 520 A	20	17,6	2				56 52	55 50	53 46							
U.E.D. / 525 C	20	24	3				69 63	68 62	66 58							
U.E.D. / 525 B	25	24	3				76 71	75 69	73 65							
U.E.D. / 525 A	30	24	4				88 83	86 81	85 77							
U.E.D. / 616 A	20	24	1,5							40 39	40 37	39 35	38 32			
U.E.D. / 652 C	20	24	1,5							45 42	44 39	42 36	41 32			
U.E.D. / 652 B	25	24	2							50 47	49 44	47 42	46 38			
U.E.D. / 652 A	30	24	2							57 55	56 52	55 50	53 47			
U.E.D. / 525 S23-30	30	39	3							67 56	62 48					
U.E.D. / 525 S24-40	40	39	3							74 65	70 55					
U.E.D. / 525 S25-40	40	39	4							82 72	78 63					
U.E.D. / 525 S26-40	40	39	4				94 94	94 92	93 90	90 88	88 82					
U.E.D. / 652 S21-40	40	39	2										59 55	57 50	55 43	
U.E.D. / 652 S22-40	40	39	3										66 62	64 58	62 53	
U.E.D. / 625 S24-50	50	64	3										71 64	70 60	66 50	
U.E.D. / 625 S25-50	50	64	3										80 71	78 67	73 60	
U.E.D. / 625 S26-60	60	64	4										92 87	91 82	89 80	87 73

U.E.D.

PARA OTRAS ESPECIFICACIONES CONSULTAR NUESTRO CATALOGO TECNICO DE EQUIPOS
CHECK OUR TECHNICAL CATALOGUE FOR MORE INFORMATION

CEPREVEN RT2-ABA

TIPO EQUIPO SET TYPE	POTENCIA HP		CAUDAL NOMINAL m ³ /h / Nominal Flow m ³ /h Caudal de sobrecarga m ³ /h / Overload flow m ³ /h											
	PRAL. ELEC.	JOCKEY	12	18	24	30	36	42	48	60	72	84	96	108
			17	25	34	42	50	59	67	84	101	118	134	151
			ALTURA NOMINAL m.c.a. / Nominal Height w.c.m. Altura de sobrecarga m.c.a. / Overload height w.c.m.											
C.E. / 316 S 17 / 7,5	7,5	2	42 41	41 33	38 32									
C.E. / 320 S 20 / 10	10	2	50 49	48 44	45 38	42 30								
C.E. / 320 S 22 / 15	15	3	63 62	62 58	59 54	57 47	53 37							
C.E. / 325 S 23 / 15	15	3	78 76	77 73										
C.E. / 325 S 25 / 20	20	4	89 86	87 84										
C.E. / 325 S 26 / 25	25	3	101 97	98 93	94 78									
C.E. / 425 S 24 / 20	20	3			76 72	75 68								
C.E. / 425 S 25 / 25	25	3			82 81	81 80								
C.E. / 420 S 22 / 20	20	3					59 54	57 50	55 45					
C.E. / 425 S 23 / 25	25	3					66 60	64 55	61 51					
C.E. / 425 S 25 / 30	30	3					80 74	78 69	76 66					
C.E. / 425 S 26 / 30	30	4				90 87	89 83	87 78	84 74					
C.E. / 525 S 22 / 30	30	3								60 50	55 40			
C.E. / 525 S 23 / 30	30	3								67 56	62 48			
C.E. / 525 S 24 / 40	40	3								74 65	70 55			
C.E. / 525 S 25 / 40	40	3								82 72	78 63			
C.E. / 525 S 26 / 40	40	4						94 90	93 88	90 82	88 71			
C.E. / 652 S 20 / 30	30	3										53 48	51 42	49 35
C.E. / 652 S 21 / 40	40	3										59 55	57 50	55 43
C.E. / 652 S 22 / 40	40	3										66 62	64 58	62 53
C.E. / 625 S 24 / 50	50	3										71 64	70 60	66 50
C.E. / 625 S 25 / 50	50	3										80 71	78 67	73 60
C.E. / 625 S 26 / 60	60	4										92 87	91 82	89 80

C.E.

PARA OTRAS ESPECIFICACIONES CONSULTAR NUESTRO CATALOGO TECNICO DE EQUIPOS

CEPREVEN RT2-ABA

TIPO EQUIPO SET TYPE	POTENCIA HP			CAUDAL NOMINAL m³/h / Nominal Flow m³/h Caudal de sobrecarga m³/h / Overload flow m³/h												
	PRAL. ELEC. 1	PRAL. ELEC. 2	JOCKEY	12	18	24	30	36	42	48	60	72	84	96	108	
				17	25	34	42	50	59	67	84	101	118	134	151	
				ALTURA NOMINAL m.c.a. / Nominal Height w.c.m. Altura de sobrecarga m.c.a. / Overload height w.c.m.												
C.E.E. / 316 S 17 / 75	7,5	7,5	2	42 41	41 33	38 32										
C.E.E. / 320 S 20 / 10	10	10	2	50 49	48 44	45 38	42 30									
C.E.E. / 320 S 22 / 15	15	15	3	63 62	62 58	59 54	57 47	53 37								
C.E.E. / 325 S 23 / 15	15	15	3	78 76	77 73											
C.E.E. / 325 S 25 / 20	20	20	4	89 86	87 84											
C.E.E. / 325 S 26 / 25	25	25	3	101 97	98 93	94 78										
C.E.E. / 425 S 24 / 20	20	20	3			76 72	75 68									
C.E.E. / 425 S 25 / 25	25	25	3			82 81	81 80									
C.E.E. / 420 S 22 / 20	20	20	3					59 54	57 50	55 45						
C.E.E. / 425 S 23 / 25	25	25	3					66 60	64 55	61 51						
C.E.E. / 425 S 25 / 30	30	30	3					80 74	78 69	76 66						
C.E.E. / 425 S 26 / 30	30	30	4				90 87	89 83	87 78	84 74						
C.E.E. / 525 S 22 / 30	30	30	3								60 50	55 40				
C.E.E. / 525 S 23 / 30	30	30	3								67 56	62 48				
C.E.E. / 525 S 24 / 40	40	40	3								74 65	70 55				
C.E.E. / 525 S 25 / 40	40	40	3								82 72	78 63				
C.E.E. / 525 S 26 / 40	40	40	4						94 90	93 88	90 82	88 71				
C.E.E. / 652 S 20 / 30	30	30	3										53 48	51 42	49 35	
C.E.E. / 652 S 21 / 40	40	40	3										59 55	57 50	55 43	
C.E.E. / 652 S 22 / 40	40	40	3										66 62	64 58	62 53	
C.E.E. / 625 S 24 / 50	50	50	3										71 64	70 60	66 50	
C.E.E. / 625 S 25 / 50	50	50	3										80 71	78 67	73 60	
C.E.E. / 625 S 26 / 60	60	60	4										92 87	91 82	89 80	87 73

C.E.E.

CEPREVEN RT2-ABA

TIPO EQUIPO SET TYPE	POTENCIA HP		CAUDAL NOMINAL m³/h / Nominal Flow m³/h Caudal de sobrecarga m³/h / Overload flow m³/h												
	PRAL. DIESEL	JOCKEY	12	18	24	30	36	42	48	60	72	84	96	108	
			17	25	34	42	50	59	67	84	101	118	134	151	
ALTURA NOMINAL m.c.a. / Nominal Height w.c.m. Altura de sobrecarga m.c.a. / Overload height w.c.m.															
C.D. / 316 S 17 / 75	8	2	42 41	41 33	38 32										
C.D. / 320 S 20 / 10	11,5	2	50 49	48 44	45 38	42 30									
C.D. / 320 S 22 / 15	23,4	3	63 62	62 58	59 54	57 47	53 37								
C.D. / 325 S 23 / 15	23,4	3	78 76	77 73											
C.D. / 325 S 25 / 20	23,4	4	89 86	87 84											
C.D. / 325 S 26 / 25	23,4	3	101 97	98 93	94 78										
C.D. / 425 S 24 / 20	23,4	3			76 72	75 68									
C.D. / 425 S 25 / 25	23,4	3			82 81	81 80									
C.D. / 420 S 22 / 20	23,4	3					59 54	57 50	55 45						
C.D. / 425 S 23 / 25	23,4	3					66 60	64 55	61 51						
C.D. / 425 S 25 / 30	28,6	3					80 74	78 69	76 66						
C.D. / 425 S 26 / 30	28,6	4				90 87	89 83	87 78	84 74						
C.D. / 525 S 22 / 30	28,6	3								60 50	55 40				
C.D. / 525 S 23 / 30	28,6	3								67 56	62 48				
C.D. / 525 S 24 / 40	44	3								74 65	70 55				
C.D. / 525 S 25 / 40	44	3								82 72	78 63				
C.D. / 525 S 26 / 40	44	4						94 90	93 88	90 82	88 71				
C.D. / 652 S 20 / 30	44	3										53 48	51 42	49 35	
C.D. / 652 S 21 / 40	44	3										59 55	57 50	55 43	
C.D. / 652 S 22 / 40	44	3										66 62	64 58	62 53	
C.D. / 625 S 24 / 50	65	3										71 64	70 60	66 50	
C.D. / 625 S 25 / 50	65	3										80 71	78 67	73 60	
C.D. / 625 S 26 / 60	65	4										92 87	91 82	89 80	87 73

C.D.

PARA OTRAS ESPECIFICACIONES CONSULTAR NUESTRO CATALOGO TECNICO DE EQUIPOS

CEPREVEN RT2-ABA

TIPO EQUIPO SET TYPE	POTENCIA HP			CAUDAL NOMINAL m³/h / Nominal Flow m³/h Caudal de sobrecarga m³/h / Overload flow m³/h												
	PRAL. ELEC.	PRAL. DIESEL	JOCKEY	12	18	24	30	36	42	48	60	72	84	96	108	
				17	25	34	42	50	59	67	84	101	118	134	151	
ALTURA NOMINAL m.c.a. / Nominal Height w.c.m. Altura de sobrecarga m.c.a. / Overload height w.c.m.																
C.E.D. / 316 S 17 / 75	7,5	8	2	42 41	41 33	38 32										
C.E.D. / 320 S 20 / 10	10	11,5	2	50 49	48 44	45 38	42 30									
C.E.D. / 320 S 22 / 15	15	23,4	3	63 62	62 58	59 54	57 47	53 37								
C.E.D. / 325 S 23 / 15	15	23,4	3	78 76	77 73											
C.E.D. / 325 S 25 / 20	20	23,4	4	89 86	87 84											
C.E.D. / 325 S 26 / 25	25	23,4	3	101 97	98 93	94 78										
C.E.D. / 425 S 24 / 20	20	23,4	3			76 72	75 68									
C.E.D. / 425 S 25 / 25	25	23,4	3			82 81	81 80									
C.E.D. / 420 S 22 / 20	20	23,4	3					59 54	57 50	55 45						
C.E.D. / 425 S 23 / 25	25	23,4	3					66 60	64 55	61 51						
C.E.D. / 425 S 25 / 30	30	28,6	3					80 74	78 69	76 66						
C.E.D. / 425 S 26 / 30	30	28,6	4				90 87	89 83	87 78	84 74						
C.E.D. / 525 S 22 / 30	30	28,6	3								60 50	55 40				
C.E.D. / 525 S 23 / 30	30	28,6	3								67 56	62 48				
C.E.D. / 525 S 24 / 40	40	44	3								74 65	70 55				
C.E.D. / 525 S 25 / 40	40	44	3								82 72	78 63				
C.E.D. / 525 S 26 / 40	40	44	4						94 90	93 88	90 82	88 71				
C.E.D. / 652 S 20 / 30	30	44	3										53 48	51 42	49 35	
C.E.D. / 652 S 21 / 40	40	44	3										59 55	57 50	55 43	
C.E.D. / 652 S 22 / 40	40	44	3										66 62	64 58	62 53	
C.E.D. / 625 S 24 / 50	50	65	3										71 64	70 60	66 50	
C.E.D. / 625 S 25 / 50	50	65	3										80 71	78 67	73 60	
C.E.D. / 625 S 26 / 60	60	65	4										92 87	91 82	89 80	87 73

C.E.D.



PARA OTRAS ESPECIFICACIONES CONSULTAR NUESTRO CATALOGO TECNICO DE EQUIPOS



■ CUADROS ELECTRICOS PARA EQUIPOS DE PRESION Y BOMBAS DE AGUAS FECALES

■ Tensiones:

230 V monofásico (hasta 3 CV), 230 V trifásico (hasta 20 CV), 400 V trifásico, voltajes especiales (50-60 Hz)

■ Características generales:

Armario	Poliéster 1 y 2 bombas en potencias inferiores a 7,5 cv. Metálico en todo el resto de gama
Interruptor general	En todos los equipos de 1 y 2 bombas con potencias superiores a 7,5 cv. De serie en equipos de 3 y 4 bombas
Indicadores	Piloto verde de bomba en marcha. Piloto rojo de disparo por sobrecarga Piloto amarillo de alarma sobrenivel (sólo para fecales)
Mando	Selector de 3 posiciones MANUAL - PARO - AUTOMÁTICO por bomba
Protecciones	Guardamotor para bombas hasta 15 cv (disyuntor magnetotérmico) Fusibles y relés térmicos para potencias superiores
Accionamiento	Arranque directo con un contactor para bombas inferiores a 7,5 cv. Arranque estrella triángulo para potencias superiores a 5,5 cv.
Alternancia	2 bombas - Alternancia de las dos. 3 bombas - Alternancia de la 1ª - 3ª. 4 bombas - Alternancia de la 1ª - 2ª y 3ª - 4ª
Maniobra	230 Voltios
Alarma	En los equipos para aguas fecales salida de tensión para claxon externo de alarma de nivel.

■ Opciones:

Maniobra 24 voltios	En todos los equipos de presión y aguas fecales.
Alternancia 3-4 bombas	Alternancia de todas
Armario metálico	En los equipos de 1 y 2 bombas inferiores a 7,5 cv
Interruptor general	En los equipos de 1 y 2 bombas inferiores a 7,5 cv.
Interruptor horario	En los equipos de presión para accionar electroválvula.
Claxon	En los equipos de aguas fecales, claxon en la puerta de alarma de nivel.
Maniobra	En equipos de aguas fecales, boyas independientes de paro para cada bomba

■ Funcionamiento:

Cuadros para equipos de presión:

Materiales periféricos: Presostatos de trabajo y boya de paro nivel (o presostato inversado en bombeos desde la red general).
En manual funciona de forma continuada (sin atender a la presión de impulsión) y solo se para por la boya de paro o por disparo térmico.

En automático conserva las mismas condiciones que en manual, pero el funcionamiento está condicionado a los presostatos de trabajo; estos deben estar regulados en cascada. En equipos de más de una bomba, se alterna el arranque de las bombas.

Cuadros para bombas de aguas fecales:

Material periférico: Boyas de marcha, paro, sobrenivel y claxon exterior de alarma sobrenivel.

En manual el funcionamiento es continuado y solo se para por la boya de paro o por sobrecarga de la bomba.

En automático conserva las mismas condiciones que en manual, pero el orden de marcha se efectúa por las boyas. En equipos de más de una bomba, se alterna el arranque de las bombas. La boya de alarma nivel acciona un claxon exterior, (bajo demanda se puede instalar en el propio cuadro). La boya de nivel mínimo es para todas las bombas, (bajo demanda se pueden colocar boyas de paro independientes para cada bomba).



■ CUADROS ELECTRICOS PARA EQUIPOS DE PRESION Y BOMBAS DE AGUAS FECALES CON ARRANCADOR PROGRESIVO

■ Tensiones:

400 V trifásico, voltajes especiales (50-60 Hz). Todos los cuadros para todas las potencias.

■ Características generales:

Armario	Metálico para todas las potencias
Interruptor general	De serie en todos los cuadros
Indicadores	Piloto verde de bomba en marcha. Piloto rojo de disparo por sobrecarga Piloto amarillo de alarma sobrenivel (sólo para fecales)
Mando	Selector de 3 posiciones MANUAL - PARO - AUTOMÁTICO por bomba
Protecciones	Guardamotor para bombas hasta 15 cv (disyuntor magnetotérmico) Fusibles y relés térmicos para potencias superiores
Accionamiento	Arranque directo (3 hilos) por arrancador suave Arranque a 6 hilos por arrancador suave (bajo demanda)
Alternancia	2 bombas - Alternancia de las dos. 3 bombas - Alternancia de la 1ª - 3ª. 4 bombas - Alternancia de la 1ª - 2ª y 3ª - 4ª
Maniobra	230 Voltios y protegida con fusibles
Alarma	Los cuadros para bombas de aguas fcales disponen de una salida de tensión (230Vac) para un claxon externo de alarma de nivel
Conexionado	Borneo marcado y en posición elevada e inclinada para una fácil conexión de los elementos

■ Opciones:

Maniobra 24 voltios	En todos los equipos
Alternancia 3 bombas	Alternancia de todas
Interruptor horario	En los equipos de presión para accionar electroválvula.
Claxon	En los equipos de aguas fecales, claxon en la puerta de alarma de nivel.
Maniobra	Cualquier tipo de maniobra especial
Sondas	Sondas pozo o depósito o, sondas pozo y depósito para equipos de presión

■ Funcionamiento:

Cuadros para equipos de presión:

Materiales periféricos: Presostatos de trabajo y boya de paro nivel o sondas (si se han solicitado).

En manual funciona de forma continuada (sin atender a la presión de impulsión) y solo se para por la boya de paro o por disparo térmico.

En automático conserva las mismas condiciones que en manual, pero el funcionamiento está condicionado a los presostatos de trabajo; estos deben estar regulados en cascada. En equipos de más de una bomba, se alterna el arranque de las bombas.

Cuadros para bombas de aguas fecales:

Material periférico: Boyas de marcha, paro, sobrenivel y claxon exterior de alarma sobrenivel.

En manual el funcionamiento es continuado y solo se para por la boya de paro o por sobrecarga de la bomba.

En automático conserva las mismas condiciones que en manual, pero la orden de marcha se efectúa por las boyas. En equipos de más de una bomba, se alterna el arranque de las bombas. La boya de alarma nivel acciona un claxon exterior, (bajo demanda se puede instalar en el propio cuadro).



■ CUADROS ELECTRICOS PARA EQUIPOS DE PRESION CON VARIADOR DE FRECUENCIA

■ Tensiones:

400 V trifásico, voltajes especiales (50-60 Hz)

■ Características generales:

Tipo de equipo	Básico: 1 bomba regulada + auxiliares Alternado: rotación de la bomba regulada (bajo demanda)
Armario	Metálico con ventilación forzada
Int. general	En todas las unidades
Indicadores	Piloto verde de bomba en marcha. Piloto rojo de disparo por sobrecarga Piloto amarillo de alarma nivel
Selectores de marcha	Selector de 3 posiciones presostatos - 0 - variador
Protecciones variador	Fusibles rápidos tipo GG/GL
Protecciones bombas aux.	Guardamotor para bombas hasta 15 cv (disyuntor magnetotérmico) Fusibles y relés térmicos para potencias superiores
Accionamiento	Arranque directo con un contactor para bombas inferiores a 7,5 cv. Arranque estrella - triangulo para potencias superiores a 5,5 cv.
Alternancia	Básico: 1 bomba regulada + rotación de todas las auxiliares Alternado: rotación de la bomba regulada (bajo demanda) Rotación total.
Emergencia	Función de emergencia por presostatos de bombas auxiliares en caso de avería del variador
Material auxiliar	Transductor de presión 0-10 / 0-16 bar 4-20 mA

■ Opciones:

Indicadores	Voltímetro general / Amperímetro por bomba / Cuenta horas
Accionamiento	Arranadores suaves en las bombas auxiliares
Protecciones	Diferenciales de alta inmunidad contra disparos intpestivos
Consignas exteriores	Posibilidad de trabajar con varias consignas de presión fijas o variables indicadas por fuentes ext.
Señales externas	Analógicas: presión, consumo bomba regulada, velocidad, etc. Digitales: avería bomba, marcha, etc.
Aplicaciones	Bombas sumergidas / Bombeos de aguas fecales
Armarios	Poliéster IP-65 (para exteriores)

■ Funcionamiento:

Equipos destinados a grupos de presión donde se requiera una presión constante.

Con el sistema de regulación de velocidad el equipo adapta el rendimiento de las bombas al consumo de agua que hay en cada momento.

Principales ventajas:

- Evitamos los constantes arranques y paros de los sistemas convencionales alargando la vida mecánica del equipo.
- Evitamos los golpes de ariete en la instalación gracias a la progresividad de equipo.
- Evitamos tener que instalar grandes acumuladores de membrana o galvanizados.
- La potencia absorbida de la red se adapta al máximo al consumo de agua, minimizando los costes, además la utilizada por el variador es casi totalmente activa.



■ CUADRO DE ARRANQUE Y CONTROL PARA BOMBAS ELÉCTRICAS Y DIESEL SEGÚN UNE 23-500-90.

Construido estrictamente bajo la norma **UNE 23-500-90**. Incorpora panel frontal de policarbonato para fácil comprensión de toda la simbología, dentro del mismo armario encontraremos el arranque, control y protección de la bomba auxiliar o jockey.

Los cuadros están compuestos por armario metálico IP55 color gris Ral 7032, interruptor seccionador general, arrancadores para las bombas, selectores tres posiciones para bomba principal y jockey. Pulsadores de prueba de lámparas y alarmas acústicas. Pulsador de paro de bomba principal. Protección térmica para bomba jockey, voltímetro, amperímetro, contador de arranques jockey, sirena de alarma, batería de soporte. Igualmente, el cuadro de control de bomba diesel, añade sus particularidades, como tacómetro, relojes de temperatura y presión de aceite. En definitiva nuestros cuadros para este tipo de contraincendios incorporan todas las exigencias reflejadas en la normativa **UNE 23-500-90**.

■ CUADRO DE ARRANQUE Y CONTROL PARA BOMBAS ELÉCTRICAS Y DIESEL SEGÚN CEPREVEN RT2 - ABA.

Construido estrictamente bajo las reglas técnicas **CEPREVEN**. Incorpora panel frontal de policarbonato para fácil comprensión de toda la simbología.

Los cuadros están compuestos por armario metálico IP55 color rojo Ral 3000, interruptor seccionador general, arrancadores para las bombas, selectores tres posiciones para bomba principal y jockey. Pulsadores de prueba de lámparas y alarmas acústicas. Pulsador de paro de bomba principal. Protección térmica para bomba jockey, voltímetro, amperímetro, contador de arranques jockey, sirena de alarma, batería de soporte. Igualmente, el cuadro de control de bomba diesel, añade sus particularidades, como 2 cargadores de baterías, prueba de 6 intentos de arranque, pulsador de marcha por batería, amperímetro por batería, tacómetro, relojes de temperatura y presión de aceite. En definitiva nuestros cuadros para este tipo de contraincendios incorporan todas las exigencias reflejadas en la regla técnica **CEPREVEN RT2 - ABA**.

■ CUADRO DE ARRANQUE Y CONTROL PARA OTRO TIPO DE REGLAMENTACIONES

Igualmente indicar que nuestro departamento técnico, le asesorará o le podrá estudiar cualquier otro montaje para cumplir con las normativa **UNE 23-500-98**, o con la reciente normativa de aplicación general **UNE - EN 12845**.



■ CUADROS ELECTRICOS PARA BOMBAS DE PISCINAS

■ Tensiones:

230 V monofásico (hasta 3 CV), 230 V trifásico (hasta 5,5 CV), 400 V trifásico, voltajes especiales (50-60 Hz)

■ Características generales:

Armario	Cajas de material plástico IP-55
Selector de marcha	Selector de 2 posiciones MANUAL - AUTOMÁTICO
Protecciones	Guardamotor bomba (disyuntor magnetotérmico)
Accionamiento	Minicontactor
Protección focos	Magnetotérmico 2 polos 10 A
Programador	Electromecánico, diario, regulación mínima 15 min.
Transformadores	Transformador de seguridad apantallado 350 VA. Cumple UNE-20.339/EN-61558/MIBT028/MIBT035

■ Opciones:

Diferencial	2 polos 40 A 30 ma para bombas monofásicas 4 polos 40 A 30 ma para bombas trifásicas
Magnetotérmico general	1 polo + neutro de 6/10/16 A para bombas monofásicas 3 polos + neutro de 7,5/10/15 A para bombas trifásicas
Control remoto	Para encendido de focos a distancia
Programador	Electromecánico con reserva de cuerda 160 h. Digital semanal con reserva de cuerda prog. mínima 1 min.

■ Funcionamiento:

Equipos destinados a la filtración de piscinas con una sola bomba monofásicas hasta 3 cv y trifásicas hasta 5,5 cv. La orden de filtración puede ser manual o automática a traves del reloj programador. Pueden incorporar 1, 2 o 3 transformadores de 230/12 voltios para focos de 300 vatios. El encendido de estos es manual, pero bajo demanda se pueden incorporar sistemas con mando a distancia, o programadores automáticos.

■ CUADROS ELECTRICOS PARA BOMBAS SUMERGIBLES DE POZO

■ Tensiones:

230 V monofásico (hasta 2 CV), 400 V trifásico (hasta 5,5 CV)

■ Características generales:

Armario	Cajas de material plástico IP-54
Selector de marcha	Selector de 3 posiciones MAN. - 0 - AUT.
Protecciones	Magnetotérmico y relé térmico
Accionamiento	Contactador para arranque directo
Indicadores	Piloto verde de bomba en marcha Piloto rojo de disparo por sobrecarga
Control de nivel	Relé de control de sondas de pozo
Sondas	Incorpora 3 sondas colgantes



■ Funcionamiento:

Equipos destinados al control de bombas sumergidas monofásicas hasta 3 cv, trifásicas y voltajes especiales (50-60 Hz). Incorpora un selector de tres posiciones MAN - PARO - AUTOMÁTICO. En posición manual el funcionamiento es continuado y la bomba solo está protegida de sobrecargas, en automático la orden de marcha puede ser exterior (prestatato) o por el controlador de nivel.

<u>Conexiones Motores Eléctricos</u>	<u>196</u>
<u>Datos Técnicos Bombas Sumergibles</u>	<u>197</u>
<u>Tablas de Selección de Sección de Cable</u>	<u>198</u>
<u>Pérdidas de Carga en las Tuberías</u>	<u>200</u>

MONOFÁSICO

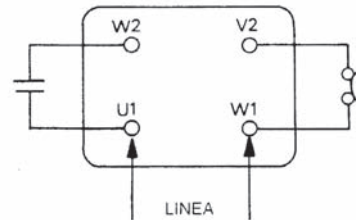
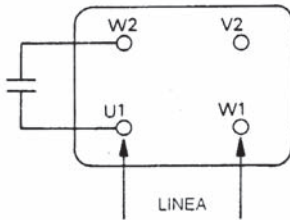
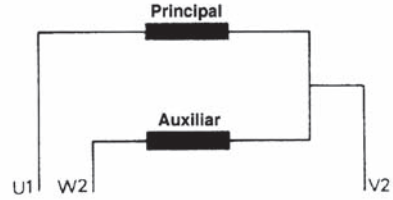
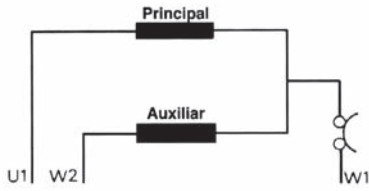

Motoprotector en el bobinado

Motoprotector en los bornes

TRIFÁSICO

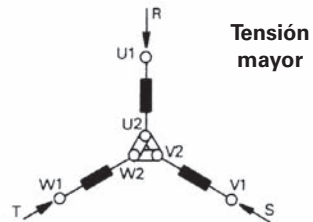
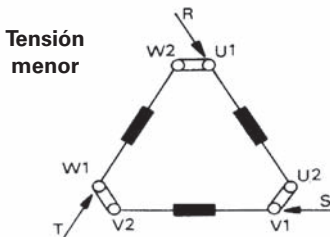

Conexión Triángulo

Conexión Estrella

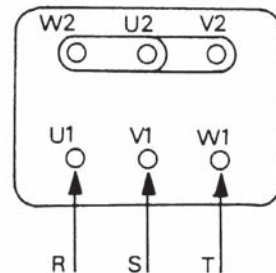
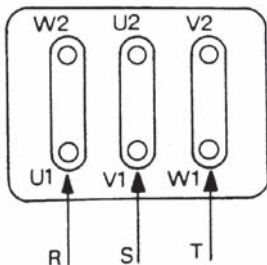

Sentido de la agujas del reloj, mirado desde el lado ventilador

TABLAS DE SECCIÓN DE CABLE SEGÚN SU LONGITUD Y POTENCIA DEL MOTOR
MOTORES MONOFÁSICOS 220V

Potencia		Sección cable mm ²					
		1,5	2,5	4	6	10	16
CV	KW	Longitud cable en metros					
		0,33	0,25	170	280	450	670
0,50	0,37	120	200	320	480	810	1260
0,75	0,55	80	130	220	320	550	850
1	0,75	60	100	170	250	430	670
1,5	1,1	40	70	120	180	300	470
2	1,5	30	60	90	130	230	360
3	2,2	20	40	60	90	150	230

TABLA DE POTENCIAS PARA GENERADORES

Potencia motor monofásico y trifásico en:		Potencia mínima del generador en:	
HP	KW	KW	KWA
0,5	0,37	1,5	2
0,75	0,55	2	2,5
1	0,75	2,5	3
1,5	1,1	3,5	4,5
2	1,5	4	5
3	2,2	6	7,5
4	3	9	11
5,5	4	10	12,5
7,5	5,5	12,5	15,6
10	7,5	15	18
12,5	9,2	18,8	23,5
15	11	22,5	28
20	15	30	38
25	18,5	40	50
30	22	45	57
40	30	60	75
50	37	75	94
60	45	90	112
70	51	105	131
100	75	150	190
125	92	185	230
150	110	210	260

ESQUEMA DE CONEXIÓN MOTORES MONOFÁSICOS

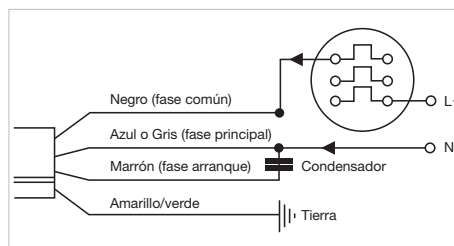

Para cerrar con estanqueidad la conexión de la prolongación del cable, téngase en cuenta el EMPALME RETRÁCTIL

**TABLAS DE SECCIÓN DE CABLE SEGÚN SU LONGITUD Y POTENCIA DEL MOTOR
MOTORES TRIFÁSICOS - ARRANQUE DIRECTO**

Arranque Directo														
Potencia		Tensión	Sección del cable en mm ²											
			1,5	2,5	4	6	10	16	25	35	50	70	95	
HP	KW		Longitud máxima en metros											
0,5	0,37	230V	176	293										
		400V	524											
0,75	0,55	230V	141	235	377									
		400V	422											
1	0,75	230V	110	183	293									
		400V	328	547										
1,5	1,1	230V	70	117	187	280								
		400V	209	349	558									
2	1,5	230V	53	89	143	214								
		400V	150	266	427									
3	2,2	230V	38	63	101	151								
		400V	113	188	302	452								
4	3	230V	30	50	81	121	200							
		400V	90	151	241	362								
5,5	4	230V	22	37	60	90	150	240						
		400V	67	110	179	269	450							
7,5	5,5	230V		28	45	67	111	180	275					
		400V	50	85	135	195	340	540						
10	7,5	230V		21	34	50	85	135	210					
		400V		64	100	150	255	410						
12,5	9,2	230V		27	41	68	109	155	230					
		400V		50	81	122	205	325	496					
15	11	230V				35	59	93	142	200	230			
		400V			70	105	177	280	430					
17,5	13	230V					51	79	125	172	240			
		400V				90	153	240	375	515				
20	15	230V					44	70	107	148	205			
		400V				78	131	210	320	445				
25	18,5	230V						56	87	120	167	230		
		400V					105	170	261	360	500			
30	22	230V							71	98	136	186		
		400V					89	139	212	294	409			
35	26	230V							64	88	123	168	213	
		400V						122	191	264	369	504		
40	30	230V							56	78	109	150	189	
		400V						108	170	235	327	448		
50	37	230V								64	89	123	156	
		400V							138	190	268	368	468	
60	45	230V									76	105	133	
		400V								115	160	228	314	398
70	51	230V										92	116	
		400V									140	200	275	349
75	55	230V										80	103	
		400V									120	175	240	308
90	66	230V											93	
		400V										155	220	278
100	75	230V												195
		400V												248
125	92	230V												
		400V												202
150	110	230V												
		400V												166

**TABLAS DE SECCIÓN DE CABLE SEGÚN SU LONGITUD Y POTENCIA DEL MOTOR
MOTORES TRIFÁSICOS - ARRANQUE ESTRELLA-TRIÁNGULO**

Arranque Estrella-triángulo													
Potencia		Tensión	2 cables de sección mm ²										
HP	KW		1,5	2,5	4	6	10	16	25	35	50	70	95
Longitud máxima en metros													
4	3	230V	46	75	122	180							
		400V	136	225	365								
5,5	4	230V	34	56	91	136	235						
		400V	102	168	270	405							
7,5	5,5	230V	25	42	67	100	175						
		400V	76	128	200	300	510						
10	7,5	230V	19	31	50	75	129	203					
		400V	57	93	150	225	385						
12,5	9,2	230V		25	40	60	103	161					
		400V	45	75	120	180	309	483					
15	11	230V		22	35	52	90	141	215				
		400V	39	66	105	156	270	421					
17,5	13	230V		19	30	45	77	121	185				
		400V		57	90	135	230	360					
20	15	230V			26	39	57	104	159	219			
		400V		48	77	116	200	310	475				
25	18,5	230V				31	54	84	128	177			
		400V			63	93	161	251	383	530			
30	22	230V				43	68	103	143	199			
		400V			51	76	129	203	309	428			
35	26	230V				39	61	93	128	179			
		400V			45	68	117	183	279	384			
40	30	230V					54	83	115	159	217		
		400V				60	104	162	248	343	476		
50	37	230V					44	68	94	131	179		
		400V				50	86	132	204	281	392		
60	45	230V						58	80	111	152	192	
		400V					73	112	173	239	332	454	
70	51	230V						51	70	98	133	169	
		400V						99	152	210	292	395	505
75	55	230V							62	86	117	149	
		400V						87	133	185	257	350	445
90	66	230V							56	78	106	135	
		400V						120	167	233	317	403	
100	75	230V								70	95	120	
		400V							108	149	209	284	359
125	92	400V							121	169	230	293	
150	110	400V								140	190	242	



Bombas Saci, S.A.

Crta. de Mataró, km. 629
Pol. Ind. Ribó, 08911 Badalona
(Barcelona) Spain

TEL. [+34] 933 842 351
FAX. [+34] 933 842 900

saci@bombas-saci.com
www.sacipumps.com

N 41° 27.446
E 2° 15.733

Delegación:

Pol.Ind. Pocomaco
Parcela D-31
15190 A Coruña Spain

TEL. [+34] 981 299 688
FAX. [+34] 981 299 616

sacicoruna@bombas-saci.com
www.sacipumps.com

N 43° 19.598
W 8° 26.389



GC-15